

## **Closure Completion Notification for Closure by Removal**

January 15, 2025

Closure Completion Notification

Flint Creek Plant

Primary Bottom Ash Pond

On December 24, 2024, the Flint Creek Plant Primary Bottom Ash Pond was transitioned to closure status in accordance with 40 CFR 257.102. This notice of completion of closure is being placed in the operating record in accordance with 40 CFR 257.102(h).

Effective with the Closure Completion Notification, the former ash storage site is no longer a CCR unit. The following operating record documents are no longer required going forward:

- Hazard Potential Classification
- Emergency Action Plan (EAP)
- Face to Face Meeting Documentation for EAP
- History of Construction and Revisions for Surface Impoundments
- Structural Stability Assessments
- Safety Factor Assessments
- Fugitive Dust Plan
- Inflow Design Flood System Control Plan

**CLOSURE CERTIFICATION BY QUALIFIED PROFESSIONAL ENGINEER**

I certify that the AEP Flint Creek Primary Bottom Ash Pond has been closed in accordance with the most recent written closure plan specified by 40 CFR 257.102(b) and the requirements of 40 CFR 257.102.

**David Anthony Miller**

Printed Name of Licensed Professional Engineer

*David Anthony Miller*

Signature



**15296**

License Number

**Arkansas**

Licensing State

**01.15.2025**

Date

## 4.0 PROFESSIONAL ENGINEER CERTIFICATION

This Closure By Removal Certification and Construction Summary Report confirms that the construction activities associated with the closure of the PBAP (refer to Section 3.0) were performed in accordance with the requirements contained in the Closure Plan; and therefore, meet the closure criteria defined in 40 CFR §257.102.

The following certification statement provides confirmation that this report was prepared by a qualified professional engineer registered in the state of Arkansas and that there is sufficient information to demonstrate that the closure of the PBAP meets the requirements of the Closure Plan and 40 CFR §257.102.

### Professional Engineer's Certification

---

*Based on the work completed, the visual observation of the pond bottom by CEC field personnel during CCR removal, and review of the final topographic survey, I certify that the CCR contained in the Flint Creek Primary Bottom Ash Pond has been removed in general accordance with the Closure Plan prepared by American Electric Power dated September 2016, revised October 2023.*

**Jeff A Shepherd, P.E.**

---

**Printed Name of Professional Engineer**

  
Signature

**10836**

**Arkansas**

**01-30-2024**

---

**Registration No.**

**Registration State**

**Date**



# HISTORY OF CONSTRUCTION

**CFR 257.73(c)(1)**

Primary Ash Pond

Flint Creek Plant  
Gentry, Arkansas

September, 2016

Prepared for: Southwestern Electric Power Company

Prepared by: American Electric Power Service Corporation

1 Riverside Plaza

Columbus, OH 43215



**GERS-16-026**

## Table of CONTENTS

<b>1.0 OBJECTIVE</b> .....	3
<b>2.0 DESCRIPTION OF CCR THE IMPOUNDMENT</b> .....	3
<b>3.0 SUMMARY OF OWNERSHIP 257.73(c)(1)(i)</b> .....	3
<b>4.0 LOCATION OF THE CCR UNIT 257.73 (c)(1)(ii)</b> .....	3
<b>5.0 STATEMENT OF PURPOSE 257.73 (c)(1)(iii)</b> .....	3
<b>6.0 NAME AND SIZE OF WATERSHED THE CCR UNIT IS LOCATED</b> <b>257.73 (c)(1)(iv)</b>	3
<b>7.0 DESCRIPTION OF THE FOUNDATION AND ABUTMENT MATERIALS 257.73(c)(1)(v)</b> .....	4
<b>8.0 DESCRIPTION OF EACH CONSTRUCTED ZONE OR STAGE OF THE CCR UNIT 257.73 (c)(1)(vi)</b> .....	4
<b>9.0 ENGINEERING STRUCTURES AND APPURTENANCES, 257.73 (c)(1)(vii)</b> .....	4
<b>10.0 SUMMARY OF POOL SURFACE ELEVATIONS, AND MAXIMUM DEPTH OF CCR, 257.73 (c)(1)(vii)</b> .....	5
<b>11.0 FEATURES THAT COULD ADVERSELY AFFECT OPERATION DUE TO MALFUNCTION OR MIS-OPERATION (257.73 (c)(1)(vii))</b> .....	5
<b>12.0 DESCRIPTION OF THE TYPE, PURPOSE AND LOCATION OF EXISTING INSTRUMENTATION 257.73 (c)(1)(viii)</b> .....	5
<b>13.0 AREA – CAPACITY CURVES FOR THE CCR UNIT 257.73 (c)(1)(ix)</b> .....	6
<b>14.0 257.73 (c)(1)(x) DESCRIPTION OF EACH SPILLWAY AND DIVERSION</b> .....	6
<b>15.0 SUMMARY CONSTRUCTION SPECIFICATIONS AND PROVISIONS FOR SURVEILLANCE, MAINTENANCE AND REPAIR 257.73 (c)(1)(xi)</b> .....	6
<b>16.0 RECORD OR KNOWLEDGE OF STRUCTURAL INSTABILITY 257.73 (c)(1)(xii)</b> .....	7

### **Attachments**

- Attachment A – Location Map
- Attachment B – Construction Design Specification
- Attachment C – Design Drawings
- Attachment D – Instrumentation Location Map
- Attachment E – Construction Specifications

## **1.0 OBJECTIVE**

This report was prepared by AEP- Geotechnical Engineering Services (GES) section to fulfill requirements of CCR 257.73(c)(1) with an evaluation of the facility.

## **2.0 DESCRIPTION OF CCR THE IMPOUNDMENT**

The Flint Creek Power Plant is located near the City of Gentry, Benton County, Arkansas. It is owned and operated by Southwestern Electric Power Company (SWEPCO). The facility operates one surface impoundment for storing CCR called the Primary Ash Pond.

The Primary Ash Pond dam is a cross valley dam on a tributary to the Little Flint Creek. The dam is 45 feet high and has side slopes of 3H:1V. The downstream slope is partially submerged by the Little Flint Creek Reservoir.

## **3.0 SUMMARY OF OWNERSHIP 257.73(c)(1)(i)**

*[The name and address of the person(s) owning or operating the CCR unit: the name associated with the CCR unit: and the identification number of the CCR unit if one has been assigned by the state.]*

The Primary Ash Pond at the Flint Creek Power Plant is located at 21797 SWEPCO Plant Road, Gentry, Arkansas. It is owned and operated by SWEPCo.

## **4.0 LOCATION OF THE CCR UNIT 257.73 (c)(1)(ii)**

*[The location of the CCR unit identified on the most recent U.S. Geological Survey (USGS) 7 ½ minute or 15 minute topographic quadrangle map, or a topographic map of equivalent scale if a USGS map is not available.]*

A location map is included in Attachment A.

## **5.0 STATEMENT OF PURPOSE 257.73 (c)(1)(iii)**

*[A statement of the purpose for which the CCR unit is being used.]*

The Primary Ash Pond is a surface impoundment for settling and storage of bottom ash and other minimal amounts of CCRs.

## **6.0 NAME AND SIZE OF WATERSHED THE CCR UNIT IS LOCATED**

### **257.73 (c)(1)(iv)**

*[The name and size in acres of the watershed within which the CCR unit is located.]*

The Primary Ash Pond is located in the Illinois Watershed (HUC 11110103) which is 1,053,683 acres (1646.38 square miles). The watershed to the Primary Ash Pond is approximately 1167 acres consisting of primarily agricultural land, the plant site and residential parts of Gentry, Arkansas. This ash pond is on a no-name tributary to Little Flint Creek.

## **7.0 DESCRIPTION OF THE FOUNDATION AND ABUTMENT MATERIALS**

### **257.73(c)(1)(v)**

*[A description of the physical and engineering properties of the foundation and abutment materials on which the CCR unit is located.]*

The dam was constructed on a limestone foundation. The soils on the abutments consist of stiff clays with gravel, which are the residual soils from the limestone unit. A subsurface investigation was conducted in 2009 and the strength parameters of the foundation as well as the embankment were defined based on laboratory tests or correlations to known strengths based on blow counts.

The geotechnical reports in Attachment B provide the specific properties of the foundation materials.

## **8.0 DESCRIPTION OF EACH CONSTRUCTED ZONE OR STAGE OF THE CCR UNIT**

### **257.73 (c)(1)(vi)**

*[A statement of the type, size, range, and physical and engineering properties of the materials used in constructing each zone or stage of the CCR unit; and the approximate dates of construction of each successive stage of construction of the CCR unit.]*

The Primary Ash Pond dam was constructed as a homogenous dam. The material was the native clays soils and the specifications stated that each lift be compacted to 90% Modified proctor dry density. Construction was started in 1974 and completed in 1978.

The geotechnical reports in Attachment B provide the specific properties of the foundation materials.

## **9.0 ENGINEERING STRUCTURES AND APPURTENANCES, 257.73 (c)(1)(vii)**

*[At a scale that details engineering structures and appurtenances relevant to the design, construction, operation, and maintenance of the CCR unit, detailed dimensional drawings of the CCR unit, including a plan view and cross sections of the length and width of the CCR unit, showing all zones, foundation improvements, drainage provisions, spillways, diversion ditches, outlets, instrument locations, and slope protection...]*

The primary spillway is a weir box connected to a 36-inch diameter pipe which regulates normal flow conditions. There is also a wide open channel controlled by a concrete sill for larger events. Both of the structures discharge into the secondary pond.

The engineering drawings of the engineering structures and appurtenances are included in Attachment C.

As described previously, the Primary Ash Pond is a cross valley dam so there are no diversion ditches.

Slope protection along the inboard and outboard slope consists primarily grass vegetation and portions

of the lower downstream slope is riprap for protection from the wave action and pool fluctuations of the Little Flint Creek reservoir.

**10.0 SUMMARY OF POOL SURFACE ELEVATIONS, AND MAXIMUM DEPTH OF CCR, 257.73 (c)(1)(vii)**

*[...in addition to the normal operating pool surface elevation and the maximum pool elevation following peak discharge from the inflow design flood, the expected maximum depth of CCR within the CCR surface impoundment.]*

The table below describes the normal pool elevations and maximum pool elevations as well as maximum depth of CCR within the impoundment.

	<b>Primary Ash Pond</b>
Dam Crest Elevation	1155
Normal Pool Elevation	1144-1146
Maximum Pool Elevation following peak discharge from inflow design flood	1151.96
Expected Maximum depth of CCR within impoundment	36 feet

**11.0 FEATURES THAT COULD ADVERSELY AFFECT OPERATION DUE TO MALFUNCTION OR MIS-OPERATION (257.73 (c)(1)(vii))**

*[...and any identifiable natural or manmade features that could adversely affect operations of the CCR runit due to malfunction or mis-operation]*

During an extreme flood event, natural debris may tend to collect along the open channel spillway. The spillway is wide and complete blockage would not be an expected condition.

**12.0 DESCRIPTION OF THE TYPE, PURPOSE AND LOCATION OF EXISTING INSTRUMENTATION 257.73 (c)(1)(viii)**

*[A description of the type, purpose, and location of existing instrumentation.]*

The Primary Ash Pond has 4 piezometers located within the structure of the dam. These piezometers are read on a minimum of every 30 days for the purpose of determining the phreatic water level within the dike. An instrumentation location map is provided in Attachment D.



### **13.0 AREA – CAPACITY CURVES FOR THE CCR UNIT 257.73 (c)(1)(ix)**

*[Area-capacity curves for the CCR unit.]*

The area capacity curves for the Primary Ash Pond are included in the Hydraulic Analysis Report by Freese and Nichols, January 2011 in the Inflow Design Flood Control Plan.

### **14.0 257.73 (c)(1)(x) DESCRIPTION OF EACH SPILLWAY AND DIVERSION**

*[A description of each spillway and diversion design features and capacities and calculations used in their determination.]*

The principal spillway for the Primary Ash Pond consists of a weir box with a 4-foot wide weir with crest elevation of 1144.0 ft-msl. The weir equation used for this weir box was provided by AEP personnel. At elevation 1146.0 ft-msl, flow reaches the 228-foot long concrete sill, effectively the emergency spillway, and the weir box is assumed to be submerged, meaning flow is completely controlled by the emergency spillway. The sill is located relatively close to the flat natural grade and is currently covered with soil and light vegetation due to silting over the years. As such, the emergency spillway is modeled as a broad-crested weir, and the discharge rating curve was developed with a steady-state HEC-RAS<sup>4</sup> model. The HEC-RAS model accounts for submergence of the tailwater from the downstream lake, which will significantly restrict flow through the spillway. The discharge rating curve for the combined spillway of the Primary Ash Pond is shown in Table 4. A photograph of the spillway is shown in Figure 5.

Complete details of each spillway structure are included with the design drawings in Attachment C. Hydrology and Hydraulic Analysis which include calculations for each spillway structure are included in Inflow Design Flood Control Plan.

### **15.0 SUMMARY CONSTRUCTION SPECIFICATIONS AND PROVISIONS FOR SURVEILLANCE, MAINTENANCE AND REPAIR 257.73 (c)(1)(xi)**

*[The construction specifications and provisions for surveillance, maintenance, and repair of the CCR unit.]*

Readily available portions of the original construction specifications are included in Appendix E.

As required by the CCR rules the Primary Ash Pond is inspected at least every 7 days by a qualified person. Instrumentation data is collected at least every 30 days and reviewed by AEP Engineering Services. Also as a requirement of the CCR rules the impoundment is also inspected annual by a professional engineer.

If repairs are found to be necessary during any inspection they will be completed as needed.

**16.0 RECORD OR KNOWLEDGE OF STRUCTURAL INSTABILITY 257.73 (c)(1)(xii)**  
*[Any record or knowledge of the structural instability of the CCR unit.]*

To date there has been know record of knowledge of the structural instability of the CCR unit.

**ATTACHMENT A**

**LOCATION MAP**

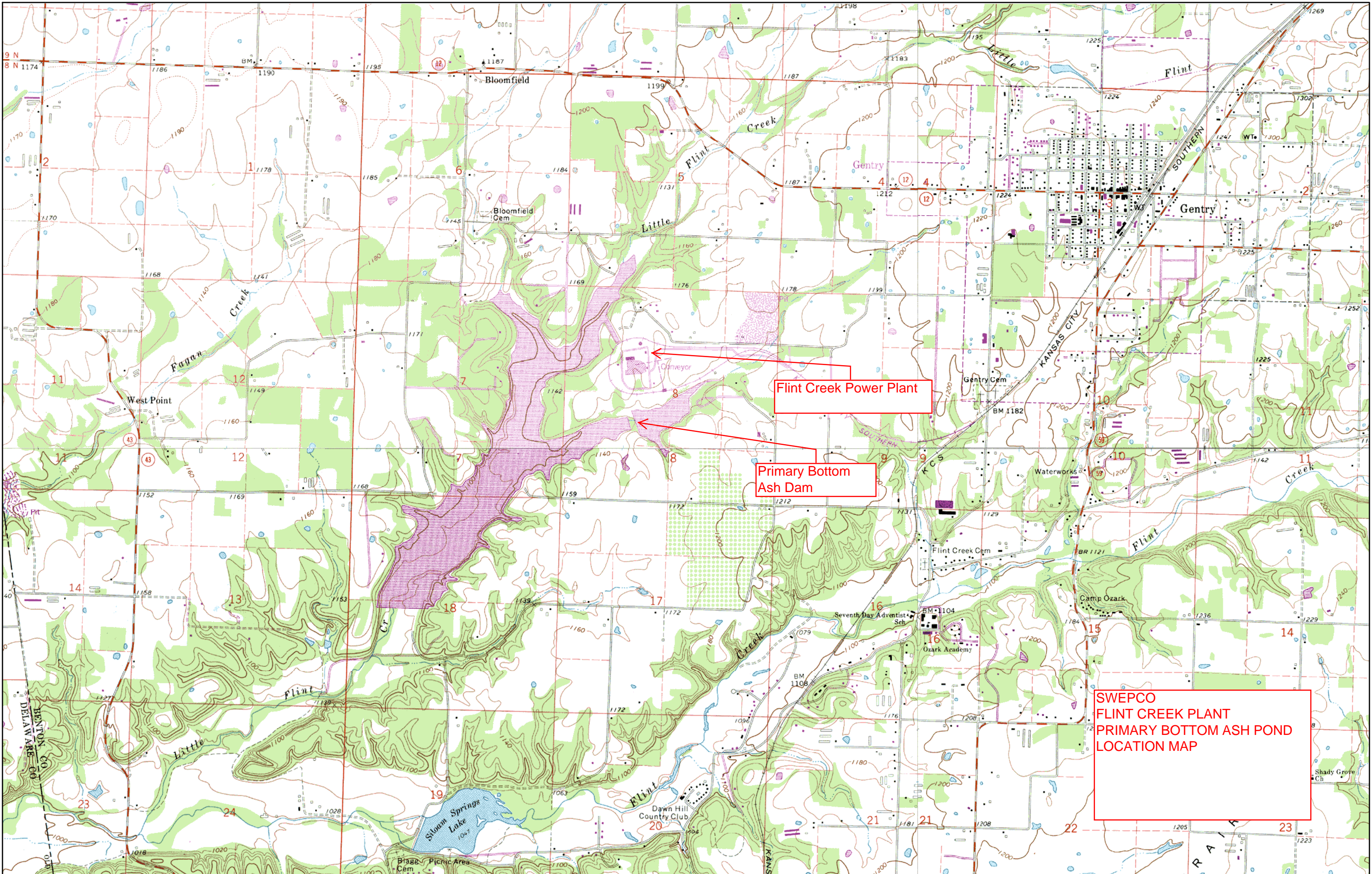

Flint Creek Power Plant

Primary Bottom Ash Dam

SWEPCO  
FLINT CREEK PLANT  
PRIMARY BOTTOM ASH POND  
LOCATION MAP

**ATTACHMENT B**

**DESIGN REPORTS**



# ETTL Engineers & Consultants Inc.

GEOTECHNICAL \* MATERIALS \* ENVIRONMENTAL \* DRILLING \* LANDFILLS

August 18, 2010

W. Greg Carter, P.E.  
American Electric Power  
21797 SWEPCO Plant Road  
Gentry, AR 72734

SUBJECT: Flint Creek Power Station, Existing Ash Storage Ponds Embankment  
Investigation, Pittsburg, Texas  
Geotechnical Investigation  
ETTL Job No. G3243-09

Dear Mr. Carter:

Submitted herein is the report summarizing the results of a geotechnical investigation conducted at the site of the above referenced project.

If you have any questions concerning this report, please contact us. We are also available to perform any construction materials testing and inspection services that you may require.

Thank you for the opportunity to be of service.

Sincerely,  
ETTL Engineers & Consultants Inc.

Robert M. Duke  
Senior Project Manager

Stephen R. Richards, P.E.  
Principal Consultant



August 18, 2010

Distribution: (2) AEP

210 Beech Street  
Texarkana, AR 71854  
870-772-0013 Phone  
870-216-2413 Fax

1717 East Erwin  
Tyler, Texas 75702  
903-595-4421 Phone  
903-595-6113 Fax

707 West Cotton Street  
Longview, Texas 75604-5505  
903-758-0915 Phone  
903-758-8245 Fax

**Geotechnical Investigation  
Flint Creek Power Station  
Existing Ash Storage Ponds Embankment Investigation  
Gentry, Arkansas**

Submitted to

American Electric Power  
Gentry, Arkansas

Prepared by

ETTL Engineers & Consultants Inc.  
Tyler, Texas

(Revision 2)  
August 2010

## EXECUTIVE SUMMARY

This Executive Summary is provided as a brief synopsis of the specific recommendations and design criteria provided in the attached report. It is not intended as a substitute for a thorough reading of the report in its entirety.

### Project Description

Evaluation of the existing earthen embankments for the ash ponds at the Flint Creek Power Station. Slope stability and seepage analyses for the embankments were performed using information obtained from soil borings located on the crest and downstream toe of the embankments. The embankments for the Primary and Secondary Bottom Ash Ponds were investigated.

### Site Description

This investigation was conducted on the Flint Creek Power Station embankments that are located at the plant which is located at 21797 SWEPCO Plant Road. The power plant is located on the northeast side of the Reservoir and the ash ponds are located to the south of the plant on the east side of the reservoir.

### Depth & Number of Borings

Three borings were drilled to 30 feet deep at the native soil level and four borings were drilled to 50 feet deep in the crests of the embankments. The four deep borings were converted to piezometers.

### Soils Encountered

The fill material in the containment berm consists primarily of stiff to very stiff lean clay (CL) or fat clay (CH) with gravel and medium dense clayey gravel (GC) or clayey sand (SC) with gravel overlying native soils which consist primarily of weathered limestone with layers of stiff to hard lean clay (CL) with gravel. The limestone encountered typically consisted of solid layers less than 14 inches thick. The Rock Quality Designation (RQD) of the cores is less than 25%. Atterberg Plasticity Indices of the tested soils ranged from 5 to 47.

### Groundwater Depth

Found to range from elevation 1119 to 1135 msl in the open boreholes. Groundwater is anticipated to be between the lake elevation of 1140 and the primary and secondary pond elevations of 1146 and 1143 respectively.

### Embankment Stability

The existing berm slopes are acceptable ***if conditions are maintained***. A minimum factor of safety of 1.6 in the long term was found on the Secondary Ash Pond. Rapid drawdown of the level of water in the individual ponds lowers the predicted overall stability factors of safety to a minimum of 1.2 at the Primary Ash Pond (assuming no ash in the pond left against the slope).





## TABLE OF CONTENTS

EXECUTIVE SUMMARY .....	1
1.0 INTRODUCTION .....	1
2.0 PROJECT DESCRIPTION .....	1
3.0 SITE DESCRIPTION .....	2
4.0 FOUNDATION STRATIGRAPHY & PROPERTIES.....	2
4.1 SURFACE WATER CHARACTERISTICS.....	2
4.2 REGIONAL GEOLOGY .....	2
4.2.1 <i>Stratigraphy and Structure</i> .....	2
4.2.2 <i>Boone Formation</i> .....	2
4.2 GEOLOGIC PROCESSES .....	3
4.2.1 <i>Fault Systems and Structural Processes</i> .....	3
4.2.1.1 Seismic Design Parameters .....	3
4.2.1.2 Liquefaction.....	3
4.2.2 <i>Erosional Processes</i> .....	4
4.3 SOIL STRATIGRAPHY.....	4
5.0 GROUNDWATER OBSERVATIONS.....	4
5.1 PIEZOMETERS.....	4
5.2 EMBANKMENT SEEPAGE STUDIES .....	5
5.2.1 <i>Seepage Losses and Pressures</i> .....	5
6.0 POND EMBANKMENT SECTIONS .....	6
6.1 SLOPE STABILITY ANALYSIS .....	6
6.2 SLOPE PROTECTION .....	8
7.0 EMBANKMENT MONITORING .....	8
8.0 LIMITATIONS .....	8
APPENDIX .....	10
I.0 FIELD OPERATIONS .....	10
II.0 LABORATORY TESTING.....	10

Plate I: Plan of Borings  
 Plate 2: Site Surface Geology  
 Logs of Borings with Laboratory Test Data  
 Seepage Results  
 Slope Stability Results  
 Test Results  
 Arkansas Water Well Reports  
 Key to Soil Classification & Symbols



## 1.0 INTRODUCTION

This study was performed at the request and authorization to proceed granted by Greg Carter, P.E. with AEP, Hallsville, Texas in accordance with our proposal dated October 13, 2009. Field operations were conducted on November 3<sup>rd</sup> through November 6<sup>th</sup>, 2009.

The purpose of this investigation was to define and evaluate the general subsurface conditions for the primary and secondary ash ponds at the Flint Creek Power Plant in Gentry, Arkansas. Specifically, the study was planned to determine the following:

- Subsurface stratigraphy within the limits of exploratory borings;
- Classification, strength, and permeability characteristics of the embankment and foundation soils; and
- Slope stability and seepage of the existing embankments;

To determine this information a variety of tests were performed on the soil and ash samples. The scope of testing for this report comprised Standard Penetration, Atterberg liquid and plastic limits, Percentage of Fines Passing the No. 200 sieve and Natural Moisture Content, Unconsolidated Undrained Triaxial tests, and Permeability. These tests were conducted to classify the soil strata according to a widely used engineering classification system; identify, and provide quantitative data for soils; define shear strength characteristics; define seepage characteristics; and determine the slope stability of the existing embankments.

The conclusions and recommendations that follow are based on limited information regarding site topography provided to E TTL by others. *Should any portion of this information prove incorrect, this firm should be notified in order to assess the need for revisions to this report.* Borings were drilled at locations based on a site plan provided by the client.

## 2.0 PROJECT DESCRIPTION

This project entails the evaluation of the existing earthen embankments at the Flint Creek Power Station. Slope stability and seepage analyses for the embankments was performed using information obtained from soil borings located on the crest and outside toe of the embankments. The embankments for the Primary and Secondary ash ponds were evaluated:

One seepage and one stability analyses was conducted for each pond. Table 2.0 below, lists the number of borings and depths for each pond as well as the piezometers installed.

<b>Pond</b>	<b>Boring Numbers &amp; Depths</b>	<b>Piezometer Numbers and Depths</b>
Primary Ash Pond	B-3 – 37 feet deep B-4 – 50 feet deep B-5 – 30 feet deep	B-3 – 37 feet deep B-4 – 50 feet deep
Secondary Ash Pond	B-1 – 48 feet deep B-2 – 50 feet deep B-6 – 23 feet deep B-7 – 11 feet deep	B-1 – 48 feet deep B-2 – 50 feet deep



### **3.0 SITE DESCRIPTION**

This investigation was conducted on the Flint Creek Power Station embankments that are located throughout the plant which is located at 21797 SWEPCO Plant Road. The Ash ponds are located south of the plant and east of the reservoir. See the Plans of Borings for the locations of the embankments investigated.

### **4.0 FOUNDATION STRATIGRAPHY & PROPERTIES**

Regional, local, and site-specific environmental characteristics have been identified by review of the surface, subsurface, and groundwater data gathered during the course of this study.

#### **4.1 Surface Water Characteristics**

The site is situated on a topographically level feature, with a slight slope from northeast to southwest. The surface elevation of the study site is 1100 to 1160 feet above mean sea level (msl). Little Flint Creek enters the subject site along the western portion of the property and flows into the reservoir. The ash ponds are located on an unnamed tributary that flows along the south side of the property into the reservoir. Surface water runoff from the site is expected to move to the southwest along Little Flint Creek.

#### **4.2 Regional Geology**

##### **4.2.1 Stratigraphy and Structure**

The State of Arkansas can be divided geologically into two general areas of nearly equal size. The northwestern half is part of a physiographic division that is known as the Interior Highlands, and the southeastern half is part of the Gulf Coastal Plain. The rocks in the highland area are dominated by well-lithified sandstones, shales, limestones, and dolostones of Paleozoic age. The rocks of the Ozarks tilt slightly to the south and have a dendritic drainage pattern. Since shales and siltstones erode faster than sandstones and limestones, the basic topography is flat-topped mountains with stepped flanks. By contrast, the topographic expression of the Ouachitas to the south is controlled not only by the erosional resistance of the rocks, but also by their internal structure. The strata are complexly folded and frequently faulted. The mountains are mostly east-west-trending ridges supported by erosionally resistant rocks and separated by less resistant rocks.

##### **4.2.2 Boone Formation**

The Boone Formation outcrops at the study site. The Boone Formation is predominately lower Mississippian in age. The overlying soils are of the Bodine Series, which vary in thickness from 10 feet to 50 feet. These soils were developed in residuum from very cherty limestones on strong to steep slopes. The soils are coarser textured and more yellow than the Baxter soils, also more cherty. In general they may be described as brown to reddish-brown to brownish-yellow clay, silty and very cherty. The high content of chert is a major factor of the soils and tends to obscure other morphology.

The Boone Formation is described as a cherty limestone, consisting of beds of chert and thin to massively bedded limestone, which vary in character in lateral extent. The Boone can be distinguished by presence of chert, which is seen in the exposures or in the subsurface cores. The Chert beds cover most of the slopes and valley floors.

When first exposed the chert is compact and a light gray color. On weathering it may become yellowish brown from iron staining, fragmental, light and porous, also many diverse colors. It may occur as concretions in limestone beds, as lenses and as massive beds. The Boone has considerable silica in these beds and upon removal of the lime by solution the remaining rock has a porous texture. This is also referred to as "Cripoli". Some of the limestone beds are charged with



bituminous matter, which gives off an odor when broken and exhibit a dark residue appearing as dried asphalt.

Solution waters create some caves and voids throughout the Boone and it is not uncommon to penetrate a void while drilling this formation.

In this area of Little Flint Creek the thickness of Boone could be as much as 350 feet. It is believed that none of the borings in this investigation penetrated any formation older than the Boone.

## 4.2 Geologic Processes

### 4.2.1 Fault Systems and Structural Processes

The project site was examined for the presence of faulting by reviewing available literature, maps, and site reconnaissance, in addition to the examination of the subsurface boring data for the site.

There are minor faults running northeast and southwest approximately two to five miles in either direction of this site. Structures that formed on the flank of the Ozark dome of the late Paleozoic Ouachita orogeny are identified as monoclinical folds that displace the generally flat lying Boone Formation. Both east-striking normal faults and broader northeast-striking dextral strike-slip fault zones probably reflect Pennsylvanian-Early Permian deformation of the developing Ouachita orogeny. The caves and voids throughout the Boone mentioned above can also produce localized sinkholes.

#### 4.2.1.1 Seismic Design Parameters

Data regarding soil type and density to a depth of 100 feet is needed to designate a design class for the profile where liquefaction potential is not considered. However, we predict that the site could be classified **Class D** based on the limited data available.

A seismic impact zone is an area with a 10 percent or greater probability that the maximum horizontal acceleration in rock, expressed as a percentage of the earth's gravitational pull, will exceed 0.10g in 50 years.

Based on the maps and the site coefficients determined for **site class C** contained in the IBC, parameters as listed below are recommended by the Code:

Site Coefficients:

$$F_a = 1.60$$

$$F_v = 2.40$$

Maximum Earthquake Spectral Response Acceleration Parameters:

$$S_{MS} = 0.217^*$$

$$S_{M1} = 0.139$$

Design Spectral Response Acceleration Parameters:

$$S_{DS} = 0.144$$

$$S_{D1} = 0.093$$

\*Note: Acceleration used for seismic evaluation.

#### 4.2.1.2 Liquefaction

Liquefaction is a phenomenon where soil pore pressure builds up rapidly during cyclic loading causing a loss of shear strength and consequent significant ground movement both laterally and vertically. In layman's terms the soil turns into quick sand, losing ability to support load, and can spread laterally out from under foundations. Foundations sitting on sand that liquefies during an earthquake can sink into the soil.



Recent research<sup>1,2</sup> has shown that liquefaction potential exists not only in relatively clean sands, but also, under certain circumstances, in sands, silts and clayey soils of low plasticity ( $PI < 12$  or up to 20 if  $MC > 0.85 \times \text{Liquid Limit}$ ) with significant fines content. In order for liquefaction to be triggered, the water content of finer soils needs to be high (generally  $> 80-85\%$  of the Liquid Limit) and the density relatively low (assessed in terms of the SPT blow count generally where  $N1$  (SPT Value normalized for overburden pressure) is low). In addition, the frequency and magnitude of ground shaking has to reach a certain threshold, which is related to the soil properties and local geology.

The native soils are predominantly clayey gravel (GC) and lean clay with gravel (CL) over limestone. These characteristics taken together with the fact that the site is in a zone of relatively low maximum ground acceleration indicate a negligible risk of liquefaction.

#### **4.2.2 Erosional Processes**

Erosional processes in the area of study are limited to those produced by the drainage systems of Little Flint Creek. Due to the geology and the gentle relief of the site topography, erosion is minimal.

#### **4.3 Soil Stratigraphy**

Detailed on the attached boring logs are the specific types and depths of the various soil strata encountered. The logs show defined boundaries between various soil types, but in reality the transition between types is generally gradual.

The fill material in the containment berm consists primarily of stiff to very stiff lean clay (CL) or fat clay (CH) with gravel and medium dense clayey gravel (GC) or clayey sand (SC) with gravel overlying native soils which consist primarily of weathered limestone with layers of stiff to hard lean clay (CL) with gravel. The limestone encountered typically consisted of solid layers less than 14 inches thick. The Rock Quality Designation (RQD) of the cores is less than 25%. Atterberg Plasticity Indices of the tested soils ranged from 5 to 47.

### **5.0 GROUNDWATER OBSERVATIONS**

Groundwater was measured at each boring location during drilling operations and four piezometers were installed. Two new piezometers were installed on each embankment for the Primary and Secondary ash ponds. Groundwater levels in the piezometers have not been measured to date. Groundwater was found to range from elevation 1119 to 1135 (msl) in the open boreholes. Groundwater is anticipated to be between the lake elevation of 1140 and the primary and secondary pond elevations of 1146 and 1143 respectively

It should be noted, however, that seasonal groundwater conditions might vary throughout the year depending upon prevailing climatic conditions. This magnitude of variance will be largely dependent upon the fluctuation of pond and lake levels.

#### **5.1 Piezometers**

Four piezometers were installed for the two embankments at the site. These piezometers will be used to monitor the water level in the embankments. Piezometers were installed in the boring locations selected by AEP prior to the site work. The piezometers are numbered based on the

---

1 Idriss, I.M. and Boulanger, R.W., Semi Empirical Procedures for Evaluating Liquefaction Potential During Earthquakes, Invited Paper, 11th International Conference on Soil Dynamics and Earthquake Engineering, Berkley, CA, January 2004.

2 Seed, R. B., et al, Recent Advances in Soil Liquefaction Engineering: A Unified and Consistent Framework, 26th Annual ASCE Los Angeles Spring Seminar, April 2003.



boring number where each was installed (i.e. B-1 was installed at boring location B-1). Copies of the Well Logs and State of Arkansas Well Reports may be found in the Appendix.

Upon completion of drilling activities for the geotechnical borings, the piezometers were installed in the open borehole to the depth approximating the natural ground level. If the boring was deeper than the depth of proposed screening, the boring was backfilled with bentonite to the appropriate depth. The 2-inch piezometer was installed within the open borehole along with a 1-inch PVC pipe. Fresh water was pumped within the 1-inch PVC pipe until the water flowing back from the bottom of the borehole to the surface had thinned. The piezometers were constructed of schedule 40, 2-inch diameter, PVC pipe consisting of new, box-wrapped, flush-joint threaded screen (0.010-inch mill slot) and casing. This installation depth should measure the final groundwater elevation after the water through the embankment has stabilized. This is the depth predicted by the seepage analyses below.

The filter pack material placed around the well screen consisted of 20/40 silica sand. The filter pack sand was gravity placed into the annular space around the screen between the well and the borehole wall. Filter pack material was poured until the top of the filter pack extended two (2) feet above the top of the screen. Material thickness in the annular space was verified using a weighted fiberglass measuring tape or through the use of a 1-inch PVC pipe. The top of the filter pack was then sealed with bentonite pellets, which were allowed to gravity flow into the annular space to a minimum thickness of two (2) feet. The bentonite seal was hydrated with water. An additional bentonite seal was placed within the remaining portion of the annular seal to the surface. The piezometers were protected with flush mount surface completions.

## **5.2 Embankment Seepage Studies**

### **5.2.1 Seepage Losses and Pressures**

The anticipated water level due to seepage through the embankments was investigated based on the high water level anticipated in each individual pond using the computer program SEEP 2D by Environmental Modeling Systems, Incorporated. The seepage both through the embankment and through the foundation soils at each embankment location was estimated based on the permeability tests of soils encountered at the site. The permeabilities of representative samples of the soil ranged from  $2.4 \times 10^{-8}$  cm/sec to  $9.4 \times 10^{-9}$  cm/sec (test results included in the Appendix). Permeabilities of the weathered rock layers were not tested, but due to the possibility of interconnected voids, permeabilities of the rock mass could vary widely, estimated (in published literature for this kind of geology) to range from  $1 \times 10^{-3}$  cm/sec to  $1 \times 10^{-8}$  cm/sec. We understand that grout curtains that were installed around the perimeter to keep the reservoir filled to a useable level. This fact substantiates the existence of significant interconnected voids in the rock mass. Due to the high plasticity of the soil interlayered with rock seams, we anticipate that the permeabilities of the soil seams will be similar to those of the surficial clays tested. Based on the possibility of gravel seams in the fill as well as in the native soils, flows were also calculated by increasing the average flow rate (i.e. increasing the permeability) by a factor of 10 (i.e.,  $1 \times 10^{-8}$  cm/sec would become  $1 \times 10^{-7}$  cm/sec).

Seepage losses for the highest permeability predicted for the embankments are predicted at 0.03 gallon per day (gpd) per foot of dam length based on the assumptions above (which do not account for significant seepage losses in the voids in the rock mass).



<b>Table 5.2.1.1 – Permeability Test Results</b>			
<b>Boring</b>	<b>Depth</b>	<b>Unit Weight (pcf)</b>	<b>Permeability (cm/sec)</b>
B-1	18' - 20'	125.1	$1.5 \times 10^{-8}$
B-1	33' - 35'	130.5	$1.5 \times 10^{-8}$
B-2	8' - 10'	129.6	$9.4 \times 10^{-9}$
B-2	23' - 25'	131.3	$2.4 \times 10^{-8}$
B-7	5' - 7'	127.1	$2.0 \times 10^{-8}$

<b>Table 5.2.1.2 – Embankment Seepage Rates</b>	
<b>Embankment</b>	<b>Seepage Rates (Cubic Feet per Day per Foot) Max/Min</b>
Primary Ash Pond	$4 \times 10^{-3} / 5 \times 10^{-4}$
Secondary Ash Pond	$4 \times 10^{-3} / 1 \times 10^{-4}$

The water levels at the piezometers are predicted to reach slightly above the average of the upstream (pond) and downstream (lake) normal pool elevations. Water levels approaching the pond level could indicate a seepage pressure not anticipated in this design. Levels found to be within 1 foot of the pond levels should be brought to the attention of E TTL for additional study.

## **6.0 POND EMBANKMENT SECTIONS**

The berm heights ranged from 35 feet for the Secondary Ash Pond to a maximum of around 46 feet for the Primary Ash Pond.

### **6.1 Slope Stability Analysis**

All embankment slopes must be stable with respect to shear failure through the embankment and/or the foundation strata. The existing slopes are standing (and have been doing so for approximately 30 years) with no obvious slope failures. Therefore, all slopes must have a Factor of Safety at or above 1 under current conditions. However, according to the Corps of Engineers, the Factor of Safety for long term stability should be a minimum of 1.5 for all new construction. Older dams with a long history may be less, but for this study, a minimum of 1.5 was still utilized. This study was conducted to assure that the embankments meet the minimum Safety Factors.

Slope stability was evaluated using the computer program Geostase developed by Gregory Geotechnical Software (Geostase is the latest version of GSTABL7 and has not been released generally yet). The program is capable of calculating the factor of safety for potential failure surfaces using several different methods. The analyses for this project were conducted using the modified Bishop method as this was believed to be the most appropriate approach. The program has an automatic search routine for determining the minimum factor of safety. The resulting analyses are depicted graphically and are included in the Appendix.

The surveyed boring elevations were used for an embankment top elevation and the original topographical maps along with the construction plans for the embankments were used in order to determine cross sections for the stability analyses.

What was believed to be the “worst case” embankment cross section (based on visual observations during the initial site visit) was used in the analysis. The tallest section was chosen. The soil strengths were modeled using 85 percent of the strength test values determined from testing where



a test was conducted. Where no triaxial test was conducted, average strength values of the fill and native soils were used based on the soil types as well as correlations with SPT blow counts. These average results were also reduced by 15 percent. Reductions of 15% were used in an attempt to accommodate potential variations in the soil as well as to compensate for the limited amount of data. Due to the amount of gravel in the samples, only three triaxial tests were possible. The original embankment subgrade was assumed to be gravel and not solid rock based on the poor recovery (RQD<25%), the thin layers of accretion rock cored and significant clay seams found in the samples. Based on the rounded edges, the surficial native soils are gravel in a clay matrix. We have assumed that these subgrade soils extend deeper than first layer of solid rock encountered since the rock seams were still thin in most locations and in order to use a more conservative basis for analysis. Results of the Triaxial tests are summarized in **Table 6.1.1** below. The rock mass strength was determined using the strength of the cores tested and the computer program RocLab 1.0 from Rockscience. This program predicts the strength of the entire rock mass based on the Hoek-Brown criterion and backcalculates a cohesion and friction angle for the rock mass. The test results are included in the Appendix.

Table 6.1.1 - Summary of Soil Test Results							
Boring	Depth	Fill or Native	Soil Classification	Effective Stress Parameters		Total Stress Parameters	
				Friction Angle	Cohesion (psf)	Friction Angle	Cohesion (psf)
B-2	3'-7'	Fill	CH	33.7	0	15.9	345
B-2	23'-35'	Native	CL	33.0	90	18.3	275
B-3	3'-7'	Fill	CL	24.0	460	14.1	575
B-1	43'	Native Rock	LS	38.5	1000	38.5	1000

Three cases were analyzed for each slope: steady-state (long term), steady state with seismic loads and rapid drawdown of the water in the ash ponds. In the rapid drawdown study, the water in the ash ponds is removed, but the water level in the embankment remains. For the evaluation of steady-state conditions, the soils were evaluated using *effective* stress parameters. For the rapid drawdown case the slopes were evaluated using *total* stress parameters. Graphical representations of the slope stability results are included in the **Appendix**. Results of the analysis are summarized in **Table 6.1.2**, below.

Table 6.1.2 Slope Stability Analyses Results			
Pond	Steady State Factor of Safety	Steady State with Seismic Factor of Safety	Rapid Drawdown Factor of Safety
Primary Ash Pond	1.9	1.3	1.2
Secondary Ash Pond	1.6	1.2	1.5

It should be noted that due to the karst nature of the rock at the site, factors other than those considered in this analysis may affect the stability of the slopes in question. Solution cavities of varying sizes characterize this geology. It was not possible within the limited scope of this





investigation to map cavities. Consequently, no cavities were assumed to be present. However, no significant cavities were encountered in any of the borings of this study other than vuggy rock. In addition, the strength obtained from compression testing of solid rock cores was reduced significantly using the GSI approach in an attempt to predict the strength of vuggy rock used in the analysis.

## 6.2 Slope Protection

Earthen embankment slopes require some form of protection from excessive erosion. A good cover of approved grasses should provide adequate slope protection. The embankments appeared to have adequate vegetation, but some of the locations had been recently cleared of trees. Bushes and trees of two feet or more in height are not considered satisfactory slope protection because of the harmful effect on grass and the hazards of tree roots.

A routine and periodic maintenance program should be implemented to prevent excessive growth. Animal control should also be considered an integral part of routine embankment maintenance.

## 7.0 EMBANKMENT MONITORING

Visual drive-by inspections and cursory on-foot inspections should be performed in accordance with AEP requirements. As a minimum, dam safety inspections should be conducted biannually.

Should any unusual occurrences be noted in connection with the operation of the dams, either as a result of the cursory drive-by inspections or as the result of the detailed dam safety inspections, AEP Geotechnical Engineering, and E TTL Engineers & Consultants Inc. should be immediately notified for evaluation and development, if necessary, of a Remedial Action Plan.

## 8.0 LIMITATIONS

Geotechnical design work is characterized by the presence of a calculated risk that soil and groundwater conditions may not have been fully revealed by the exploratory borings. This risk derives from the practical necessity of basing interpretations and design conclusions on a limited sampling of the subsoil stratigraphy at the project site. The number of borings and spacing is chosen in such a manner as to decrease the possibility of undiscovered anomalies, while considering the nature of loading, size and cost of the project. The recommendations given in this report are based upon the conditions that existed at the boring locations at the time they were drilled. The term "existing groundline" or "existing subgrade" refers to the ground elevations and soil conditions at the time of our field operations.

It is conceivable that soil conditions throughout the site may vary from those observed in the exploratory borings. If such discontinuities do exist, they may not become evident until construction begins or possibly much later. Consequently, careful observations by the geotechnical engineer must be made of the construction as it progresses to help detect significant and obvious deviations of actual conditions throughout the project area from those inferred from the exploratory borings. Should any conditions at variance with those noted in this report be encountered during construction, this office should be notified immediately so that further investigations and supplemental recommendations can be made.

This company is not responsible for the conclusions, opinions, or recommendations made by others based on the contents of this report. The recommendations made in this report are applicable only to the proposed scope of work as defined in **SECTION 2.0 PROJECT DESCRIPTION** and may not be used for any other work without the express written consent of E TTL Engineers. The purpose of



this study is only as stated elsewhere herein and is not intended to comply with the requirements of 30 TAC 330 Subchapter T regarding testing to determine the presence of a landfill. Our professional services have been performed, our findings obtained, and our recommendations prepared in accordance with generally accepted geotechnical engineering principles and practices. No warranties are either expressed or implied.



## APPENDIX

### I.0 FIELD OPERATIONS

Subsurface conditions were defined by 7 sample core borings drilled to depths ranging from 30 to 50 feet and. E TTL personnel drilled the borings at locations selected based on a site visit in conjunction with the client. Field boring logs were prepared as drilling and sampling progressed. The final boring logs are also included in the Appendix. Descriptive terms and symbols used on the logs are in accordance with the Unified Soil Classification System (ASTM D 2487). A reference key is provided on the final page of this report.

Truck and track-mounted drill rigs utilizing dry auger drilling procedures were used to advance the borings. Samples were continuous in the upper 10 feet and at 5 feet intervals below 10 feet (or at major strata changes). Soils were sampled by means of a 1 3/8-inch I.D. by 24-inch long split-spoon sampler driven into the bottom of the borehole in accordance with ASTM D 1586 procedures. In conjunction with this sampling technique, the Standard Penetration Test was conducted by recording the N-value, which is the number of blows required by a 140-pound weight falling 30 inches to drive a split-spoon sampler 1 foot into the ground. For very dense strata, the number of blows is limited to a maximum of 50 blows within a 6-inch increment. Where possible, the sampler is "seated" six inches before the N-value is determined. The N-value obtained from the Standard Penetration Test provides an approximate measure of the relative density, which correlates with the shear strength of soil. The disturbed samples were removed from the sampler, logged, packaged, and transported to the laboratory for further identification and classification.

Soils were sampled by means of a 3-inch O.D. by 24-inch long thick-walled Shelby Tube sampler. Using the drilling rig's hydraulic pressure, the sampler was pushed smoothly into the bottom of the borehole. The consistency of these samples was measured in the field by a calibrated pocket penetrometer. These values, recorded in tons per square foot, are shown on the boring logs. Such samples were extruded in the field, logged, sealed to maintain *in situ* conditions, and packaged for transport to the laboratory.

All boreholes were backfilled with grout after collecting final groundwater readings. Samples obtained during our field studies and not consumed by laboratory testing procedures will be retained in our Tyler office free of charge for a period of 60 days. To arrange storage beyond this point in time, please contact the Tyler office.

### II.0 LABORATORY TESTING

Upon return to the laboratory, a geotechnical engineer visually examined all samples and several specimens were selected for representative identification of the substrata. By determining the Atterberg liquid and plastic limits (ASTM D 4318) and percentage of fines passing the No. 200 sieve (ASTM D 1140), field classification of the various strata was verified. Also conducted were natural moisture content tests (ASTM D 2216).

Size distribution of several soil samples was determined using a Hydrometer test (ASTM D 422). Permeabilities (ASTM D 5084) were also performed on a representative samples.

Strength characteristics of the cohesive substrata were evaluated by conducting unconsolidated, undrained triaxial compression tests (ASTM D 2850) on selected undisturbed field samples obtained with the Shelby tube sampler. Direct Shear tests (ASTM D 3080) were performed on undisturbed samples retrieved during drilling operations. The results of these tests are either presented in the individual log of boring provided in this Appendix or as a separate result behind the logs in the Appendix.





**ETTL  
ENGINEERS &  
CONSULTANTS**

MAIN OFFICE  
1717 Edget Erwin  
Tyler, Texas 75702  
(903) 595-4421

**FLINT CREEK  
POWER PLANT  
GENTRY, ARKANSAS**

**PLATE 1 - PLAN OF BORINGS**

JOB NO.: G3243-09

DATE: JAN. 2010

SCALE: N.T.S.

APPROVED BY:

DRAWN BY:  
K.C.R.

# Flint Creek Power Station, Gentry, Arkansas

## Primary Ash Pond, Steady State

EST Geotechnical Consultants Inc. Files\3243-09 AEP Flint Creek Power Plant Bottom Ash Ponds Geo Stability Analysis\Slope Stability\Primary SS.in

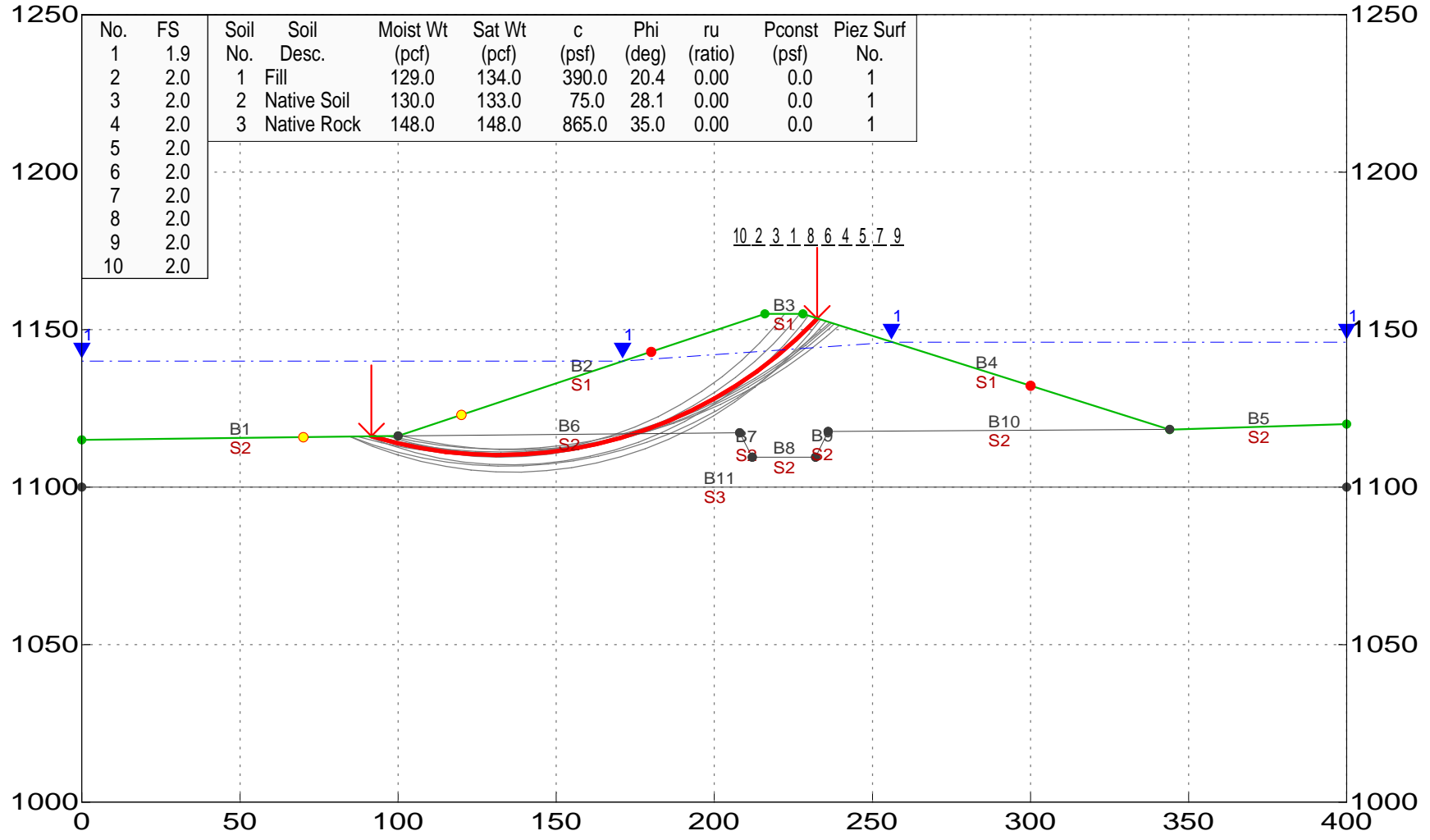

**GEOSTASE FSmin = 1.9**

Modified Bishop Method

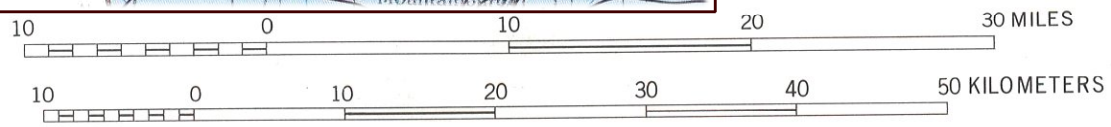
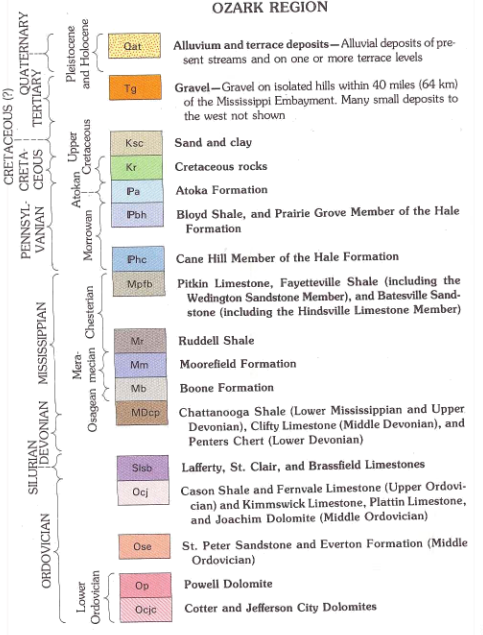
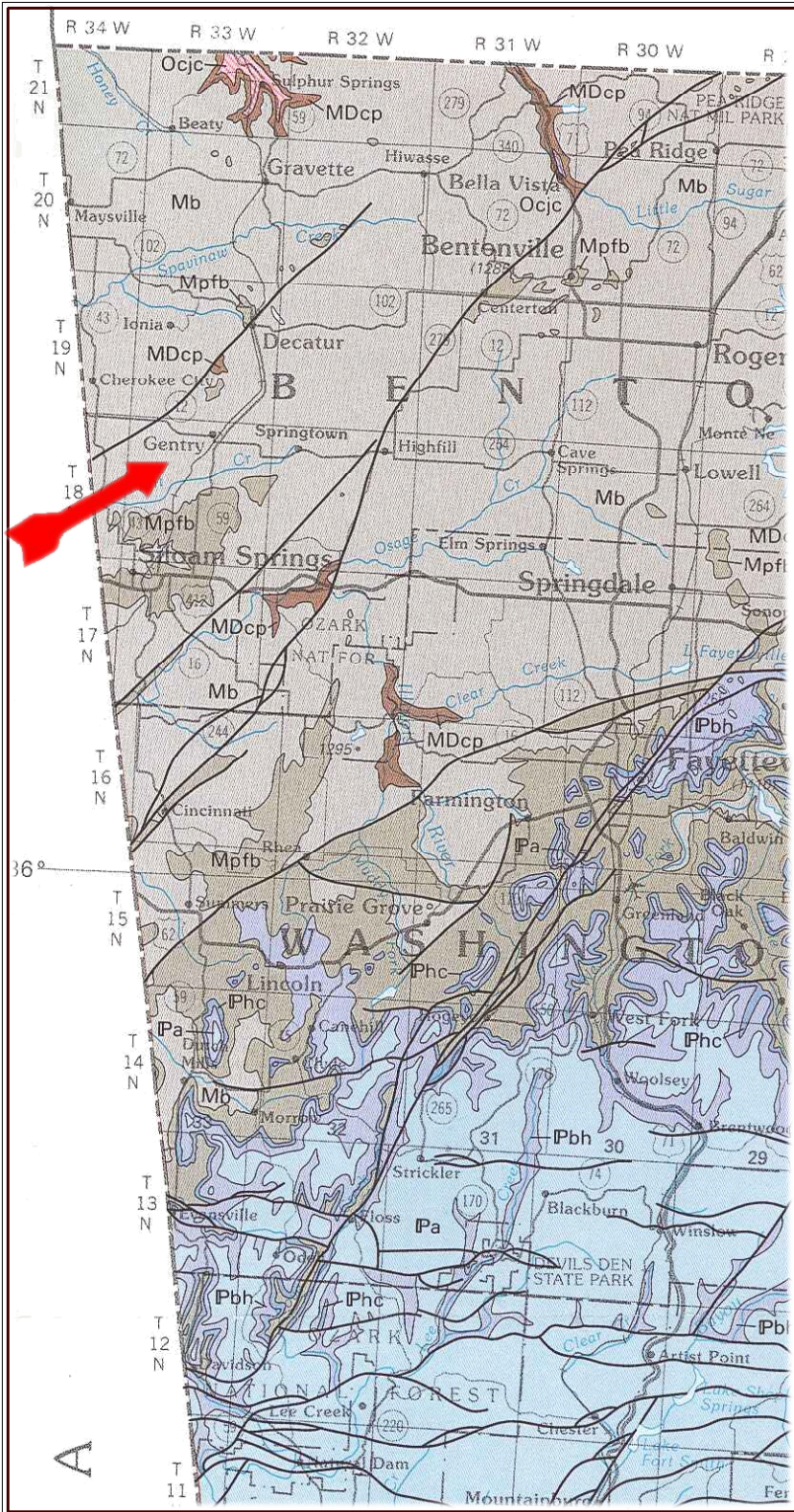

NATIONAL GEODETIC VERTICAL DATUM OF 1929

**GEOLOGIC  
MAP OF  
ARKANSAS**

**ETTL**  
**ENGINEERS &  
CONSULTANTS**  
MAIN OFFICE  
1717 East Erwin  
Tyler, Texas 75702  
(903) 595-4421

**SITE  
SURFACE  
GEOLOGY**

JOB NO.: G3243-09
DATE: 1993
SCALE: 1:500,000

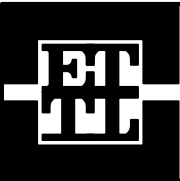

**ETTL  
ENGINEERS &  
CONSULTANTS**

MAIN OFFICE  
1717 East Erwin  
Tyler, Texas 75702  
(903) 595-4421

**LOG OF BORING B-1**

**PROJECT:** Flint Creek Power Plant  
Gentry, Arkansas

**PROJECT NO.:** G3243-09

**BORING TYPE:** Flight Auger

**DATE** 11/3/09  
**SURFACE ELEVATION** 1154.8

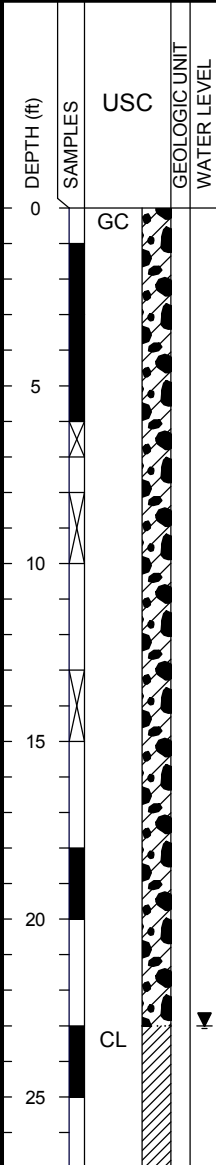

**MATERIAL DESCRIPTION**

CLAYEY GRAVEL(GC) red and tan

--dense  
--red, tan, and white  
--medium dense

--native soil  
--gray, tan, and red; moist

LEAN CLAY(CL) red and tan; saturated

FIELD STRENGTH DATA	BLOW COUNT				DRY DENSITY (pcf)	COMPRESSIVE STRENGTH (tsf)	FAILURE STRAIN (%)	CONFINING PRESSURE (psi)	Natural Moisture Content and Atterberg Limits			MOISTURE CONTENT (%)	ATTERBERG LIMITS(%)			MINUS #200 SIEVE (%)	OTHER TESTS PERFORMED (Page Ref. #)
	20	40	60	80					Plastic Limit	Moisture Content	Liquid Limit		LL	PL	PI		
	1	2	3	4													
P=3.5																	
P=1.5												13	30	16	14	32	+40Sieve=61%, +4 Sieve=55%
N=43																	
N=17												11	30	16	14	23	+40Sieve=71%, +4 Sieve=62%
N=25																	
P=2.5												12	43	16	27	28	+40Sieve=64%, +4 Sieve=56%
P=4.5+																	

Water Level Est.: Measured: Perched:

Water Observations: Seepage @ 23' while drilling. Water level @ 23' and open to 39' upon completion and after 30 minutes.

Key to Abbreviations:  
N - SPT Data (Blows/Ft)  
P - Pocket Penetrometer (tsf)  
T - Torvane (tsf)  
L - Lab Vane Shear (tsf)

Notes: GPS Coordinates: N 36°15.00', W 94°31.496'

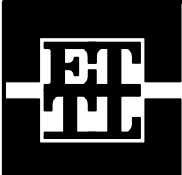

**ETTL  
ENGINEERS &  
CONSULTANTS**

MAIN OFFICE  
1717 East Erwin  
Tyler, Texas 75702  
(903) 595-4421

**LOG OF BORING B-1**

**PROJECT:** Flint Creek Power Plant  
Gentry, Arkansas

**PROJECT NO.:** G3243-09

**BORING TYPE:** Flight Auger

**DATE** 11/3/09  
**SURFACE ELEVATION**  
1154.8

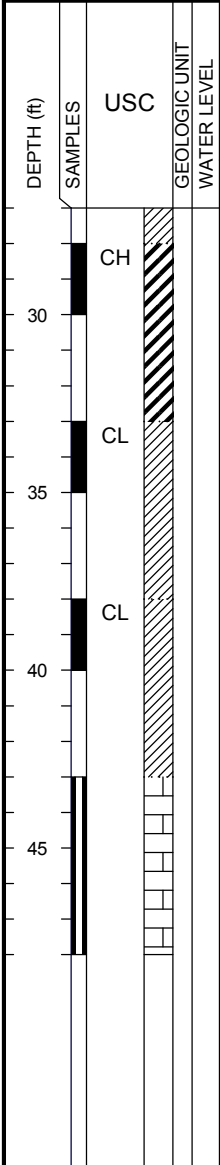

**MATERIAL DESCRIPTION**

SANDY FAT CLAY(CH) hard; red and tan;  
with gravel

LEAN CLAY(CL) very stiff; red and tan

LEAN CLAY WITH SAND(CL) very stiff; red  
and gray

LIMESTONE moderately strong; limestone  
seams ~16"; gray; crystalline clay; thick  
bedded; fresh; unfeatured  
--RQD<0.25

Bottom of Boring @ 48'

FIELD STRENGTH DATA	BLOW COUNT				DRY DENSITY (pcf)	COMPRESSIVE STRENGTH (tsf)	FAILURE STRAIN (%)	CONFINING PRESSURE (psi)	Natural Moisture Content and Atterberg Limits			MOISTURE CONTENT (%)	ATTERBERG LIMITS (%)			MINUS #200 SIEVE (%)	OTHER TESTS PERFORMED (Page Ref. #)
	20	40	60	80					Plastic Limit	Moisture Content	Liquid Limit		LL	PL	PI		
	1	2	3	4													
P=4.5+									50	20	30	54			+40Sieve=40%, +4 Sieve=34%		
P=2.5																	
P=3.5									55	18	23	83			+40Sieve=7%, +4 Sieve=0%		
					151	326.00		0									

Water Level Est.: Measured: Perched:   
Water Observations: Seepage @ 23' while drilling. Water level @ 23' and open to 39' upon completion and after 30 minutes.

Key to Abbreviations:  
N - SPT Data (Blows/Ft)  
P - Pocket Penetrometer (tsf)  
T - Torvane (tsf)  
L - Lab Vane Shear (tsf)

Notes:  
GPS Coordinates: N 36°15.00', W 94°31.496'



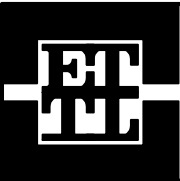

**ETTL  
ENGINEERS &  
CONSULTANTS**

MAIN OFFICE  
1717 East Erwin  
Tyler, Texas 75702  
(903) 595-4421

**LOG OF BORING B-2**

**PROJECT:** Flint Creek Power Plant  
Gentry, Arkansas

**PROJECT NO.:** G3243-09

**BORING TYPE:** Flight Auger

**DATE** 11/3/09  
**SURFACE ELEVATION** 1155.1

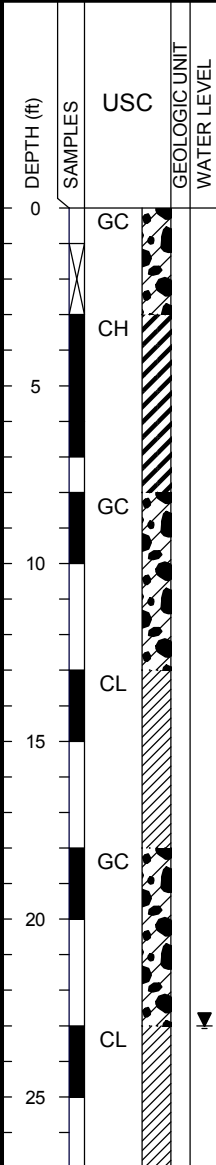

**MATERIAL DESCRIPTION**

CLAYEY GRAVEL(GC) medium dense; red and tan; with gravel

FAT CLAY WITH SAND(CH) stiff; red and tan

CLAYEY GRAVEL(GC) medium dense; red and tan; with sand and gravel

SANDY LEAN CLAY(CL) red and tan; with gravel

CLAYEY GRAVEL(GC) medium dense; red and tan; moist  
--native soil

SANDY LEAN CLAY(CL) very stiff; red and tan; with gravel

FIELD STRENGTH DATA	BLOW COUNT				DRY DENSITY (pcf)	COMPRESSIVE STRENGTH (tsf)	FAILURE STRAIN (%)	CONFINING PRESSURE (psi)	Natural Moisture Content and Atterberg Limits			MOISTURE CONTENT (%)				OTHER TESTS PERFORMED (Page Ref. #)
	20	40	60	80					Plastic Limit	Moisture Content	Liquid Limit	LIQUID LIMIT (LL)	PLASTIC LIMIT (PL)	PLASTICITY INDEX (PI)	MINUS #200 SIEVE (%)	
	1	2	3	4												
N=18	●							55	44	20	24	40	+40 Sieve=52%, +4 Sieve=42%			
P=4.5+				■				50	61	26	35	80	+40 Sieve=7%, +4 Sieve=2%			
P=2.0		■						55								
P=3.5				■				55	62	18	44	47	+40 Sieve=49%, +4 Sieve=37%			
P=2.0		■						55	38	15	23	13	+40 Sieve=81%, +4 Sieve=76%			
P=3.0				■												

Water Level Est.: ▽ Measured: ▼ Perched: ▼  
Water Observations: Seepage @ 20' while drilling. Water level @ 20' and open upon completion and after 1 hour.

Key to Abbreviations:  
N - SPT Data (Blows/Ft)  
P - Pocket Penetrometer (tsf)  
T - Torvane (tsf)  
L - Lab Vane Shear (tsf)

Notes: GPS Coordinates: N 36°15.025', W 94°31.467'

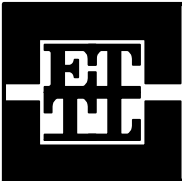

**ETTL  
ENGINEERS &  
CONSULTANTS**

MAIN OFFICE  
1717 East Erwin  
Tyler, Texas 75702  
(903) 595-4421

**LOG OF BORING B-2**

**PROJECT:** Flint Creek Power Plant  
Gentry, Arkansas

**PROJECT NO.:** G3243-09

**BORING TYPE:** Flight Auger

**DATE** 11/3/09  
**SURFACE ELEVATION** 1155.1

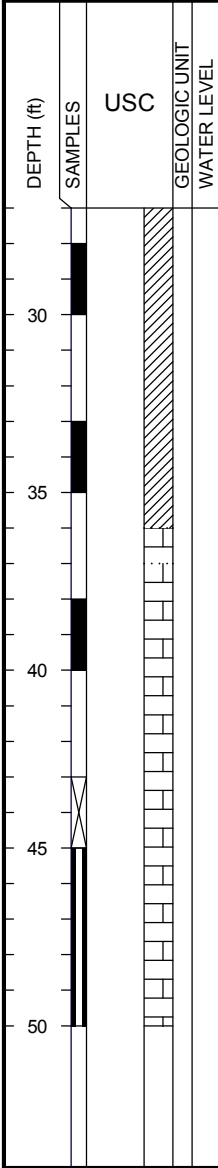

**MATERIAL DESCRIPTION**

LIMESTONE ~ 14" thick layer  
LIMESTONE ~ 8" thick limestone ledge

--rock cuttings; RQD<0.25

--solid rock seam @ 48'

Bottom of Boring @ 50'

FIELD STRENGTH DATA	BLOW COUNT				DRY DENSITY (pcf)	COMPRESSIVE STRENGTH (tsf)	FAILURE STRAIN (%)	CONFINING PRESSURE (psi)	Natural Moisture Content and Atterberg Limits			MOISTURE CONTENT (%)	ATTERBERG LIMITS (%)			OTHER TESTS PERFORMED (Page Ref. #)
	20	40	60	80					Plastic Limit	Moisture Content	Liquid Limit		LL	PL	PI	
	1	2	3	4												
	PPR (tsf)	Torvane (tsf)														
P=3.5											19	45	17	28	60	+40Sieve=35%, +4 Sieve=28%
P=3.9																
SF											24	53	22	31	7	+40Sieve=92%, +4 Sieve=86%
N=50/0.5"																
					171.00			0								
					148											

Water Level Est.: Measured: Perched:

Water Observations: Seepage @ 20' while drilling. Water level @ 20' and open upon completion and after 1 hour.

Key to Abbreviations:  
N - SPT Data (Blows/Ft)  
P - Pocket Penetrometer (tsf)  
T - Torvane (tsf)  
L - Lab Vane Shear (tsf)

Notes: GPS Coordinates: N 36°15.025', W 94°31.467'

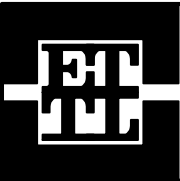

**ETTL  
ENGINEERS &  
CONSULTANTS**

MAIN OFFICE  
1717 East Erwin  
Tyler, Texas 75702  
(903) 595-4421

**LOG OF BORING B-3**

**PROJECT:** Flint Creek Power Plant  
Gentry, Arkansas

**PROJECT NO.:** G3243-09

**BORING TYPE:** Flight Auger

**DATE** 11/4/09  
**SURFACE ELEVATION**  
1154.7

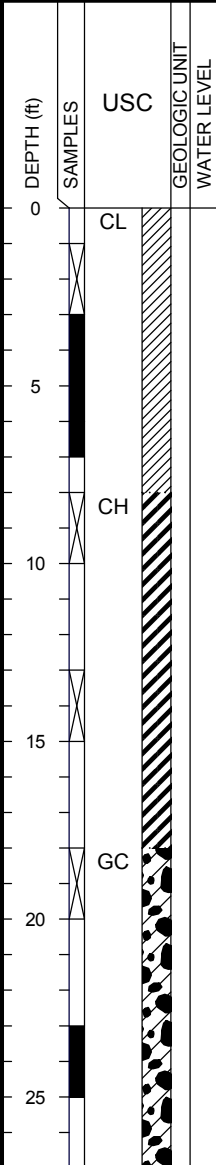

**MATERIAL DESCRIPTION**

**CL**  
SANDY LEAN CLAY(CL) very stiff; gray and tan; with gravel  
--brown and red; with gravel

**CH**  
SANDY FAT CLAY(CH) stiff; tan and red; with gravel  
--gray and tan; with gravel  
--very stiff

**GC**  
CLAYEY GRAVEL(GC) medium dense; gray and tan; with gravel  
--native soil  
--brown

FIELD STRENGTH DATA	BLOW COUNT		DRY DENSITY (pcf)	COMPRESSIVE STRENGTH (tsf)	FAILURE STRAIN (%)	CONFINING PRESSURE (psi)	Natural Moisture Content and Atterberg Limits			MOISTURE CONTENT (%)	ATTERBERG LIMITS (%)			OTHER TESTS PERFORMED (Page Ref. #)	
	20	40					60	80	LIQUID LIMIT (LL)		PLASTIC LIMIT (PL)	PLASTICITY INDEX (PI)	MINUS #200 SIEVE (%)		
	1	2					3	4							Plastic Limit
N=19	●									20	37	15	22	63	+40 Sieve=23%, +4 Sieve=18%
P=2.0		■													
P=1.6		■													
N=11	●									19	64	17	47	57	+40 Sieve=28%, +4 Sieve=19%
N=27	●														
N=22	●									19	27	18	9	42	+40 Sieve=51%, +4 Sieve=37%
										13	30	17	13	39	+40 Sieve=54%, +4 Sieve=42%

Water Level Est.:  Measured:  Perched:   
Water Observations: Dry and open to 31' upon completion.

Key to Abbreviations:  
N - SPT Data (Blows/Ft)  
P - Pocket Penetrometer (tsf)  
T - Torvane (tsf)  
L - Lab Vane Shear (tsf)

Notes:  
GPS Coordinates: N 36°15.116', W 94°31.449'

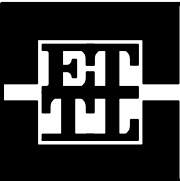

**ETTL  
ENGINEERS &  
CONSULTANTS**

MAIN OFFICE  
1717 East Erwin  
Tyler, Texas 75702  
(903) 595-4421

**LOG OF BORING B-3**

**PROJECT:** Flint Creek Power Plant  
Gentry, Arkansas

**PROJECT NO.:** G3243-09

**BORING TYPE:** Flight Auger

**DATE** 11/4/09  
**SURFACE ELEVATION** 1154.7

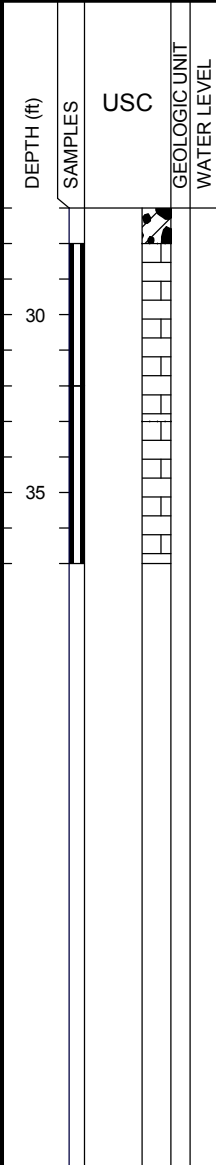

MATERIAL DESCRIPTION	
0 - 30	LIMESTONE rock cuttings --RQD<0.25
30 - 35	LIMESTONE --RQD<0.25
35 - 37	Bottom of Boring @ 37'

FIELD STRENGTH DATA	● BLOW COUNT ●			
	20	40	60	80
	▲ Qu (tsf) ▲			
	1	2	3	4
FIELD STRENGTH DATA	■ PPR (tsf) ■			
	1.0	2.0	3.0	4.0
	◆ Torvane (tsf) ◆			
	1.0	2.0	3.0	4.0
P=4.0				■

DRY DENSITY (pcf)	COMPRESSIVE STRENGTH (tsf)	FAILURE STRAIN (%)	CONFINING PRESSURE (psi)	Natural Moisture Content and Atterberg Limits		
				Plastic Limit	Moisture Content	Liquid Limit
					●	

MOISTURE CONTENT (%)	ATTERBERG LIMITS (%)			MINUS #200 SIEVE (%)	OTHER TESTS PERFORMED (Page Ref. #)
	LIQUID LIMIT	PLASTIC LIMIT	PLASTICITY INDEX		
LL	PL	PI			

Water Level Est.: ▽ Measured: ▼ Perched: ▼  
Water Observations: Dry and open to 31' upon completion.

Key to Abbreviations:  
N - SPT Data (Blows/Ft)  
P - Pocket Penetrometer (tsf)  
T - Torvane (tsf)  
L - Lab Vane Shear (tsf)

Notes: GPS Coordinates: N 36°15.116', W 94°31.449'

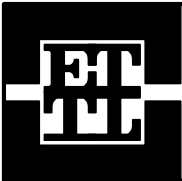

**ETTL  
ENGINEERS &  
CONSULTANTS**

MAIN OFFICE  
1717 East Erwin  
Tyler, Texas 75702  
(903) 595-4421

**LOG OF BORING B-4**

**PROJECT:** Flint Creek Power Plant  
Gentry, Arkansas

**PROJECT NO.:** G3243-09

**BORING TYPE:** Flight Auger

**DATE** 11/4/09  
**SURFACE ELEVATION** 1154.9

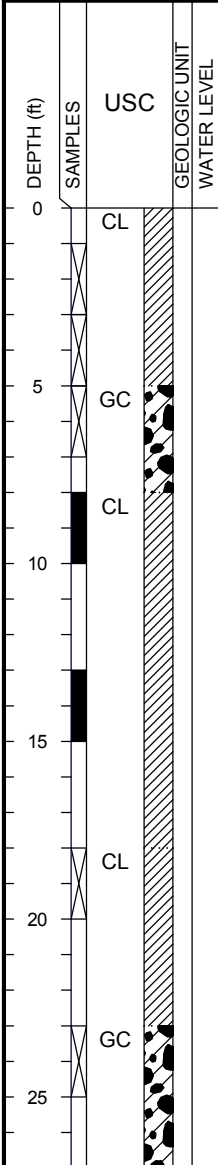

**MATERIAL DESCRIPTION**

SANDY LEAN CLAY(CL) stiff; tan and gray;  
with gravel

CLAYEY GRAVEL(GC) medium dense; tan  
and red

LEAN CLAY WITH GRAVEL(CL) stiff; red  
and tan

--reddish brown and tan

SANDY LEAN CLAY(CL) very stiff; tan and  
gray; with gravel  
--native soil

CLAYEY GRAVEL(GC) medium dense; tan  
and red; with gravel

FIELD STRENGTH DATA	BLOW COUNT				DRY DENSITY (pcf)	COMPRESSIVE STRENGTH (tsf)	FAILURE STRAIN (%)	CONFINING PRESSURE (psi)	Natural Moisture Content and Atterberg Limits			ATTERBERG LIMITS(%)				OTHER TESTS PERFORMED (Page Ref. #)	
	Qu (tsf)								Plastic Limit	Moisture Content	Liquid Limit	LIQUID LIMIT	PLASTIC LIMIT	PLASTICITY INDEX	MINUS #200 SIEVE (%)		
	1	2	3	4													
N=8	●			●					20	40	17	23	52	+40Sieve=42%, +4 Sieve=30%			
N=13	●			●					10	48	20	28	22	+40Sieve=71%, +4 Sieve=62%			
N=13	●			●													
P=1.5				■													
P=4.5+				■					21	28	16	12	51	+40Sieve=44%, +4 Sieve=31%			
N=21	●			●													
N=18	●			●					9	45	20	25	38	+40Sieve=55%, +4 Sieve=45%			

Water Level Est.: ▽ Measured: ▼ Perched: ▼  
Water Observations: Dry and open to 36' upon completion and after 30 minutes.

Key to Abbreviations:  
N - SPT Data (Blows/Ft)  
P - Pocket Penetrometer (tsf)  
T - Torvane (tsf)  
L - Lab Vane Shear (tsf)

Notes: GPS Coordinates: N 36°15.149', W 94°31.463'

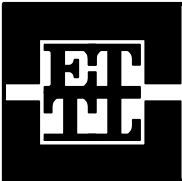

**ETTL  
ENGINEERS &  
CONSULTANTS**

MAIN OFFICE  
1717 East Erwin  
Tyler, Texas 75702  
(903) 595-4421

**LOG OF BORING B-4**

**PROJECT:** Flint Creek Power Plant  
Gentry, Arkansas

**PROJECT NO.:** G3243-09

**BORING TYPE:** Flight Auger

**DATE** 11/4/09  
**SURFACE ELEVATION**  
1154.9

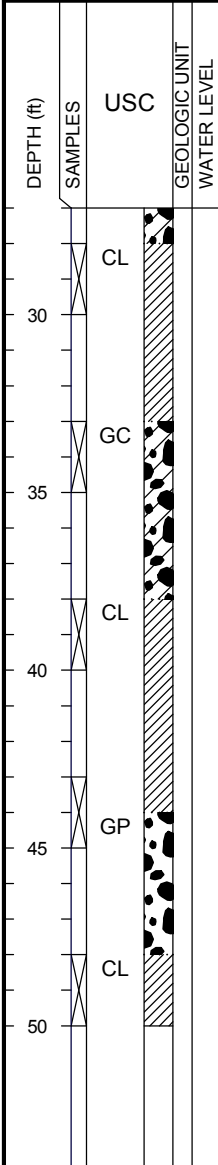

**MATERIAL DESCRIPTION**

FIELD STRENGTH DATA	BLOW COUNT				DRY DENSITY (pcf)	COMPRESSIVE STRENGTH (tsf)	FAILURE STRAIN (%)	CONFINING PRESSURE (psi)	Natural Moisture Content and Atterberg Limits			MOISTURE CONTENT (%)	ATTERBERG LIMITS (%)			OTHER TESTS PERFORMED (Page Ref. #)	
	20	40	60	80					Plastic Limit	Moisture Content	Liquid Limit		LL	PL	PI		MINUS #200 SIEVE (%)
N=19	●																
N=8	●																
N=18	●								●			18	43	16	27	60	+40 Sieve=32%, +4 Sieve=25%
N=5	●																
N=10	●																

Water Level Est.: ▽ Measured: ▼ Perched: ▼

Water Observations: Dry and open to 36' upon completion and after 30 minutes.

Key to Abbreviations:  
N - SPT Data (Blows/Ft)  
P - Pocket Penetrometer (tsf)  
T - Torvane (tsf)  
L - Lab Vane Shear (tsf)

Notes: GPS Coordinates: N 36°15.149', W 94°31.463'

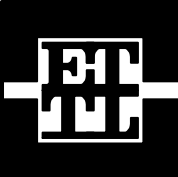

**ETTL  
ENGINEERS &  
CONSULTANTS**

MAIN OFFICE  
1717 East Erwin  
Tyler, Texas 75702  
(903) 595-4421

**LOG OF BORING B-5**

**PROJECT:** Flint Creek Power Plant  
Gentry, Arkansas

**PROJECT NO.:** G3243-09

**BORING TYPE:** Flight Auger

**DATE** 11/5/09  
**SURFACE ELEVATION** 1142.6

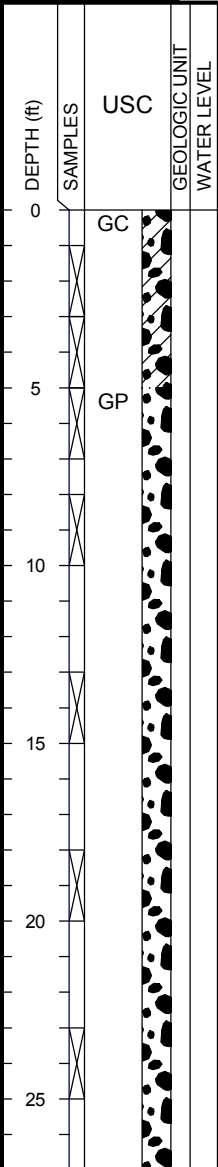

**MATERIAL DESCRIPTION**

CLAYEY GRAVEL(GC) very dense; red and white  
--dense

POORLY GRADED GRAVEL(GP) very dense; white; with limestone gravel  
--very dense

FIELD STRENGTH DATA	BLOW COUNT		DRY DENSITY (pcf)	COMPRESSIVE STRENGTH (tsf)	FAILURE STRAIN (%)	CONFINING PRESSURE (psi)	Natural Moisture Content and Atterberg Limits			MOISTURE CONTENT (%)	ATTERBERG LIMITS(%)			MINUS #200 SIEVE (%)	OTHER TESTS PERFORMED (Page Ref. #)
	20	40					Plastic Limit	Moisture Content	Liquid Limit		LL	PL	PI		
	1	2													
●	▲	▲													
	▲	Qu (tsf)													
	■	PPR (tsf)													
	◆	Torvane (tsf)													
	◆	Torvane (tsf)													
N=62															
N=39										32	53	25	28	41	+40 Sieve=55%, +4 Sieve=41%
N=71															
N=50/2"										20				4	+40 Sieve=95%, +4 Sieve=76%
N=40															
N=10															
N=26															

Water Level Est.:  Measured:  Perched:   
Water Observations: Dry and open to 20' upon completion and after 30 minutes.

Key to Abbreviations:  
N - SPT Data (Blows/Ft)  
P - Pocket Penetrometer (tsf)  
T - Torvane (tsf)  
L - Lab Vane Shear (tsf)

Notes: GPS Coordinates: N 36°15.176', W 94°31.492'

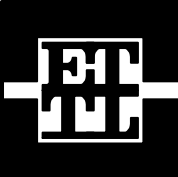

**ETTL  
ENGINEERS &  
CONSULTANTS**

MAIN OFFICE  
1717 East Erwin  
Tyler, Texas 75702  
(903) 595-4421

**LOG OF BORING B-5**

**PROJECT:** Flint Creek Power Plant  
Gentry, Arkansas

**PROJECT NO.:** G3243-09

**BORING TYPE:** Flight Auger

**DATE** 11/5/09  
**SURFACE ELEVATION** 1142.6

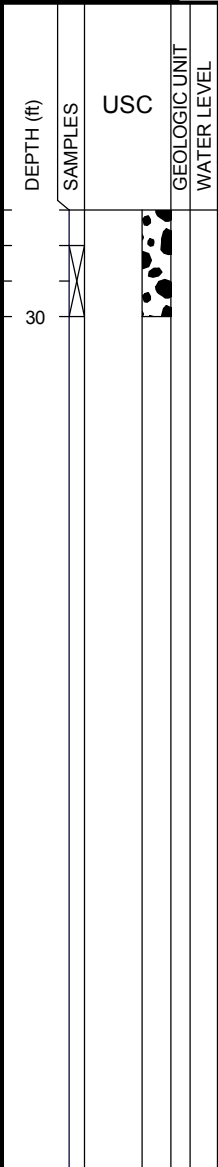

**MATERIAL DESCRIPTION**

--no recovery

Bottom of Boring @ 30'

FIELD STRENGTH DATA	● BLOW COUNT ●			
	20	40	60	80
	▲ Qu (tsf) ▲			
	1	2	3	4
	■ PPR (tsf) ■			
	1.0	2.0	3.0	4.0
	◆ Torvane (tsf) ◆			
	1.0	2.0	3.0	4.0

N=50/3"

DRY DENSITY (pcf)	COMPRESSIVE STRENGTH (tsf)	FAILURE STRAIN (%)	CONFINING PRESSURE (psi)
-------------------	----------------------------	--------------------	--------------------------

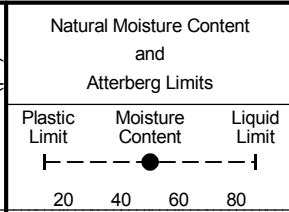

MOISTURE CONTENT (%)	ATTERBERG LIMITS (%)			MINUS #200 SIEVE (%)	OTHER TESTS PERFORMED (Page Ref. #)
	LIQUID LIMIT	PLASTIC LIMIT	PLASTICITY INDEX		
	LL	PL	PI		

Water Level Est.:  Measured:  Perched:   
Water Observations: Dry and open to 20' upon completion and after 30 minutes.

Key to Abbreviations:  
N - SPT Data (Blows/Ft)  
P - Pocket Penetrometer (tsf)  
T - Torvane (tsf)  
L - Lab Vane Shear (tsf)

Notes:  
GPS Coordinates: N 36°15.176', W 94°31.492'



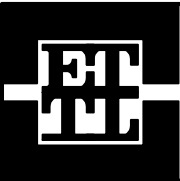

**ETTL  
ENGINEERS &  
CONSULTANTS**

MAIN OFFICE  
1717 East Erwin  
Tyler, Texas 75702  
(903) 595-4421

**LOG OF BORING B-6**

**PROJECT:** Flint Creek Power Plant  
Gentry, Arkansas

**PROJECT NO.:** G3243-09

**BORING TYPE:** Rotary Wash

**DATE** 11/5/09  
**SURFACE ELEVATION** 1141.3

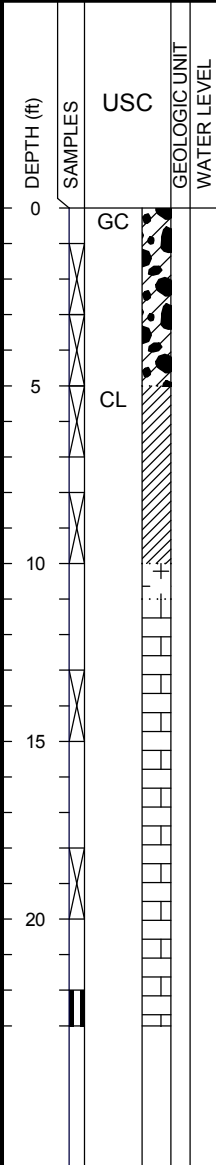

**MATERIAL DESCRIPTION**

CLAYEY GRAVEL (GC) medium dense; red and brown

--red and tan

LEAN CLAY (CL) very stiff; tan and yellow

--hard; red

ROCK ~12" thick layer

LIMESTONE white; with layers of clayey gravel and rock

--RQD<0.25

--RQD<0.25

Bottom of Boring @ 23'  
Refusal @ 23', Core bit broken

FIELD STRENGTH DATA	BLOW COUNT				DRY DENSITY (pcf)	COMPRESSIVE STRENGTH (tsf)	FAILURE STRAIN (%)	CONFINING PRESSURE (psi)	Natural Moisture Content and Atterberg Limits			MOISTURE CONTENT (%)	ATTERBERG LIMITS (%)			MINUS #200 SIEVE (%)	OTHER TESTS PERFORMED (Page Ref. #)
	20	40	60	80					Plastic Limit	Moisture Content	Liquid Limit		LL	PL	PI		
	1	2	3	4													
N=16	●											17	29	24	5	28	+40 Sieve=66%, +4 Sieve=48%
N=15	●																
N=24												17	41	18	23	88	+40 Sieve=2%, +4 Sieve=4%
N=50/2"																	
N=50/2"												55				34	+40 Sieve=59%, +4 Sieve=29%
N=50/1"																	

Water Level Est.: ▽ Measured: ▼ Perched: ▼  
Water Observations: Dry and open upon completion.

Key to Abbreviations:  
N - SPT Data (Blows/Ft)  
P - Pocket Penetrometer (tsf)  
T - Torvane (tsf)  
L - Lab Vane Shear (tsf)

Notes:  
GPS Coordinates: N 36°15.055', W 94°31.458'

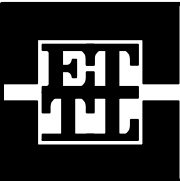

**ETTL  
ENGINEERS &  
CONSULTANTS**

MAIN OFFICE  
1717 East Erwin  
Tyler, Texas 75702  
(903) 595-4421

**LOG OF BORING B-7**

**PROJECT:** Flint Creek Power Plant  
Gentry, Arkansas

**PROJECT NO.:** G3243-09

**BORING TYPE:** Flight Auger

**DATE** 11/6/09  
**SURFACE ELEVATION** 1140.9

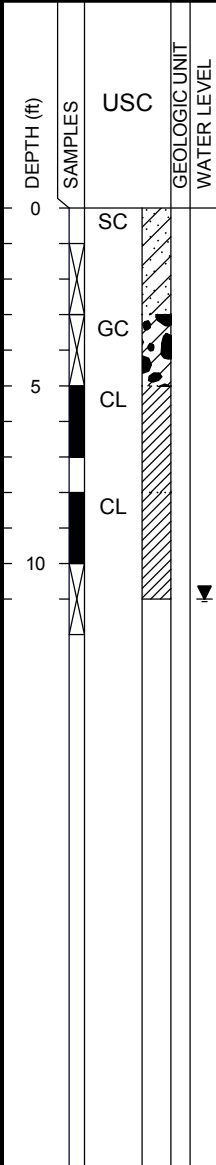

**MATERIAL DESCRIPTION**

CLAYEY SAND(SC) medium dense; tan and brown; with gravel  
CLAYEY GRAVEL(GC) loose; tan and brown  
SANDY LEAN CLAY(CL) stiff; red and tan; with gravel  
LEAN CLAY WITH SAND(CL) gray and tan  
 --limestone rock @ 11'  
 Bottom of Boring @ 11'  
 Refusal @ 11'

FIELD STRENGTH DATA	BLOW COUNT				DRY DENSITY (pcf)	COMPRESSIVE STRENGTH (tsf)	FAILURE STRAIN (%)	CONFINING PRESSURE (psi)	Natural Moisture Content and Atterberg Limits			MOISTURE CONTENT (%)	ATTERBERG LIMITS(%)			OTHER TESTS PERFORMED (Page Ref. #)	
	20	40	60	80					Plastic Limit	Moisture Content	Liquid Limit		LL	PL	PI		MINUS #200 SIEVE (%)
	1	2	3	4													
	PPR (tsf)	Torvane (tsf)															
N=23	●																
N=6	●											14	23	18	5	33	+40 Sieve=63%, +4 Sieve=59%
P=2.0		■															
P=1.5		■															
N=50/2"	●											13	24	15	9	80	+40 Sieve=4%, +4 Sieve=0%

Water Level Est.: Measured: Perched:   
 Water Observations: Seepage @ 11' while drilling. Water level @ 11' and open upon completion.

Key to Abbreviations:  
 N - SPT Data (Blows/Ft)  
 P - Pocket Penetrometer (tsf)  
 T - Torvane (tsf)  
 L - Lab Vane Shear (tsf)

Notes: GPS Coordinates: N 36°14.995', W 94°31.527'

Flint Creek Primary Ash Pond

Low Flow Rates

Total Flowrate = 0.0005(ft<sup>3</sup>/d)/(ft)

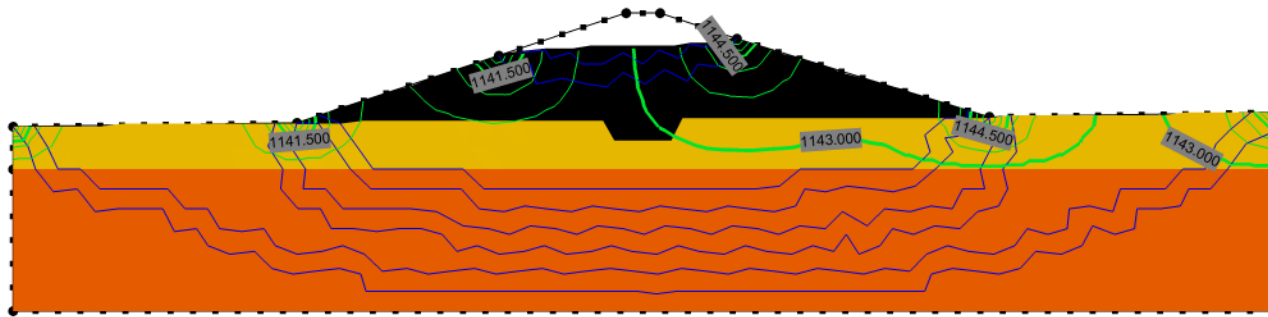

- Materials
- Fill
  - Native Soil
  - Native Rock

Flint Creek Primary Ash Pond

High Flow Rates

Total Flowrate = 0.0046(ft<sup>3</sup>/d)/(ft)

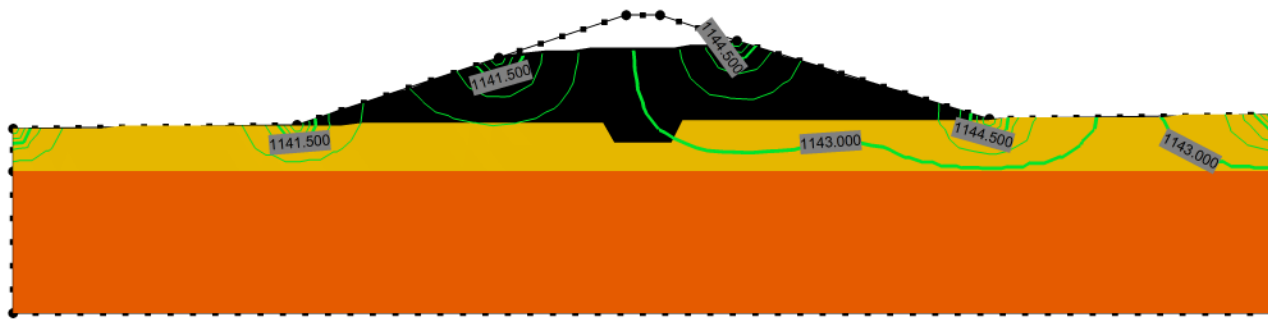

- Materials
- Fill
  - Native Soil
  - Native Rock

Flint Creek Secondary Ash Pond

Low Flow Rates

Total Flowrate = 0.0001(ft<sup>3</sup>/d)/(ft)

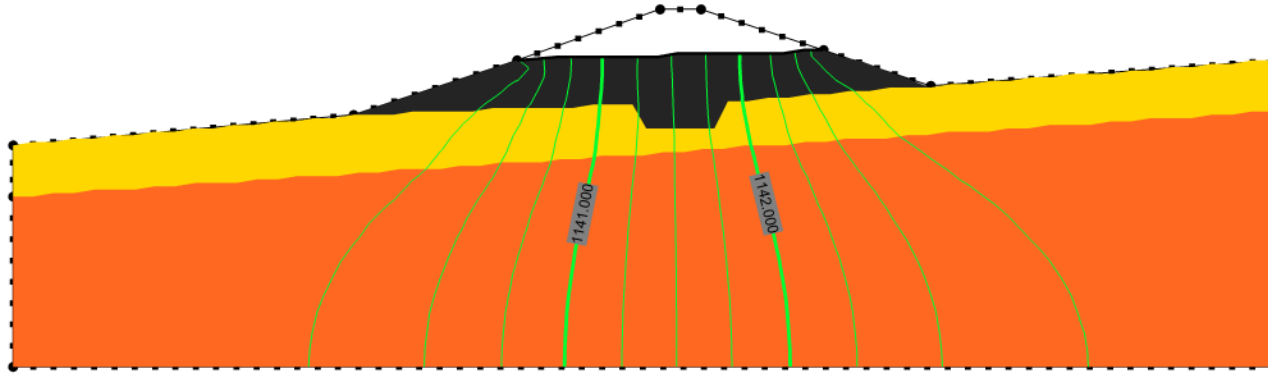

- Materials
- Fill
  - Native Soils
  - Native Rock

Flint Creek Secondary Ash Pond

High Flow Rates

Total Flowrate = 0.0078(ft<sup>3</sup>/d)/(ft)

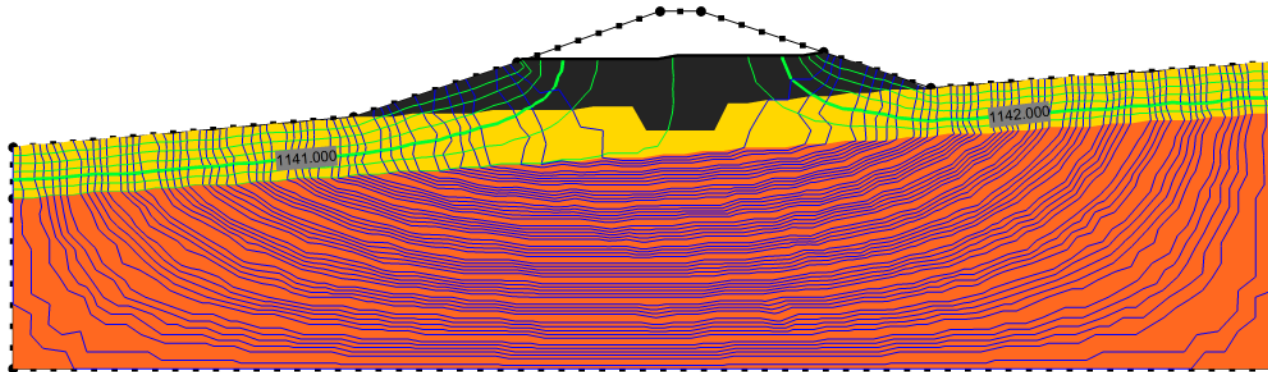

- Materials
- Fill
  - Native Soils
  - Native Rock

# Flint Creek Power Station, Gentry, Arkansas Primary Ash Pond, Steady State with Seismic

S:\GEO\2009\Geo & Civil\Ultimate\1243-09 AEP Flint Creek Power Plant Bottom Ash Ponds Geo Stability Analysis\Slope Stability\Primary SS seismic.in

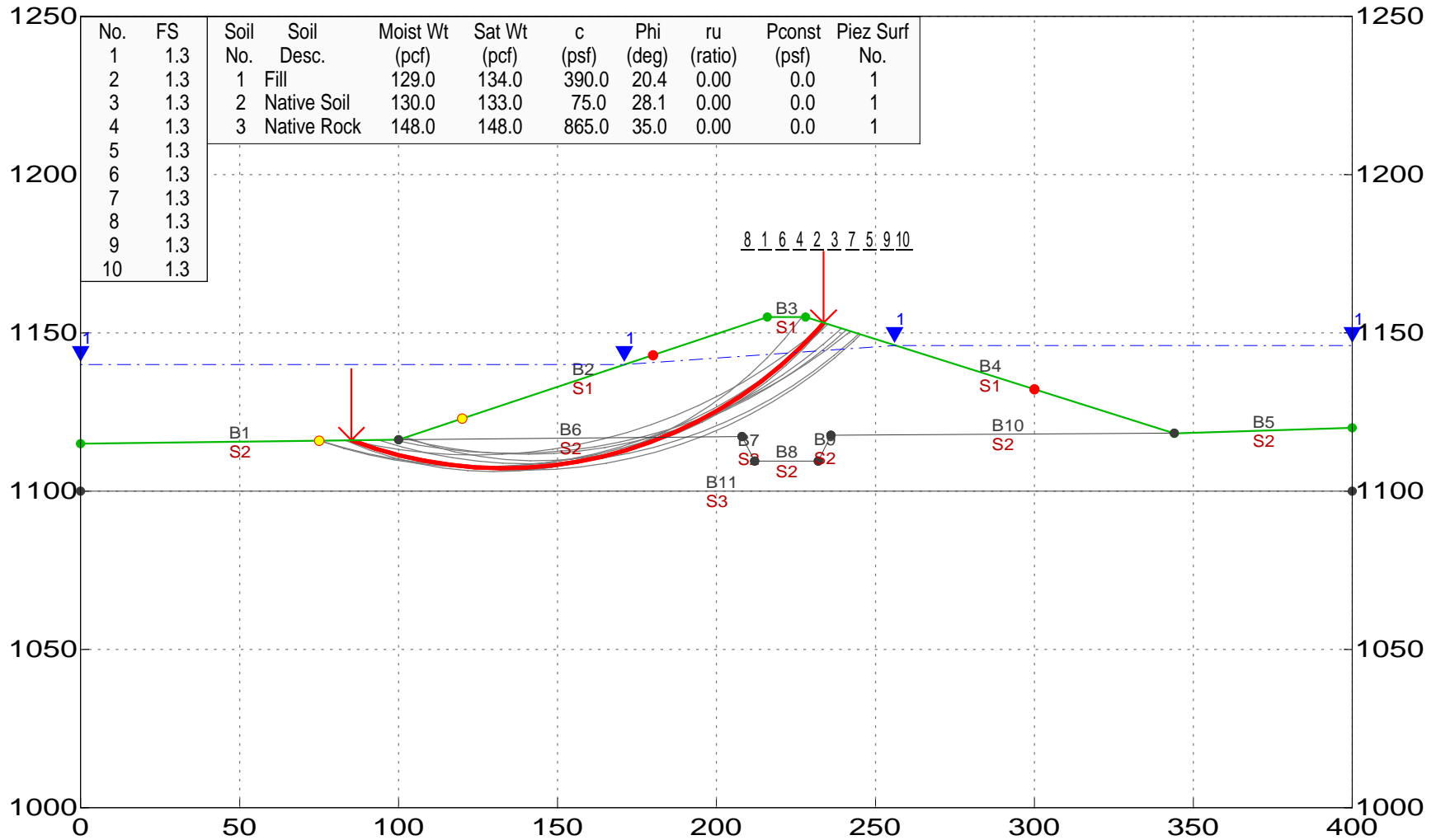

**GEOSTASE FSmin = 1.3**

Modified Bishop Method

# Flint Creek Power Station, Gentry, Arkansas

## Primary Ash Pond, Rapid Drawdown

STC Geotechnical Consultants Inc. Files\3243-09 AEP Flint Creek Power Plant Bottom Ash Ponds Geo Stability Analysis\Slope Stability\Primary RD.in

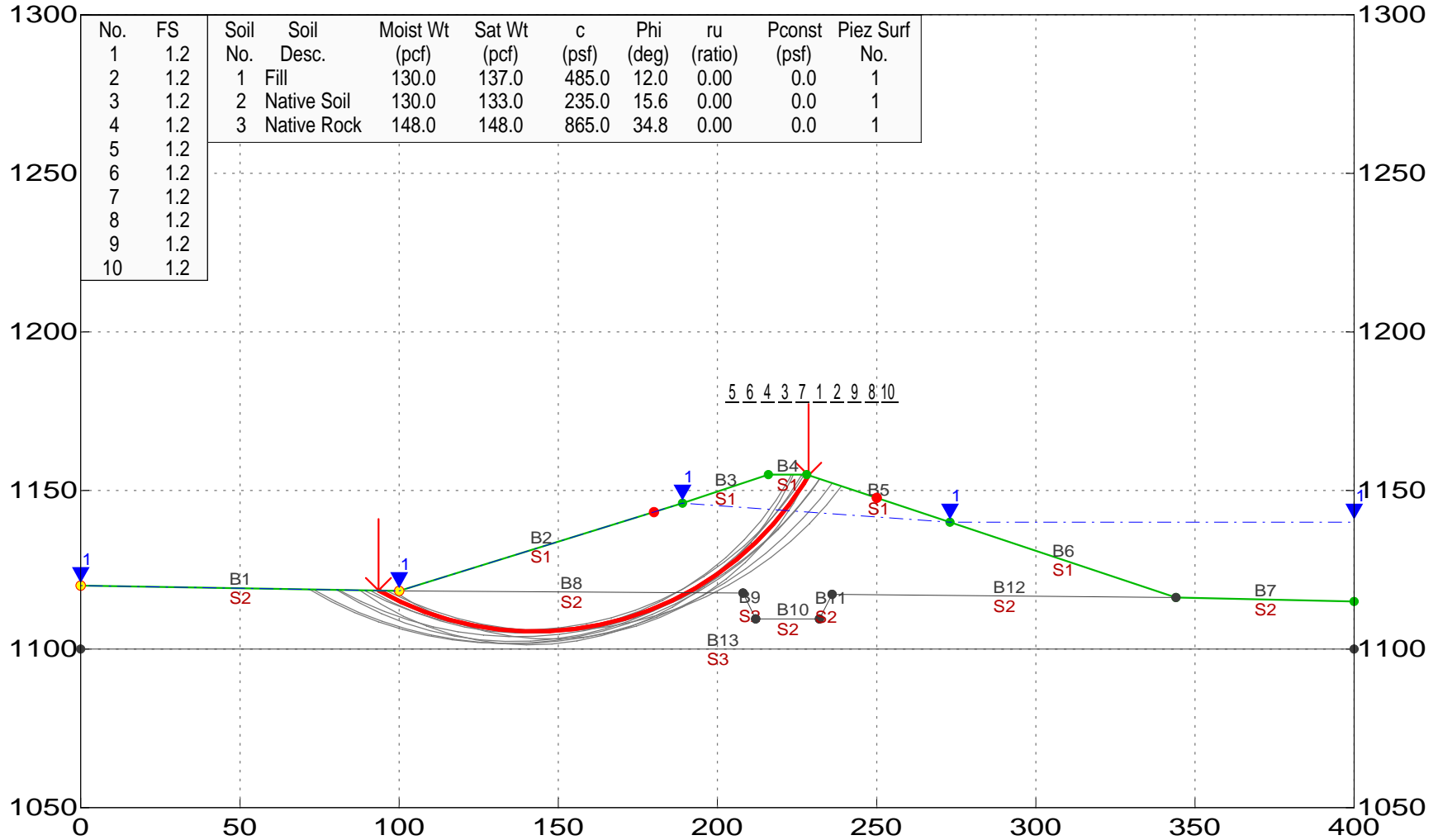

GEOSTASE FSmin = 1.2

Modified Bishop Method



# Flint Creek Power Station, Gentry, Arkansas

## Secondary Ash Pond, Steady State

S:\CADD\2009\Geo\Consult\Jobs\Files\3243-09 AEP Flint Creek Power Plant Bottom Ash Ponds Geo Stability Analysis\Slope Stability\Secondary SS.in

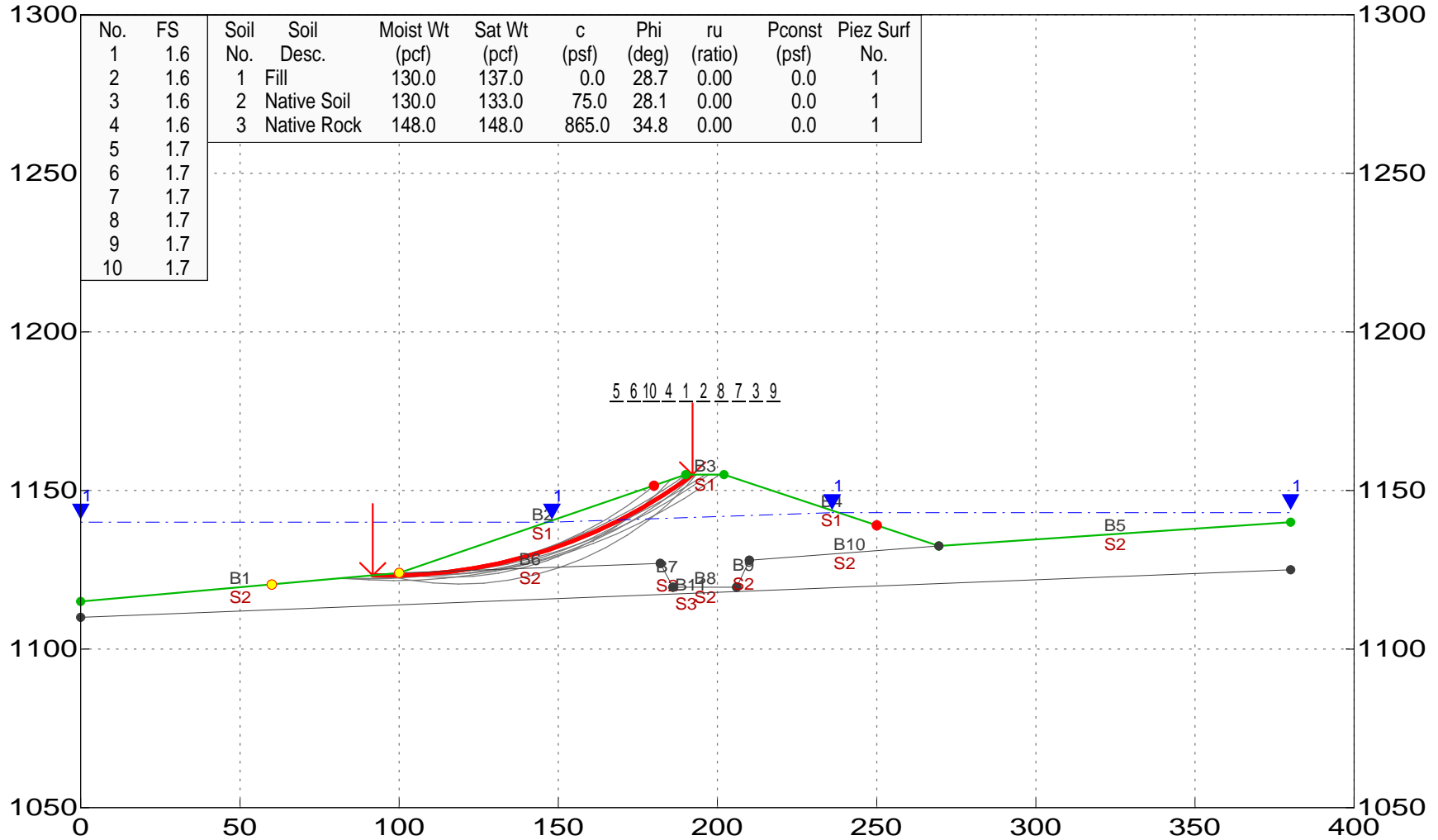

**GEOSTASE FSmin = 1.6**

Modified Bishop Method

# Flint Creek Power Station, Gentry, Arkansas Secondary Ash Pond, Steady State with Seismic

S:\GeoTech\2008-Geo-Consult\111513243-09 AEP Flint Creek Power Plant Bottom Ash Ponds Geo Stability Analysis\Slope Stability\Secondary SS Seismic.in

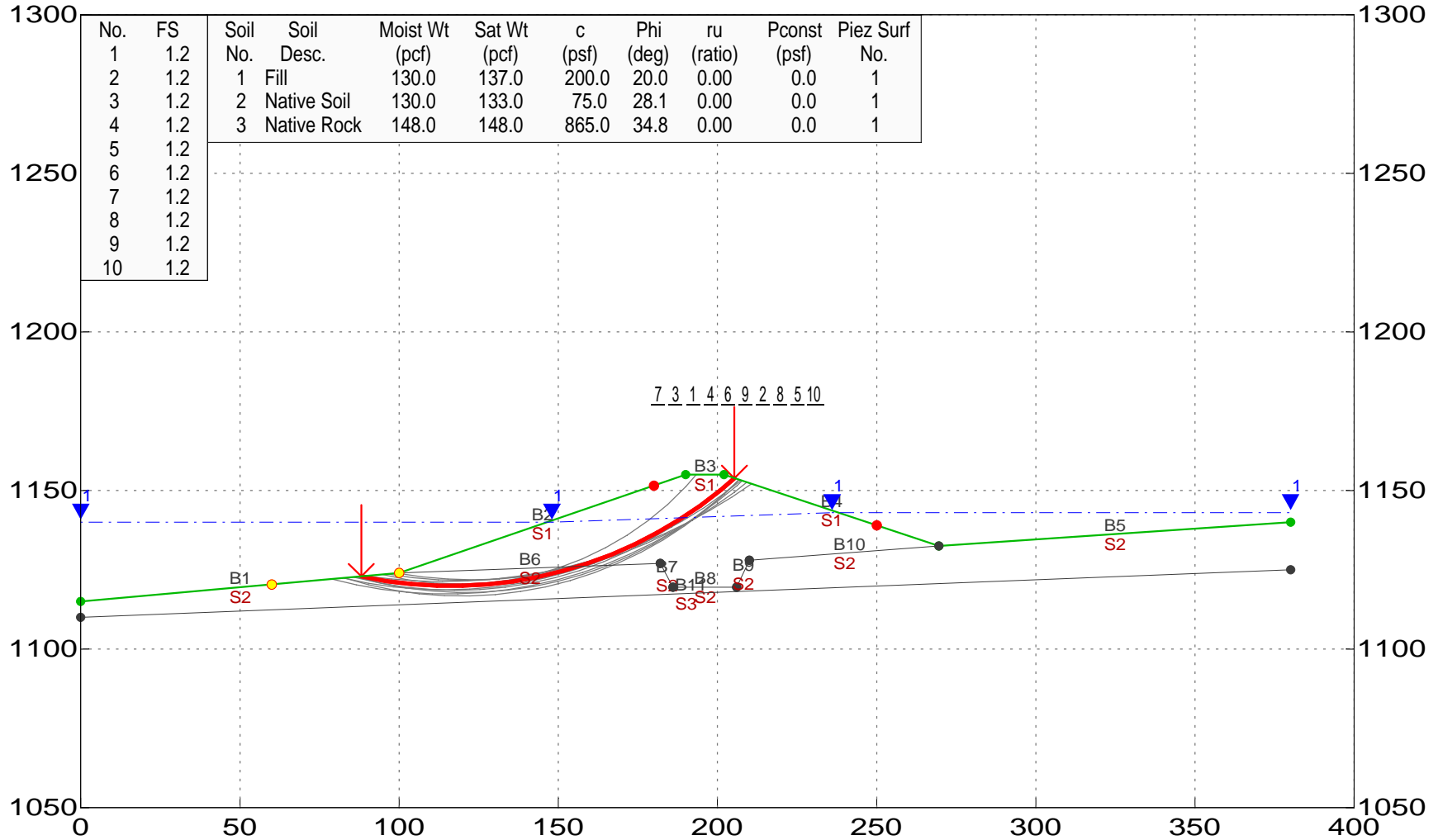

**GEOSTASE FSmin = 1.2**

Modified Bishop Method

# Flint Creek Power Station, Gentry, Arkansas

## Secondary Ash Pond, Rapid Drawdown

S:\CET\2009\Geo & Const\013243-09 AEP Flint Creek Power Plant Bottom Ash Ponds Geo Stability Analysis\Slope Stability\Secondary RD.in

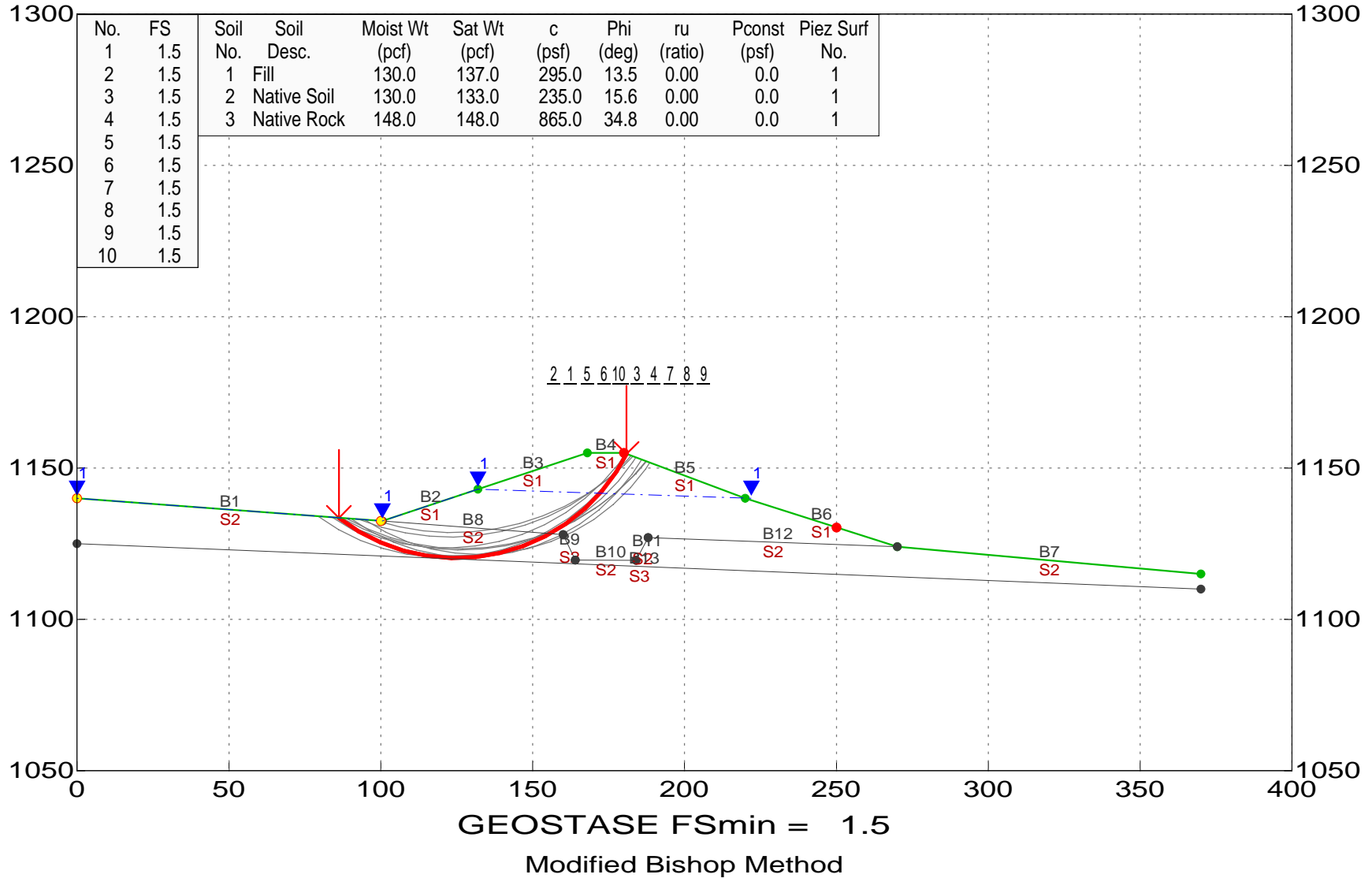

### PROJECT INFORMATION

PROJECT: Flint Creek Power Plant  
LOCATION: Centry, AR  
PROJECT NO: G 3243 - 09  
CLIENT: AEP  
December 2009

### TRIAxIAL TEST PROGRAM BY GARRY H. GREGORY, P.E.

ALL RIGHTS RESERVED - UNAUTHORIZED USE PROHIBITED  
VERSION 1.0 - AUGUST 1998 - REVISED MARCH 24, 1999

THIS COPY LICENSED TO:  
ETTL ENGINEERS AND CONSULTANTS, INC.  
1717 East Erwin  
Tyler, TX 75702

### TEST DESCRIPTION

TYPE OF TEST & NO: CU with PP  
SAMPLE TYPE: Shelby Tube Sample  
DESCRIPTION: Redd. Brown & Tan & Gray Fat Clay w/ Gravel  
Sampled on Site, B-2 3' to 7' deep  
ASSUMED SPECIFIC GRAVITY: 2.7 + 40 Sieve  
LL: PL: PI: Percent -200:  
REMARKS: Diameter and Both Ends Trimmed + # 4 Sieve

PLATE: B.1

PLATE: B.2

PLATE: B.3

Number of Specimens = 3

# TRIAxIAL SHEAR TEST REPORT

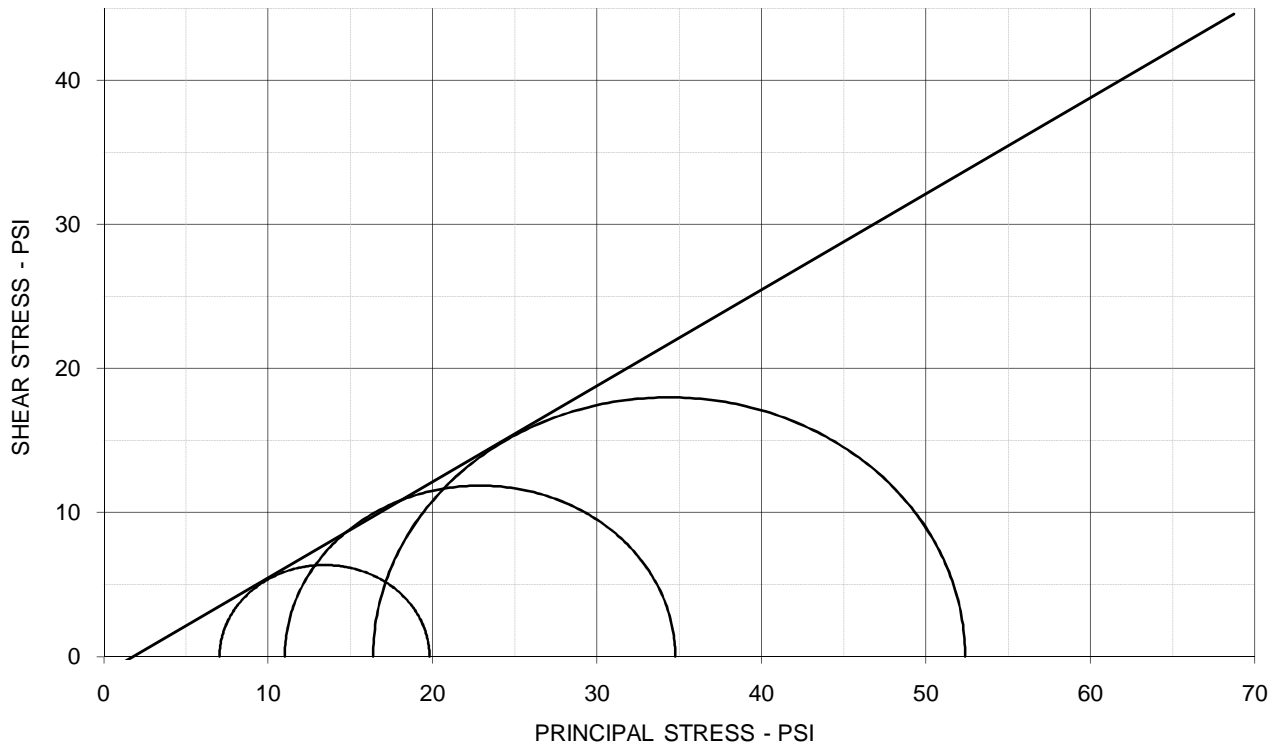

## EFFECTIVE STRESS PARAMETERS

$\phi' = 33.7 \text{ deg}$        $c' = -1.2 \text{ psi}$

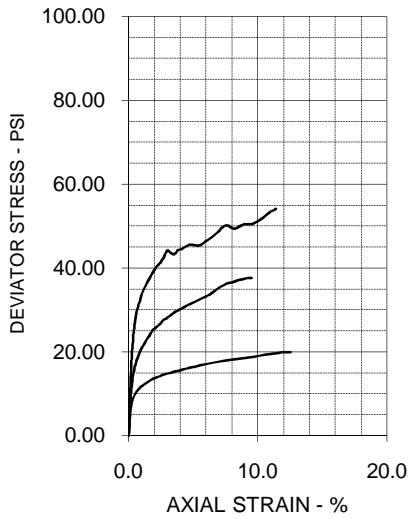

SPECIMEN NO.	1	2	3	4
INITIAL				
Moisture Content - %	16.9	15.1	21.1	
Dry Density - pcf	108.9	113.4	107.0	
Diameter - inches	2.79	2.75	2.76	
Height - inches	5.68	4.33	5.19	
AT TEST				
Final Moisture - %	21.7	19.9	19.4	
Dry Density - pcf	109.4	114.8	109.2	
Calculated Diameter (in.)	2.79	2.74	2.73	
Height - inches	5.68	4.28	5.12	
Effect. Cell Pressure - psi	10.0	20.0	40.0	
Failure Stress - psi	12.74	23.73	35.99	
Total Pore Pressure - psi	62.9	59.0	73.6	
Strain Rate - inches/min.	0.00050	0.00050	0.00050	
Failure Strain - %	1.5	1.6	1.4	
$\sigma_1'$ Failure - psi	19.80	34.74	52.37	
$\sigma_3'$ Failure - psi	7.06	11.01	16.38	

## TEST DESCRIPTION

## PROJECT INFORMATION

TYPE OF TEST & NO: CU with PP  
 SAMPLE TYPE: Shelby Tube Sample  
 DESCRIPTION: Redd. Brown & Tan & Gray Fat Clay w/ Gravel  
 Sampled on Site, B-2 3' to 7' deep  
 ASSUMED SPECIFIC GRAVITY: 2.7 + 40 Sieve  
 LL:      PL:      PI:      Percent -200:  
 REMARKS: Diameter and Both Ends Trimmed + # 4 Sieve  
 G 3243 09, B 2 3' 7' Flint Creek

PROJECT: Flint Creek Power Plant  
 LOCATION: Centry, AR  
 PROJECT NO: G 3243 - 09  
 CLIENT: AEP  
 December 2009

**ETTL ENGINEERS & CONSULTANTS**

**PLATE: B.1**

SPECIMEN NO. 1

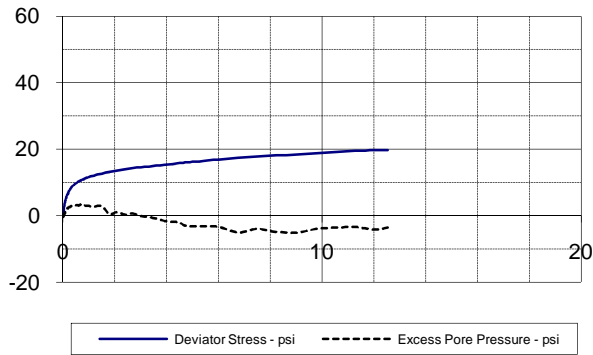

SPECIMEN NO. 2

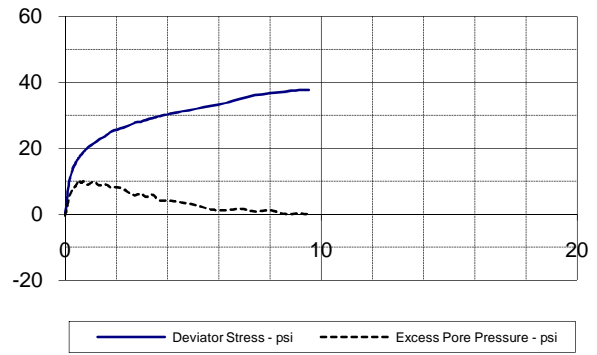

SPECIMEN NO. 3

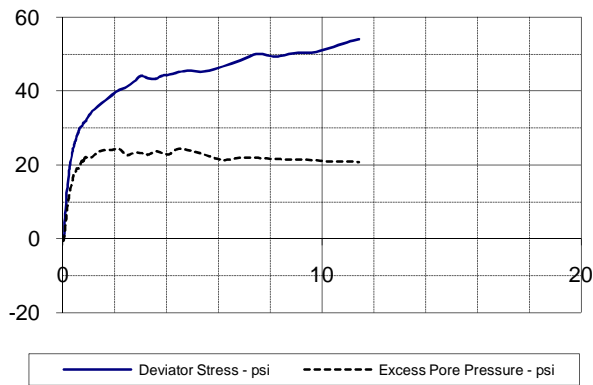

SPECIMEN NO. 4

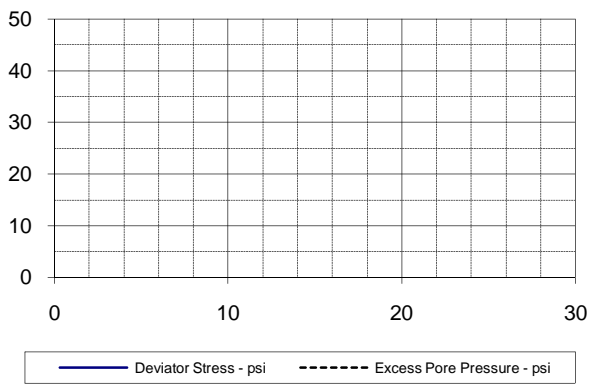

p - q DIAGRAM

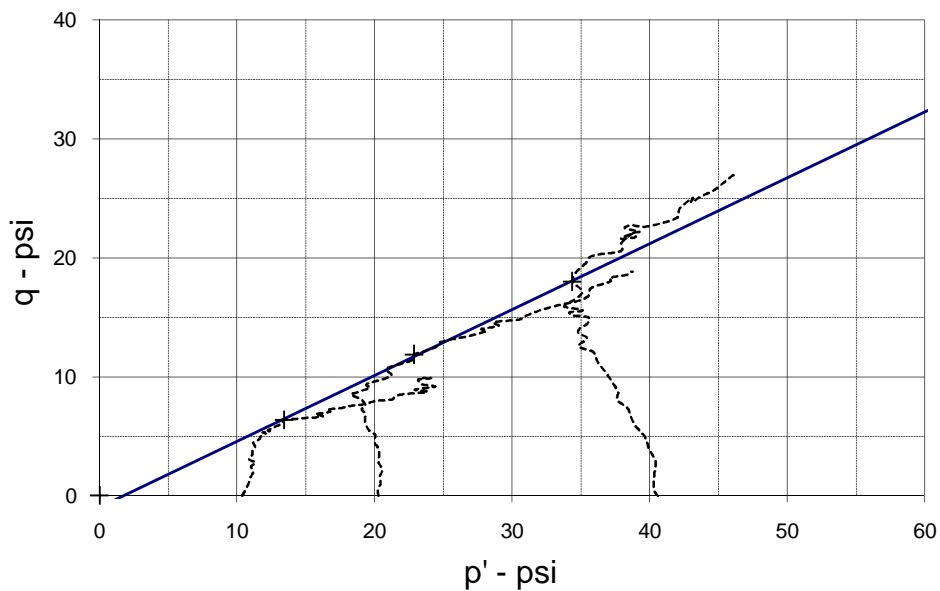

EFFECTIVE STRESS PARAMETERS	$R^2 = 1.00$	$\alpha$ (deg) = 29.0	a (psi) = -1.0
PROJECT: Flint Creek Power Plant	TYPE OF TEST & NO: CU with PP		
PROJECT NO: G 3243 - 09	E TTL ENGINEERS & CONSULTANTS	PLATE: B.2	
DESCRIPTION: Redd. Brown & Tan & Gray Fat Clay w/ Gravel			

# TRIAXIAL SHEAR TEST REPORT

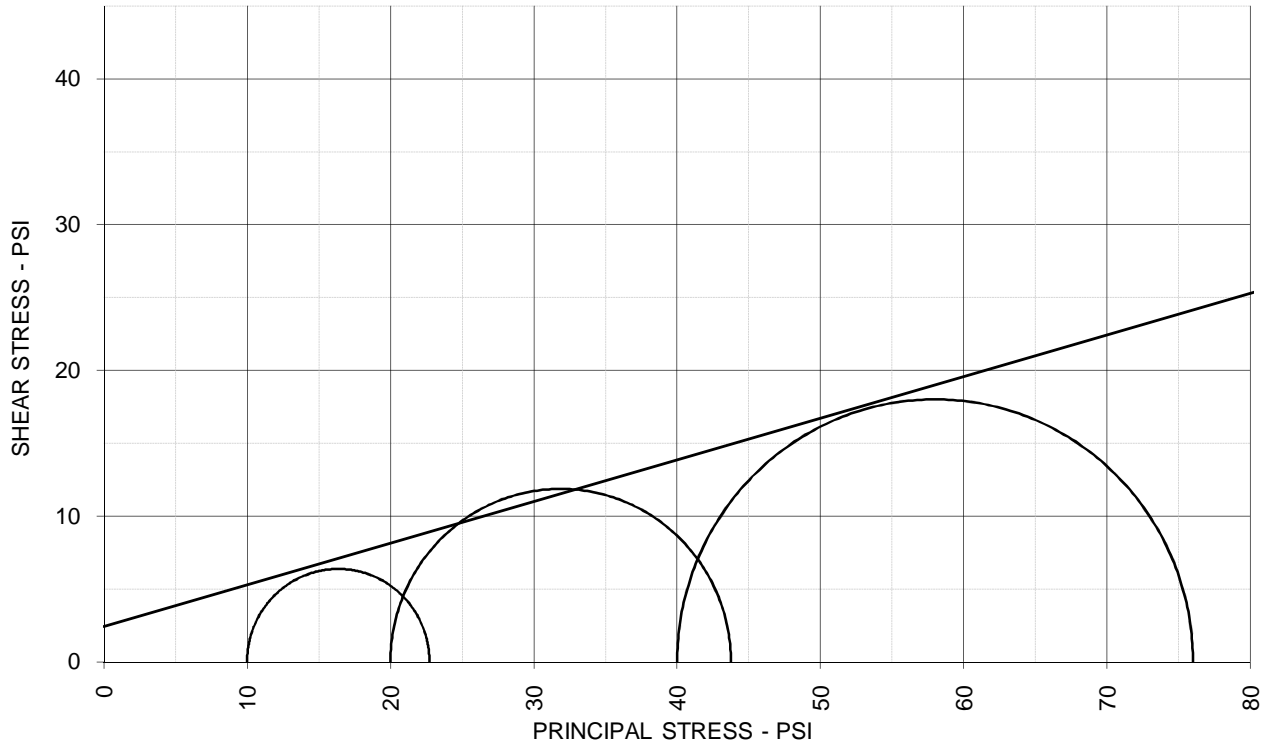

## TOTAL STRESS PARAMETERS

$\phi = 15.9 \text{ deg}$

$c = 2.4 \text{ psi}$

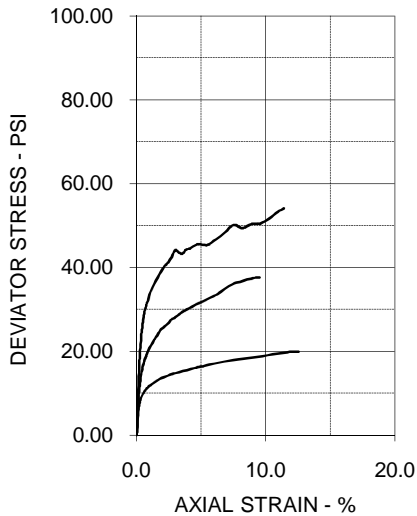

## SPECIMEN NO.

1      2      3      4

### INITIAL

Moisture Content - %	16.9	15.1	21.1
Dry Density - pcf	108.9	113.4	107.0
Diameter - inches	2.79	2.75	2.76
Height - inches	5.68	4.33	5.19

### AT TEST

Final Moisture - %	21.7	19.9	19.4
Dry Density - pcf	109.4	114.8	109.2
Calculated Diameter (in.)	2.79	2.74	2.73
Height - inches	5.68	4.28	5.12
Effect. Cell Pressure - psi	10.0	20.0	40.0
Failure Stress - psi	12.74	23.73	35.99
Total Pore Pressure - psi	62.9	59.0	73.6
Strain Rate - inches/min.	0.00050	0.00050	0.00050
Failure Strain - %	1.5	1.6	1.4
$\sigma_1$ Failure - psi	22.74	43.73	75.99
$\sigma_3$ Failure - psi	10.00	20.00	40.00

## TEST DESCRIPTION

TYPE OF TEST & NO: CU with PP  
 SAMPLE TYPE: Shelby Tube Sample  
 DESCRIPTION: Redd. Brown & Tan & Gray Fat Clay w/ Gravel  
 Sampled on Site, B-2 3' to 7' deep  
 ASSUMED SPECIFIC GRAVITY: 2.7 + 40 Sieve  
 LL:      PL:      PI:      Percent -200:  
 REMARKS: Diameter and Both Ends Trimmed + # 4 Sieve

## PROJECT INFORMATION

PROJECT: Flint Creek Power Plant  
 LOCATION: Centry, AR  
 PROJECT NO: G 3243 - 09  
 CLIENT: AEP  
 December 2009

ETTL ENGINEERS & CONSULTANTS

PLATE: B.3

### PROJECT INFORMATION

PROJECT: Flint Creek Power Plant  
LOCATION: Centry, AR  
PROJECT NO: G 3243 - 09  
CLIENT: AEP  
December 2009

### TRIAxIAL TEST PROGRAM BY GARRY H. GREGORY, P.E.

ALL RIGHTS RESERVED - UNAUTHORIZED USE PROHIBITED  
VERSION 1.0 - AUGUST 1998 - REVISED MARCH 24, 1999

THIS COPY LICENSED TO:  
ETTL ENGINEERS AND CONSULTANTS, INC.  
1717 East Erwin  
Tyler, TX 75702

### TEST DESCRIPTION

TYPE OF TEST & NO: CU with PP  
SAMPLE TYPE: Shelby Tube Sample  
DESCRIPTION: Reddish Brown & Tan Lean Clay  
Sampled on Site, B-2 23' to 35' deep  
ASSUMED SPECIFIC GRAVITY: 2.7 + 40 Sieve  
LL: PL: PI: Percent -200:  
REMARKS: Diameter and Both Ends Trimmed + # 4 Sieve

PLATE: B.1

PLATE: B.2

PLATE: B.3

Number of Specimens = 3



## TRIAxIAL SHEAR TEST REPORT

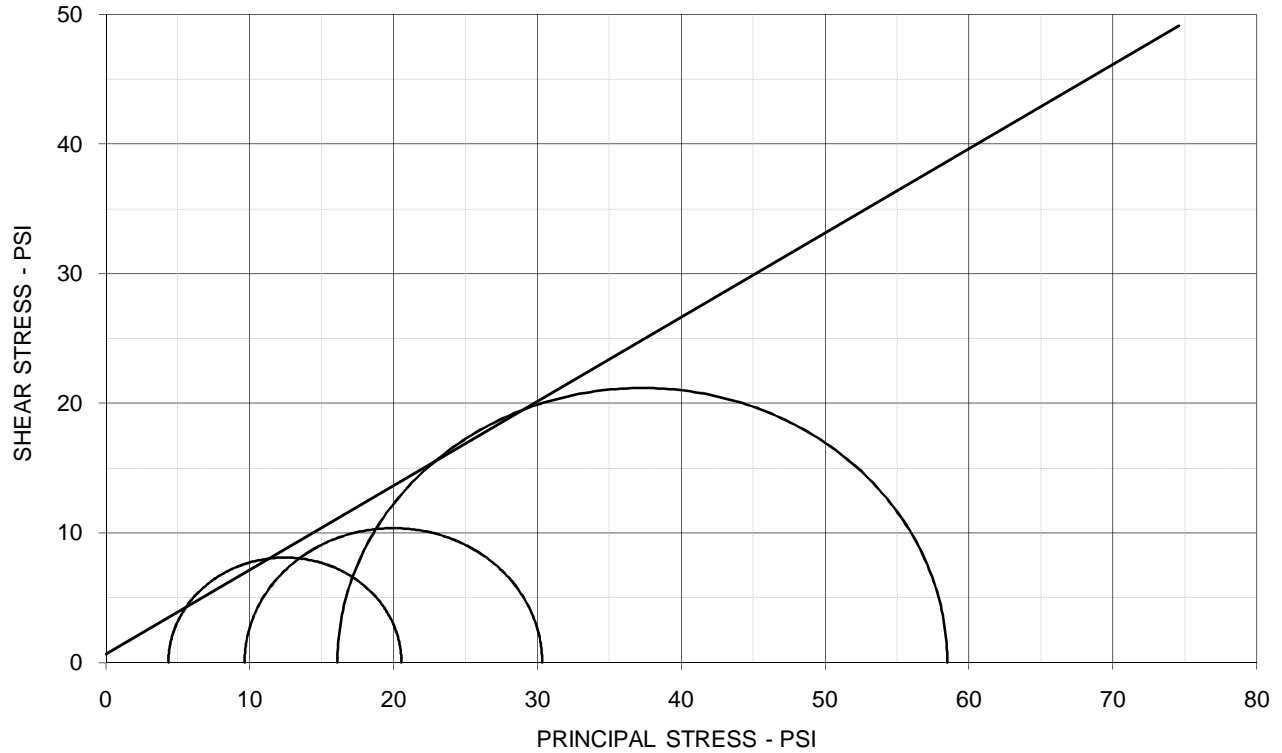

### EFFECTIVE STRESS PARAMETERS

$\phi' = 33.0 \text{ deg}$

$c' = 0.6 \text{ psi}$

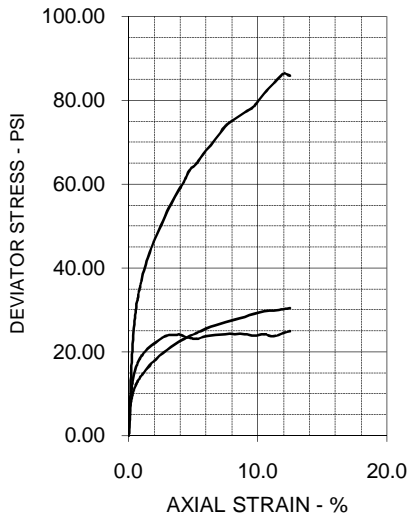

SPECIMEN NO.	1	2	3	4
INITIAL				
Moisture Content - %	21.8	20.0	17.7	
Dry Density - pcf	103.5	109.2	114.4	
Diameter - inches	2.78	2.76	2.80	
Height - inches	5.68	5.67	5.69	
AT TEST				
Final Moisture - %	23.5	21.0	16.6	
Dry Density - pcf	103.8	110.3	117.0	
Calculated Diameter (in.)	2.77	2.74	2.78	
Height - inches	5.65	5.63	5.64	
Effect. Cell Pressure - psi	10.0	20.0	40.0	
Failure Stress - psi	16.18	20.70	42.40	
Total Pore Pressure - psi	55.6	60.4	73.9	
Strain Rate - inches/min.	0.00050	0.00050	0.00050	
Failure Strain - %	1.5	1.5	1.5	
$\sigma_1'$ Failure - psi	20.55	30.34	58.49	
$\sigma_3'$ Failure - psi	4.37	9.64	16.09	

### TEST DESCRIPTION

### PROJECT INFORMATION

TYPE OF TEST & NO: CU with PP  
 SAMPLE TYPE: Shelby Tube Sample  
 DESCRIPTION: Reddish Brown & Tan Lean Clay  
 Sampled on Site, B-2 23' to 35' deep  
 ASSUMED SPECIFIC GRAVITY: 2.7 + 40 Sieve  
 LL:            PL:            PI:            Percent -200:  
 REMARKS: Diameter and Both Ends Trimmed + # 4 Sieve  
 G 3243-09, B 2 23' 35' Flint Creek

PROJECT: Flint Creek Power Plant  
 LOCATION: Centry, AR  
 PROJECT NO: G 3243 - 09  
 CLIENT: AEP  
 December 2009

ETTL ENGINEERS & CONSULTANTS

PLATE: B.1

SPECIMEN NO. 1

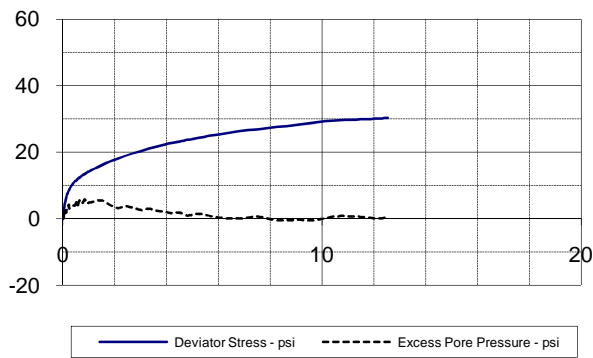

SPECIMEN NO. 2



SPECIMEN NO. 3

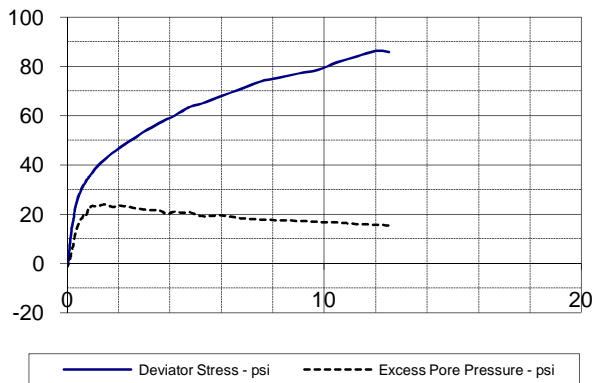

SPECIMEN NO. 4

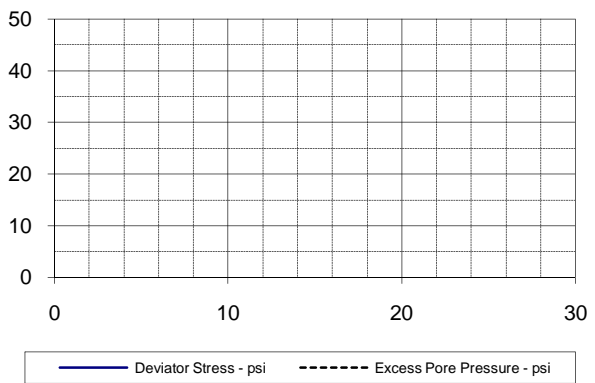

p - q DIAGRAM

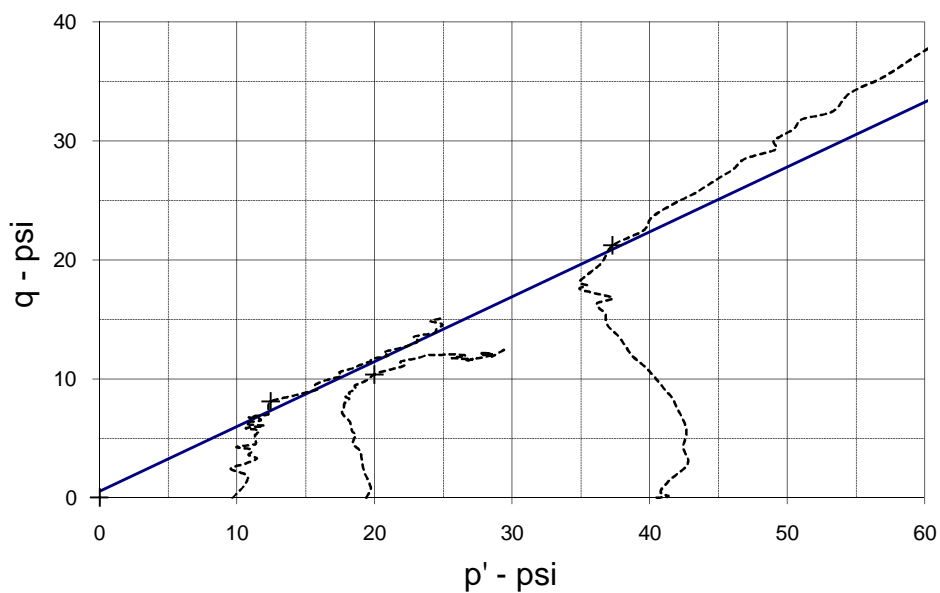

EFFECTIVE STRESS PARAMETERS	$R^2 = 0.98$	$\alpha$ (deg) = 28.6	$a$ (psi) = 0.5
PROJECT: Flint Creek Power Plant	TYPE OF TEST & NO: CU with PP		
PROJECT NO: G 3243 - 09	ETTL ENGINEERS & CONSULTANTS		PLATE: B.2
DESCRIPTION: Reddish Brown & Tan Lean Clay			

G 3243-09, B-2 23'-35' Flint Creek

# TRIAXIAL SHEAR TEST REPORT

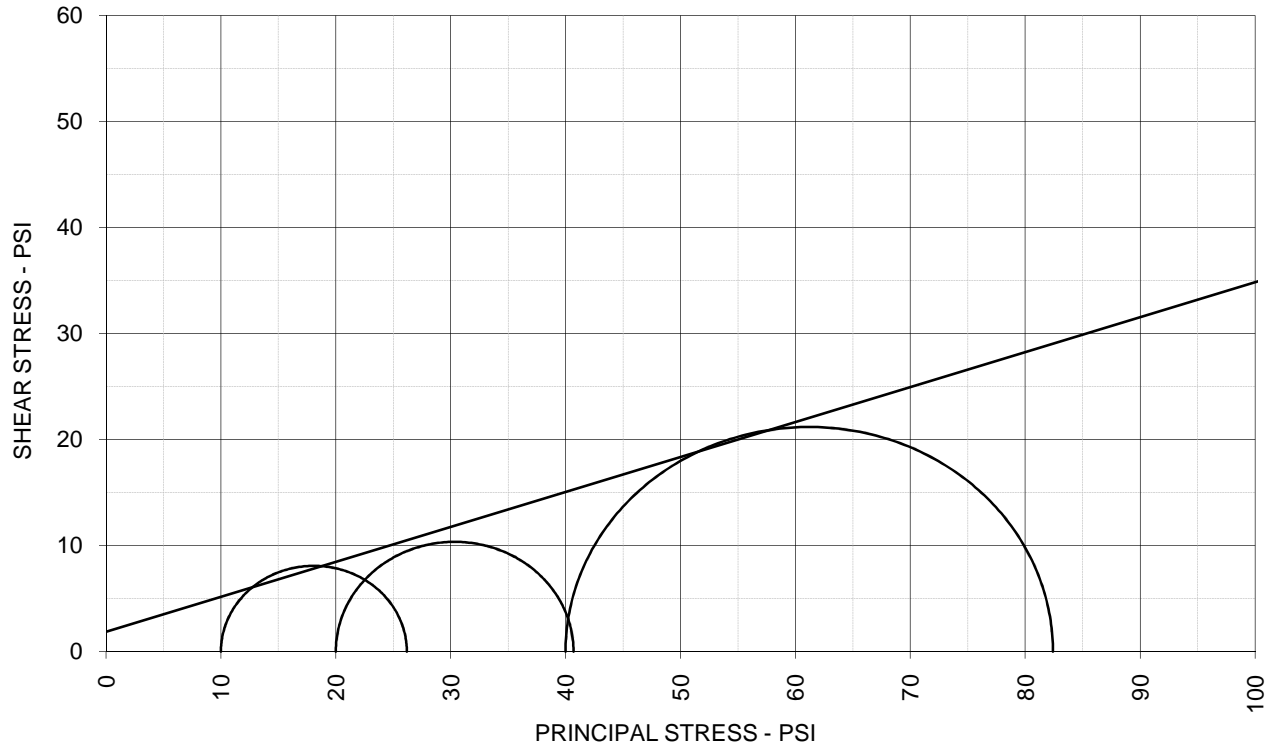

## TOTAL STRESS PARAMETERS

$\phi = 18.3 \text{ deg}$

$c = 1.9 \text{ psi}$

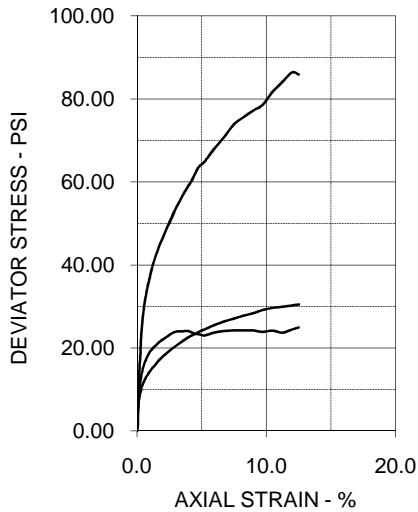

SPECIMEN NO.	1	2	3	4
INITIAL				
Moisture Content - %	21.8	20.0	17.7	
Dry Density - pcf	103.5	109.2	114.4	
Diameter - inches	2.78	2.76	2.80	
Height - inches	5.68	5.67	5.69	
AT TEST				
Final Moisture - %	23.5	21.0	16.6	
Dry Density - pcf	103.8	110.3	117.0	
Calculated Diameter (in.)	2.77	2.74	2.78	
Height - inches	5.65	5.63	5.64	
Effect. Cell Pressure - psi	10.0	20.0	40.0	
Failure Stress - psi	16.18	20.70	42.40	
Total Pore Pressure - psi	55.6	60.4	73.9	
Strain Rate - inches/min.	0.00050	0.00050	0.00050	
Failure Strain - %	1.5	1.5	1.5	
$\sigma_1$ Failure - psi	26.18	40.70	82.40	
$\sigma_3$ Failure - psi	10.00	20.00	40.00	

## TEST DESCRIPTION

TYPE OF TEST & NO: CU with PP  
 SAMPLE TYPE: Shelby Tube Sample  
 DESCRIPTION: Reddish Brown & Tan Lean Clay  
 Sampled on Site, B-2 23' to 35' deep  
 ASSUMED SPECIFIC GRAVITY: 2.7 + 40 Sieve  
 LL: PL: PI: Percent -200:  
 REMARKS: Diameter and Both Ends Trimmed + # 4 Sieve

## PROJECT INFORMATION

PROJECT: Flint Creek Power Plant  
 LOCATION: Centry, AR  
 PROJECT NO: G 3243 - 09  
 CLIENT: AEP  
 December 2009

ETTL ENGINEERS & CONSULTANTS

PLATE: B.3

### PROJECT INFORMATION

PROJECT: Flint Creek Power Plant  
LOCATION: Centry, AR  
PROJECT NO: G 3243 - 09  
CLIENT: AEP  
December 2009

### TRIAxIAL TEST PROGRAM BY GARRY H. GREGORY, P.E.

ALL RIGHTS RESERVED - UNAUTHORIZED USE PROHIBITED  
VERSION 1.0 - AUGUST 1998 - REVISED MARCH 24, 1999

THIS COPY LICENSED TO:  
ETTL ENGINEERS AND CONSULTANTS, INC.  
1717 East Erwin  
Tyler, TX 75702

### TEST DESCRIPTION

TYPE OF TEST & NO: CU with PP  
SAMPLE TYPE: Shelby Tube Sample  
DESCRIPTION: Redd. Brown & Tan Sandy Lean Clay w/ Gravel  
Sampled on Site, B-3 3' to 7' deep  
ASSUMED SPECIFIC GRAVITY: 2.7 + 40 Sieve  
LL: PL: PI: Percent -200:  
REMARKS: Diameter and Both Ends Trimmed + # 4 Sieve

PLATE: B.1

PLATE: B.2

PLATE: B.3

Number of Specimens = 3

## TRIAxIAL SHEAR TEST REPORT

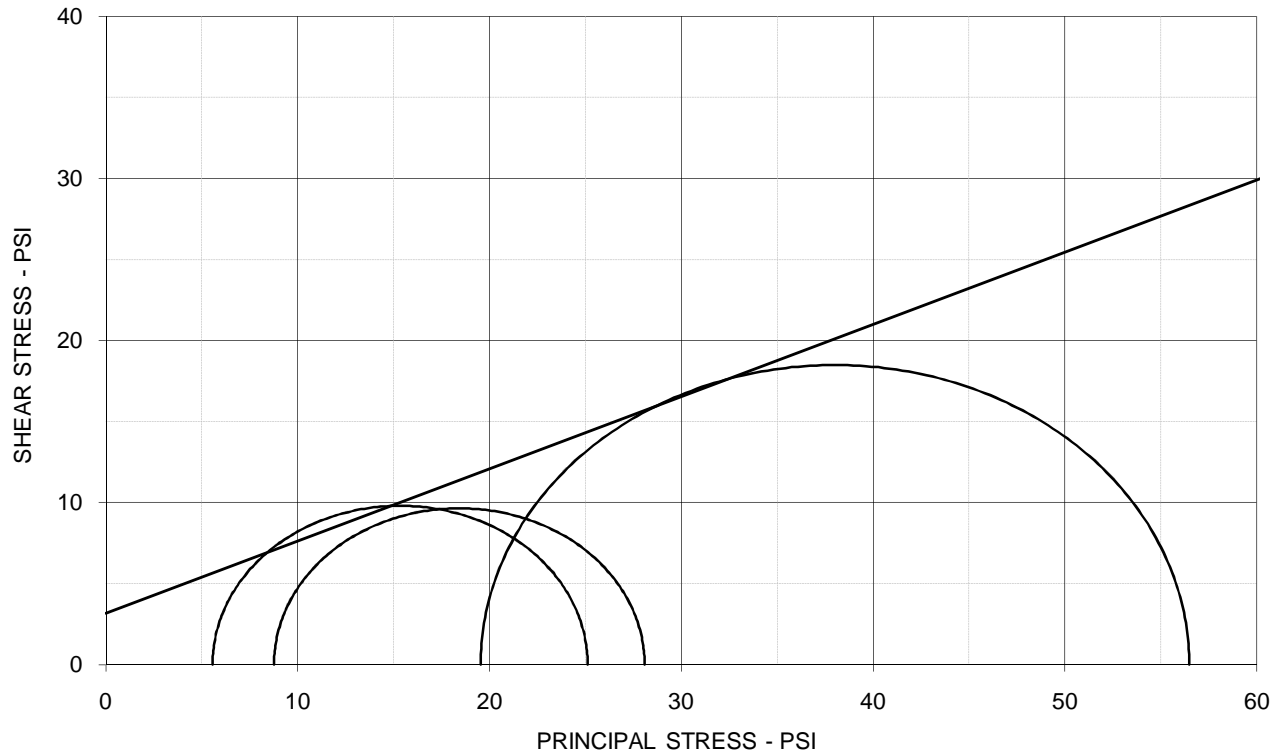

### EFFECTIVE STRESS PARAMETERS

$\phi' = 24.0 \text{ deg}$

$c' = 3.2 \text{ psi}$

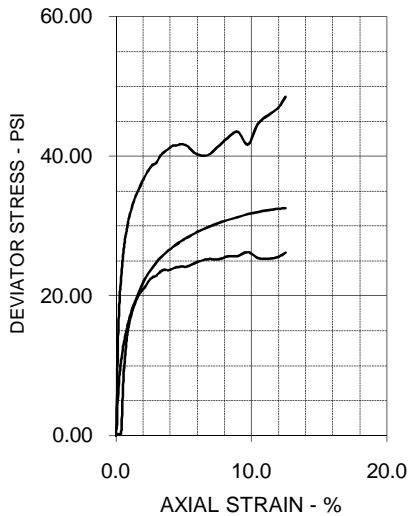

SPECIMEN NO.	1	2	3	4
INITIAL				
Moisture Content - %	17.6	20.3	17.6	
Dry Density - pcf	107.9	106.2	107.7	
Diameter - inches	2.76	2.76	2.77	
Height - inches	5.68	5.68	5.68	
AT TEST				
Final Moisture - %	24.0	22.3	22.0	
Dry Density - pcf	108.5	107.0	109.8	
Calculated Diameter (in.)	2.76	2.75	2.75	
Height - inches	5.67	5.64	5.62	
Effect. Cell Pressure - psi	10.0	20.0	40.0	
Failure Stress - psi	19.56	19.31	36.95	
Total Pore Pressure - psi	54.4	61.2	70.5	
Strain Rate - inches/min.	0.00050	0.00050	0.00050	
Failure Strain - %	1.5	1.5	2.1	
$\sigma_1'$ Failure - psi	25.12	28.08	56.49	
$\sigma_3'$ Failure - psi	5.56	8.77	19.54	

### TEST DESCRIPTION

### PROJECT INFORMATION

TYPE OF TEST & NO: CU with PP  
 SAMPLE TYPE: Shelby Tube Sample  
 DESCRIPTION: Redd. Brown & Tan Sandy Lean Clay w/ Gravel  
 Sampled on Site, B-3 3' to 7' deep  
 ASSUMED SPECIFIC GRAVITY: 2.7 + 40 Sieve  
 LL:            PL:            PI:            Percent -200:  
 REMARKS: Diameter and Both Ends Trimmed + # 4 Sieve  
 G 3243-09, B 3 5' 7" Flint Creek

PROJECT: Flint Creek Power Plant  
 LOCATION: Centry, AR  
 PROJECT NO: G 3243 - 09  
 CLIENT: AEP  
 December 2009

**ETTL ENGINEERS & CONSULTANTS**

**PLATE: B.1**

SPECIMEN NO. 1

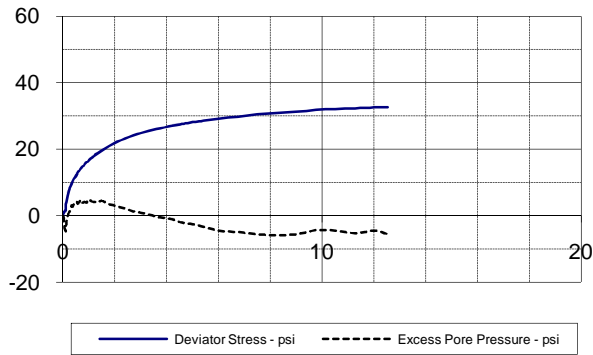

SPECIMEN NO. 2

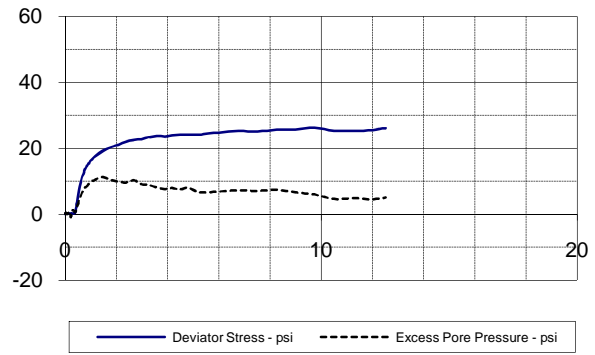

SPECIMEN NO. 3

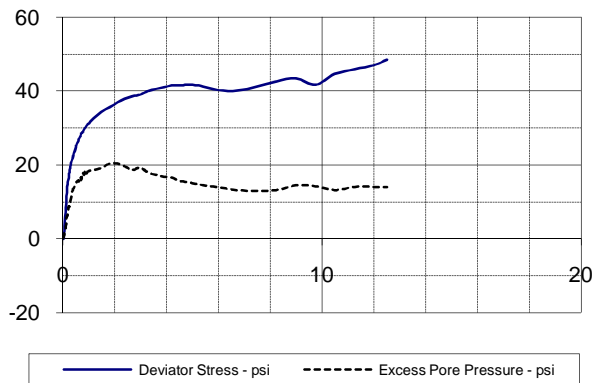

SPECIMEN NO. 4

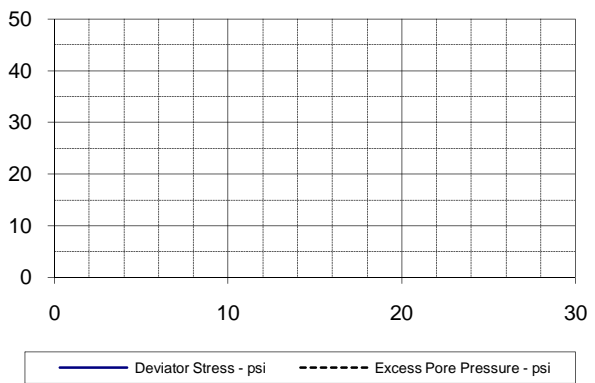

p - q DIAGRAM

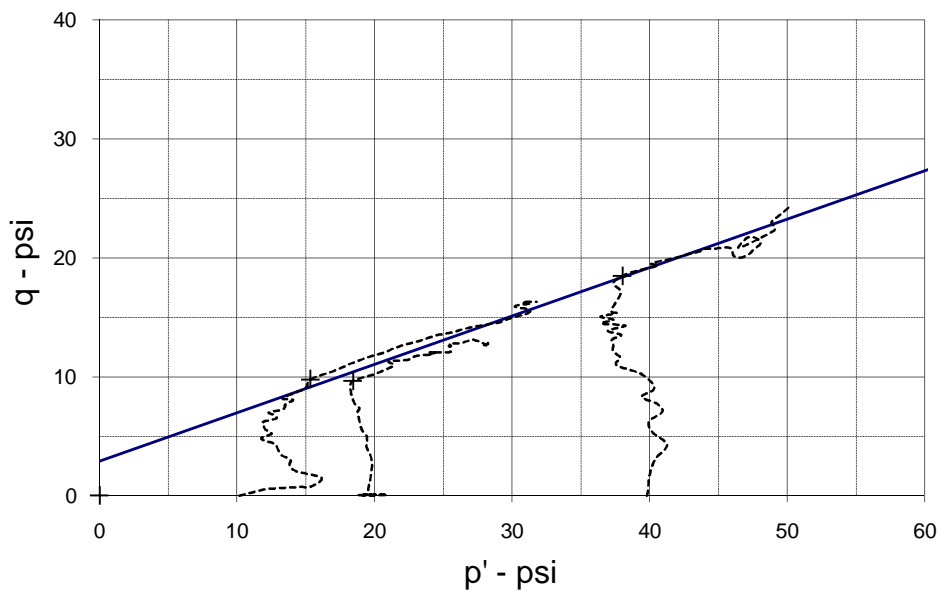

EFFECTIVE STRESS PARAMETERS	$R^2 = 0.98$	$\alpha$ (deg) = 22.2	a (psi) = 2.9
PROJECT: Flint Creek Power Plant	TYPE OF TEST & NO: CU with PP		
PROJECT NO: G 3243 - 09	ETTL ENGINEERS & CONSULTANTS		PLATE: B.2
DESCRIPTION: Redd. Brown & Tan Sandy Lean Clay w/ Gravel			

G 3243-09, B-3 5'-7' Flint Creek

# TRIAXIAL SHEAR TEST REPORT

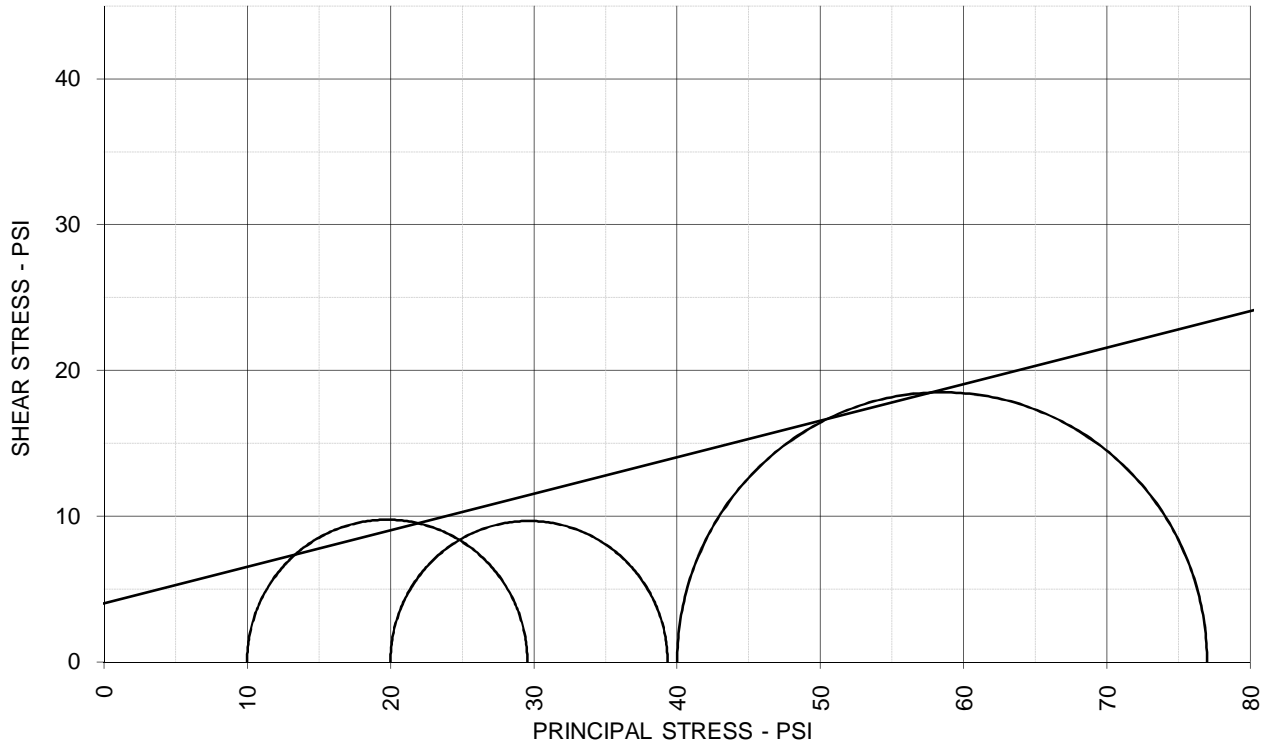

### TOTAL STRESS PARAMETERS

$\phi = 14.1 \text{ deg}$

$c = 4.0 \text{ psi}$

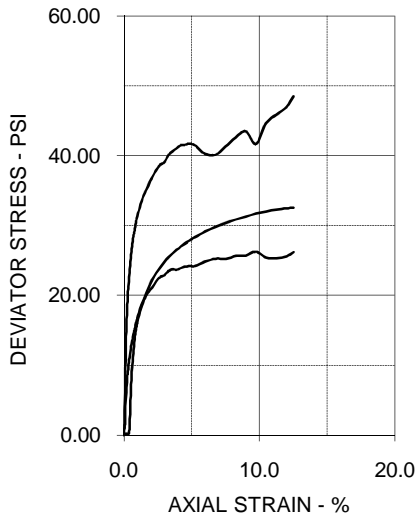

SPECIMEN NO.	1	2	3	4
INITIAL				
Moisture Content - %	17.6	20.3	17.6	
Dry Density - pcf	107.9	106.2	107.7	
Diameter - inches	2.76	2.76	2.77	
Height - inches	5.68	5.68	5.68	
AT TEST				
Final Moisture - %	24.0	22.3	22.0	
Dry Density - pcf	108.5	107.0	109.8	
Calculated Diameter (in.)	2.76	2.75	2.75	
Height - inches	5.67	5.64	5.62	
Effect. Cell Pressure - psi	10.0	20.0	40.0	
Failure Stress - psi	19.56	19.31	36.95	
Total Pore Pressure - psi	54.4	61.2	70.5	
Strain Rate - inches/min.	0.00050	0.00050	0.00050	
Failure Strain - %	1.5	1.5	2.1	
$\sigma_1$ Failure - psi	29.56	39.31	76.95	
$\sigma_3$ Failure - psi	10.00	20.00	40.00	

### TEST DESCRIPTION

TYPE OF TEST & NO: CU with PP  
 SAMPLE TYPE: Shelby Tube Sample  
 DESCRIPTION: Redd. Brown & Tan Sandy Lean Clay w/ Gravel  
 Sampled on Site, B-3 3' to 7' deep  
 ASSUMED SPECIFIC GRAVITY: 2.7 + 40 Sieve  
 LL:            PL:            PI:            Percent -200:  
 REMARKS: Diameter and Both Ends Trimmed + # 4 Sieve

### PROJECT INFORMATION

PROJECT: Flint Creek Power Plant  
 LOCATION: Centry, AR  
 PROJECT NO: G 3243 - 09  
 CLIENT: AEP  
 December 2009

**ETTL ENGINEERS & CONSULTANTS**

**PLATE: B.3**

## Analysis of Rock Strength using RocLab

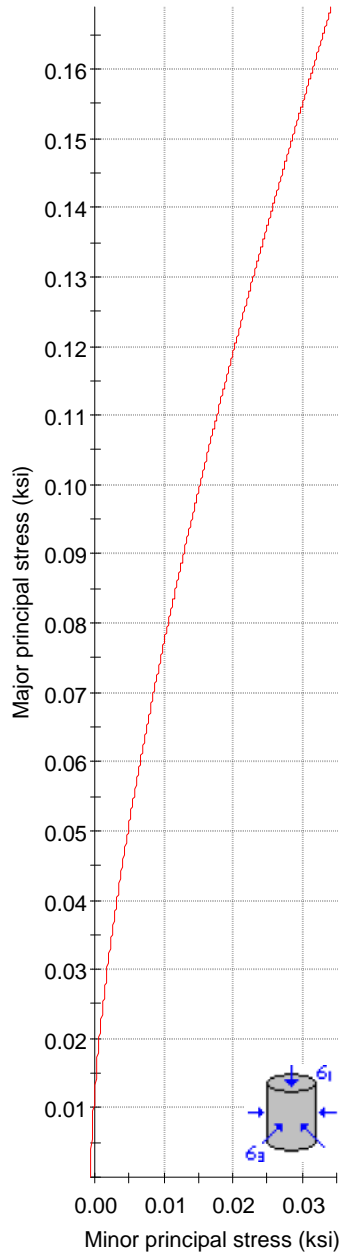

### Hoek-Brown Classification

intact uniaxial comp. strength ( $\sigma_{ci}$ ) = 4.5 ksi  
GSI = 10  $m_i$  = 8 Disturbance factor (D) = 0  
intact modulus ( $E_i$ ) = 1600 ksi

### Hoek-Brown Criterion

$m_b$  = 0.321  $s$  = 4.54e-5  $a$  = 0.585

### Mohr-Coulomb Fit

cohesion = 0.007 ksi friction angle = 38.55 deg

### Rock Mass Parameters

tensile strength = -0.001 ksi  
uniaxial compressive strength = 0.013 ksi  
global strength = 0.209 ksi  
deformation modulus = 48.81 ksi

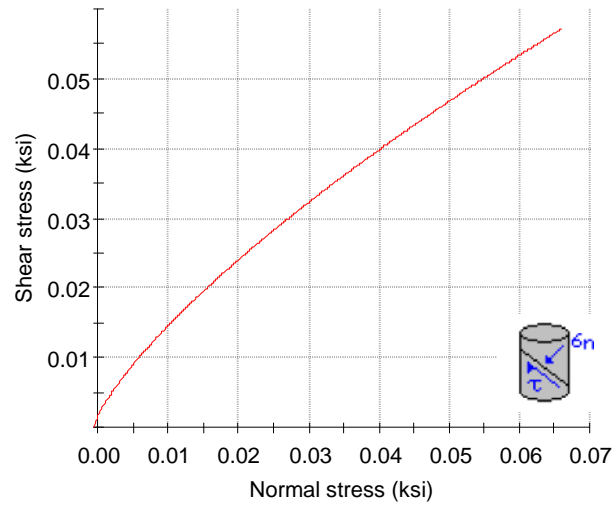





# ETTL Engineers & Consultants Inc.

GEOTECHNICAL \* MATERIALS \* ENVIRONMENTAL \* DRILLING \* LANDFILLS

## HYDRAULIC CONDUCTIVITY DETERMINATION FLEXIBLE WALL PERMEAMETER - CONSTANT VOLUME (Mercury Permometer Test)

Project :	AEP Flint Creek Power Plant Bottom Ash Ponds				
Date:	12/29/2009	Panel Number : P-3 ; ASTM D 5084			
Project No. :	G 3243-095	Permometer Data			
Boring No.:	B-1	$a_p = 0.031416 \text{ cm}^2$	Set Mercury to Pipet Rp at beginning	Equilibrium	1.7 $\text{cm}^3$
Sample:		$a_a = 0.767120 \text{ cm}^2$		Pipet Rp	6.7 $\text{cm}^3$
Depth (ft):	18'-20'	$M_1 = 0.030180$	$C = 0.000433212$	Annulus Ra	1.5 $\text{cm}^3$
Other Location:		$M_2 = 1.040953$	$T = 0.201660671$		
Material Description :	Gray, Tan & Red Clayey Gravel				

### SAMPLE DATA

Wet Wt. sample + ring or tare :	538.52 g			
Tare or ring Wt. :	0.0 g	Before Test	After Test	
Wet Wt. of Sample :	538.52 g	Tare No.:	T-5	
Diameter :	2.76 in	7.01 $\text{cm}^2$	Tare No.:	T-25
Length :	2.74 in	6.97 cm	Wet Wt.+tare:	538.52
Area:	5.97 $\text{in}^2$	38.54 $\text{cm}^2$	Dry Wt.+tare:	433.64
Volume :	16.40 $\text{in}^3$	268.68 $\text{cm}^3$	Tare Wt.:	0.00
Unit Wt. (wet):	125.07 pcf	2.00 $\text{g/cm}^3$	Dry Wt.:	433.64
Unit Wt. (dry):	100.71 pcf	1.61 $\text{g/cm}^3$	Water Wt.:	104.88
			% moist.:	24.2
			% moist.:	26.0

Assumed Specific Gravity: **2.75** Max Dry Density(pcf) = **100.7528** OMC = **24.1859607**

% of max = **100.0** +/- OMC = **0.00**

Calculated % saturation: **101.46** Void ratio (e) = **0.70** Porosity (n) = **0.41**

### TEST READINGS

$Z_1$ (Mercury Height Difference @  $t_1$ ): **5.2** cm Hydraulic Gradient = **9.33**

Date	elapsed t (seconds)	Z (pipet @ t)	$\Delta Z_p$ (cm)	temp (deg C)	$\alpha$ (temp corr)	k (cm/sec)	k (ft./day)	Reset = *
12/29/2009	3300	6	0.6588251	24.5	0.899	1.68E-08	4.77E-05	
12/29/2009	4080	5.9	0.7588251	24.5	0.899	1.59E-08	4.50E-05	
12/29/2009	4980	5.8	0.8588251	24.5	0.899	1.49E-08	4.22E-05	
12/29/2009	6120	5.7	0.9588251	24.5	0.899	1.37E-08	3.88E-05	

### SUMMARY

$k_a = 1.53\text{E-}08 \text{ cm/sec}$	Acceptance criteria =	25 %
$k_i$	$V_m$	
$k_1 = 1.68\text{E-}08 \text{ cm/sec}$	9.9 %	$V_m = \frac{ k_a - k_i }{k_a} \times 100$
$k_2 = 1.59\text{E-}08 \text{ cm/sec}$	3.6 %	
$k_3 = 1.49\text{E-}08 \text{ cm/sec}$	2.8 %	
$k_4 = 1.37\text{E-}08 \text{ cm/sec}$	10.7 %	

Hydraulic conductivity	$k = 1.53\text{E-}08 \text{ cm/sec}$	<b>4.34E-05</b> ft/day
Void Ratio	$e = 0.70$	
Porosity	$n = 0.41$	
Bulk Density	$\gamma = 2.00 \text{ g/cm}^3$	125.1 pcf
Water Content	$W = 0.39 \text{ cm}^3/\text{cm}^3$	( at 20 deg C)
Intrinsic Permeability	$k_{int} = 1.57\text{E-}13 \text{ cm}^2$	( at 20 deg C)



# ETTL Engineers & Consultants Inc.

GEOTECHNICAL \* MATERIALS \* ENVIRONMENTAL \* DRILLING \* LANDFILLS

## HYDRAULIC CONDUCTIVITY DETERMINATION FLEXIBLE WALL PERMEAMETER - CONSTANT VOLUME (Mercury Permometer Test)

Project :	AEP Flint Creek Power Plant Bottom Ash Ponds				
Date:	12/29/2009	Panel Number : P-3 ; ASTM D 5084			
Project No. :	G 3243-095	Permometer Data			
Boring No.:	B-1	$a_p = 0.031416 \text{ cm}^2$	Set Mercury to Pipet Rp at beginning	Equilibrium	1.8 $\text{cm}^3$
Sample:		$a_a = 0.767120 \text{ cm}^2$		Pipet Rp	6.7 $\text{cm}^3$
Depth (ft):	33'-35'	$M_1 = 0.030180$	$C = 0.000429887$	Annulus Ra	1.5 $\text{cm}^3$
Other Location:		$M_2 = 1.040953$	$T = 0.203783414$		
Material Description :	Red & Tan Lean Clay				

### SAMPLE DATA

Wet Wt. sample + ring or tare :	584.74 g		
Tare or ring Wt. :	0.0 g	Before Test	After Test
Wet Wt. of Sample :	584.74 g	Tare No.:	T-7 Tare No.:
Diameter :	2.79 in	7.09 $\text{cm}^2$	Wet Wt.+tare: 698.21
Length :	2.79 in	7.08 cm	Dry Wt.+tare: 599.86
Area:	6.12 $\text{in}^2$	39.47 $\text{cm}^2$	Tare Wt: 112.38
Volume :	17.06 $\text{in}^3$	279.61 $\text{cm}^3$	Dry Wt.: 487.48
Unit Wt. (wet):	130.49 pcf	2.09 $\text{g/cm}^3$	Water Wt.: 98.35
Unit Wt. (dry):	110.22 pcf	1.77 $\text{g/cm}^3$	% moist.: 20.2

Assumed Specific Gravity:	2.72	Max Dry Density(pcf) =	110.2688	OMC =	18.3917526
Calculated % saturation:	101.51	% of max =	100.0	+/- OMC =	0.00
		Void ratio (e) =	0.54	Porosity (n)=	0.35

### TEST READINGS

$Z_1$ (Mercury Height Difference @ $t_1$ ):	5.1 cm	Hydraulic Gradient =	9.09					
Date	elapsed t (seconds)	Z (pipet @ t)	$\Delta Z_p$ (cm)	temp (deg C)	$\alpha$ (temp corr)	k (cm/sec)	k (ft./day)	Reset = *
12/29/2009	3480	6	0.657171	24.5	0.899	1.60E-08	4.53E-05	
12/29/2009	4260	5.9	0.757171	24.5	0.899	1.52E-08	4.31E-05	
12/29/2009	4920	5.8	0.857171	24.5	0.899	1.51E-08	4.28E-05	
12/29/2009	6420	5.6	1.057171	24.5	0.899	1.46E-08	4.14E-05	

### SUMMARY

$k_a = 1.52E-08 \text{ cm/sec}$	Acceptance criteria =	25 %
$k_i$	$V_m$	
$k_1 = 1.60E-08 \text{ cm/sec}$	4.9 %	$V_m = \frac{ k_a - k_i }{k_a} \times 100$
$k_2 = 1.52E-08 \text{ cm/sec}$	0.1 %	
$k_3 = 1.51E-08 \text{ cm/sec}$	0.9 %	
$k_4 = 1.46E-08 \text{ cm/sec}$	4.0 %	

Hydraulic conductivity	$k = 1.52E-08 \text{ cm/sec}$	$4.31E-05 \text{ ft/day}$
Void Ratio	$e = 0.54$	
Porosity	$n = 0.35$	
Bulk Density	$\gamma = 2.09 \text{ g/cm}^3$	130.5 pcf
Water Content	$W = 0.33 \text{ cm}^3/\text{cm}^3$	( at 20 deg C)
Intrinsic Permeability	$k_{int} = 1.56E-13 \text{ cm}^2$	( at 20 deg C)



# ETTL Engineers & Consultants Inc.

GEOTECHNICAL \* MATERIALS \* ENVIRONMENTAL \* DRILLING \* LANDFILLS

## HYDRAULIC CONDUCTIVITY DETERMINATION FLEXIBLE WALL PERMEAMETER - CONSTANT VOLUME (Mercury Permometer Test)

Project :	AEP Flint Creek Power Plant Bottom Ash Ponds				
Date:	12/29/2009	Panel Number : P-3 ; ASTM D 5084			
Project No. :	G 3243-095	Permometer Data			
Boring No.:	B-2	$a_p = 0.031416 \text{ cm}^2$	Set Mercury to Pipet Rp at beginning	Equilibrium	1.7 $\text{cm}^3$
Sample:		$a_a = 0.767120 \text{ cm}^2$		Pipet Rp	6.7 $\text{cm}^3$
Depth (ft):	8'-10'	$M_1 = 0.030180$	$C = 0.000430497$	Annulus Ra	1.5 $\text{cm}^3$
Other Location:		$M_2 = 1.040953$	$T = 0.201660671$		
Material Description :	Red & Tan Clayey Gravel				

### SAMPLE DATA

Wet Wt. sample + ring or tare :	570.81 g		
Tare or ring Wt. :	0.0 g	Before Test	After Test
Wet Wt. of Sample :	570.81 g	Tare No.:	T-2 Tare No.:
Diameter :	2.78 in	7.06 $\text{cm}^2$	Wet Wt.+tare: 299.84
Length :	2.77 in	7.03 cm	Wet Wt.+tare: 715.92
Area:	6.06 $\text{in}^2$	39.10 $\text{cm}^2$	Dry Wt.+tare: 287.43
Volume :	16.77 $\text{in}^3$	274.83 $\text{cm}^3$	Dry Wt.+tare: 608.75
Unit Wt. (wet):	129.60 pcf	2.08 $\text{g/cm}^3$	Tare Wt: 216.62
Unit Wt. (dry):	110.28 pcf	1.77 $\text{g/cm}^3$	Tare Wt: 140.31
			Dry Wt.: 70.81
			Dry Wt.: 468.44
			Water Wt.: 12.41
			Water Wt.: 107.17
			% moist.: 17.5
			% moist.: 22.9

Assumed Specific Gravity: **2.95** Max Dry Density(pcf) = **110.3225** OMC = **17.5257732**

% of max = **100.0** +/- OMC = **0.00**

Calculated % saturation: **100.72** Void ratio (e) = **0.67** Porosity (n) = **0.40**

### TEST READINGS

$Z_1$ (Mercury Height Difference @  $t_1$ ): **5.2** cm Hydraulic Gradient = **9.25**

Date	elapsed t (seconds)	Z (pipet @ t)	$\Delta Z_p$ (cm)	temp (deg C)	$\alpha$ (temp corr)	k (cm/sec)	k (ft./day)	Reset = *
12/29/2009	2460	6.3	0.3588251	24.5	0.899	1.18E-08	3.35E-05	
12/29/2009	3900	6.2	0.4588251	24.5	0.899	9.64E-09	2.73E-05	
12/29/2009	5520	6.1	0.5588251	24.5	0.899	8.39E-09	2.38E-05	
12/29/2009	7200	6	0.6588251	24.5	0.899	7.67E-09	2.17E-05	

### SUMMARY

$k_a = 9.38E-09 \text{ cm/sec}$	Acceptance criteria =	50 %
$k_i$	$V_m$	
$k_1 = 1.18E-08 \text{ cm/sec}$	26.1 %	$V_m = \frac{ k_a - k_i }{k_a} \times 100$
$k_2 = 9.64E-09 \text{ cm/sec}$	2.8 %	
$k_3 = 8.39E-09 \text{ cm/sec}$	10.6 %	
$k_4 = 7.67E-09 \text{ cm/sec}$	18.3 %	

Hydraulic conductivity	$k = 9.38E-09 \text{ cm/sec}$	<b>2.66E-05</b> ft/day
Void Ratio	$e = 0.67$	
Porosity	$n = 0.40$	
Bulk Density	$\gamma = 2.08 \text{ g/cm}^3$	<b>129.6</b> pcf
Water Content	$W = 0.31 \text{ cm}^3/\text{cm}^3$	( at 20 deg C)
Intrinsic Permeability	$k_{int} = 9.61E-14 \text{ cm}^2$	( at 20 deg C)

210 Beech Street  
Texarkana, AR 71854  
870-772-0013 Phone  
870-216-2413 Fax

1717 East Erwin  
Tyler, Texas 75702  
903-595-4421 Phone  
903-595-6113 Fax  
www.ettlinc.com

707 West Cotton Street  
Longview, Texas 75604-5505  
903-758-0915 Phone  
903-758-8245 Fax



# ETTL Engineers & Consultants Inc.

GEOTECHNICAL \* MATERIALS \* ENVIRONMENTAL \* DRILLING \* LANDFILLS

## HYDRAULIC CONDUCTIVITY DETERMINATION FLEXIBLE WALL PERMEAMETER - CONSTANT VOLUME (Mercury Permometer Test)

Project :	AEP Flint Creek Power Plant Bottom Ash Ponds				
Date:	12/29/2009	Panel Number : P-3 ; ASTM D 5084			
Project No. :	G 3243-095	Permometer Data			
Boring No.:	B-2	$a_p = 0.031416 \text{ cm}^2$	Set Mercury to Pipet Rp at beginning	Equilibrium	1.7 $\text{cm}^3$
Sample:		$a_a = 0.767120 \text{ cm}^2$		Pipet Rp	6.7 $\text{cm}^3$
Depth (ft):	23'-25'	$M_1 = 0.030180$	$C = 0.000430195$	Annulus Ra	1.5 $\text{cm}^3$
Other Location:		$M_2 = 1.040953$	$T = 0.201660671$		
Material Description :	Red & Tan Sandy Lean Clay				

### SAMPLE DATA

Wet Wt. sample + ring or tare :	586.16 g		
Tare or ring Wt. :	0.0 g	Before Test	After Test
Wet Wt. of Sample :	586.16 g	Tare No.:	T-8 Tare No.:
Diameter :	2.79 in	7.08 $\text{cm}^2$	Wet Wt.+tare: 586.16
Length :	2.79 in	7.07 cm	Wet Wt.+tare: 730.20
Area:	6.10 $\text{in}^2$	39.39 $\text{cm}^2$	Dry Wt.+tare: 505.60
Volume :	17.00 $\text{in}^3$	278.61 $\text{cm}^3$	Dry Wt.: 140.46
Unit Wt. (wet):	131.28 pcf	2.10 $\text{g/cm}^3$	Dry Wt.: 505.6
Unit Wt. (dry):	113.24 pcf	1.81 $\text{g/cm}^3$	Water Wt.: 80.56
			% moist.: 15.9
			% moist.: 16.6

Assumed Specific Gravity:	2.60	Max Dry Density(pcf) =	113.2859	OMC =	15.9335443
Calculated % saturation:	99.83	% of max =	100.0	+/- OMC =	0.00
		Void ratio (e) =	0.43	Porosity (n)=	0.30

### TEST READINGS

$Z_1$ (Mercury Height Difference @ $t_1$ ):	5.2 cm	Hydraulic Gradient =	9.19
---	--------	----------------------	------

Date	elapsed t (seconds)	Z (pipet @ t)	$\Delta Z_p$ (cm)	temp (deg C)	$\alpha$ (temp corr)	k (cm/sec)	k (ft./day)	Reset = *
12/29/2009	2400	6	0.6588251	24	0.910	2.32E-08	6.59E-05	
12/29/2009	3540	5.7	0.9588251	24	0.910	2.38E-08	6.73E-05	
12/29/2009	3960	5.6	1.0588251	24	0.910	2.37E-08	6.73E-05	
12/29/2009	4380	5.5	1.1588251	24	0.910	2.38E-08	6.74E-05	

### SUMMARY

$k_a =$	2.36E-08 cm/sec	Acceptance criteria =	25 %
$k_i$		$V_m$	
$k_1 =$	2.32E-08 cm/sec	1.6 %	$V_m = \frac{ k_a - k_i }{k_a} \times 100$
$k_2 =$	2.38E-08 cm/sec	0.5 %	
$k_3 =$	2.37E-08 cm/sec	0.5 %	
$k_4 =$	2.38E-08 cm/sec	0.6 %	

Hydraulic conductivity	$k =$	2.36E-08 cm/sec	6.70E-05 ft/day
Void Ratio	$e =$	0.43	
Porosity	$n =$	0.30	
Bulk Density	$\gamma =$	2.10 $\text{g/cm}^3$	131.3 pcf
Water Content	$W =$	0.29 $\text{cm}^3/\text{cm}^3$	( at 20 deg C)
Intrinsic Permeability	$k_{int} =$	2.42E-13 $\text{cm}^2$	( at 20 deg C)



# ETTL Engineers & Consultants Inc.

GEOTECHNICAL \* MATERIALS \* ENVIRONMENTAL \* DRILLING \* LANDFILLS

## HYDRAULIC CONDUCTIVITY DETERMINATION FLEXIBLE WALL PERMEAMETER - CONSTANT VOLUME (Mercury Permometer Test)

Project :	AEP Flint Creek Power Plant Bottom Ash Ponds				
Date:	12/29/2009	Panel Number : P-3 ; ASTM D 5084			
Project No. :	G 3243-095	Permometer Data			
Boring No.:	B-7	$a_p = 0.031416 \text{ cm}^2$	Set Mercury to Pipet Rp at beginning	Equilibrium	1.7 $\text{cm}^3$
Sample:		$a_a = 0.767120 \text{ cm}^2$		Pipet Rp	6.7 $\text{cm}^3$
Depth (ft):	5'-7'	$M_1 = 0.030180$	$C = 0.000434383$	Annulus Ra	1.5 $\text{cm}^3$
Other Location:		$M_2 = 1.040953$	$T = 0.201660671$		
Material Description :	Red & Tan Sandy Lean Clay with gravel				

### SAMPLE DATA

Wet Wt. sample + ring or tare :	540.64 g		
Tare or ring Wt. :	0.0 g	Before Test	After Test
Wet Wt. of Sample :	540.64 g	Tare No.:	T-4 Tare No.:
Diameter :	2.75 in	6.98 $\text{cm}^2$	Wet Wt.+tare: 439.69
Length :	2.73 in	6.94 cm	Wet Wt.+tare: 707.29
Area:	5.93 $\text{in}^2$	38.26 $\text{cm}^2$	Dry Wt.+tare: 400.57
Volume :	16.20 $\text{in}^3$	265.52 $\text{cm}^3$	Dry Wt.+tare: 600.06
Unit Wt. (wet):	127.05 pcf	2.04 $\text{g/cm}^3$	Tare Wt: 219.47
Unit Wt. (dry):	104.48 pcf	1.67 $\text{g/cm}^3$	Tare Wt: 160.23
			Dry Wt.: 181.1
			Dry Wt.: 439.83
			Water Wt.: 39.12
			Water Wt.: 107.23
			% moist.: 21.6
			% moist.: 24.4

Assumed Specific Gravity: **2.80** Max Dry Density(pcf) =  $\frac{104.5286}{1.67} = 62.59$  OMC =  $\frac{21.6013252}{1.67} = 12.93$

% of max =  $\frac{100.0}{62.59} = 1.60$  +/- OMC =  $\frac{0.00}{1.67} = 0.00$

Calculated % saturation: **101.43** Void ratio (e) = **0.67** Porosity (n) = **0.40**

### TEST READINGS

$Z_1$ (Mercury Height Difference @ $t_1$ ):	5.2 cm	Hydraulic Gradient =	9.37
---	--------	----------------------	------

Date	elapsed t (seconds)	Z (pipet @ t)	$\Delta Z_p$ (cm)	temp (deg C)	$\alpha$ (temp corr)	k (cm/sec)	k (ft./day)	Reset = *
12/29/2009	3120	5.9	0.7588251	24.5	0.899	2.08E-08	5.90E-05	
12/29/2009	3720	5.8	0.8588251	24.5	0.899	2.00E-08	5.66E-05	
12/29/2009	4380	5.7	0.9588251	24.5	0.899	1.92E-08	5.43E-05	
12/29/2009	5040	5.6	1.0588251	24.5	0.899	1.86E-08	5.28E-05	

### SUMMARY

$k_a = 1.96E-08 \text{ cm/sec}$	Acceptance criteria =	25 %
$k_i$	$V_m$	
$k_1 = 2.08E-08 \text{ cm/sec}$	5.9 %	$V_m = \frac{ k_a - k_i }{k_a} \times 100$
$k_2 = 2.00E-08 \text{ cm/sec}$	1.7 %	
$k_3 = 1.92E-08 \text{ cm/sec}$	2.4 %	
$k_4 = 1.86E-08 \text{ cm/sec}$	5.2 %	

Hydraulic conductivity	$k = 1.96E-08 \text{ cm/sec}$	$5.57E-05 \text{ ft/day}$
Void Ratio	$e = 0.67$	
Porosity	$n = 0.40$	
Bulk Density	$\gamma = 2.04 \text{ g/cm}^3$	127.1 pcf
Water Content	$W = 0.36 \text{ cm}^3/\text{cm}^3$	( at 20 deg C)
Intrinsic Permeability	$k_{int} = 2.01E-13 \text{ cm}^2$	( at 20 deg C)

210 Beech Street  
Texarkana, AR 71854  
870-772-0013 Phone  
870-216-2413 Fax

1717 East Erwin  
Tyler, Texas 75702  
903-595-4421 Phone  
903-595-6113 Fax  
www.ettlinc.com

707 West Cotton Street  
Longview, Texas 75604-5505  
903-758-0915 Phone  
903-758-8245 Fax

**ENVIRONMENTAL LOG**

**Client:** Flint Creek Power Plant

**Project No:** G3243-09

**Phase**

**Task**

**Well No.** B-1

**Location** Gentry, Arkansas

**Surface Elev.**

**Page 1 of 2**

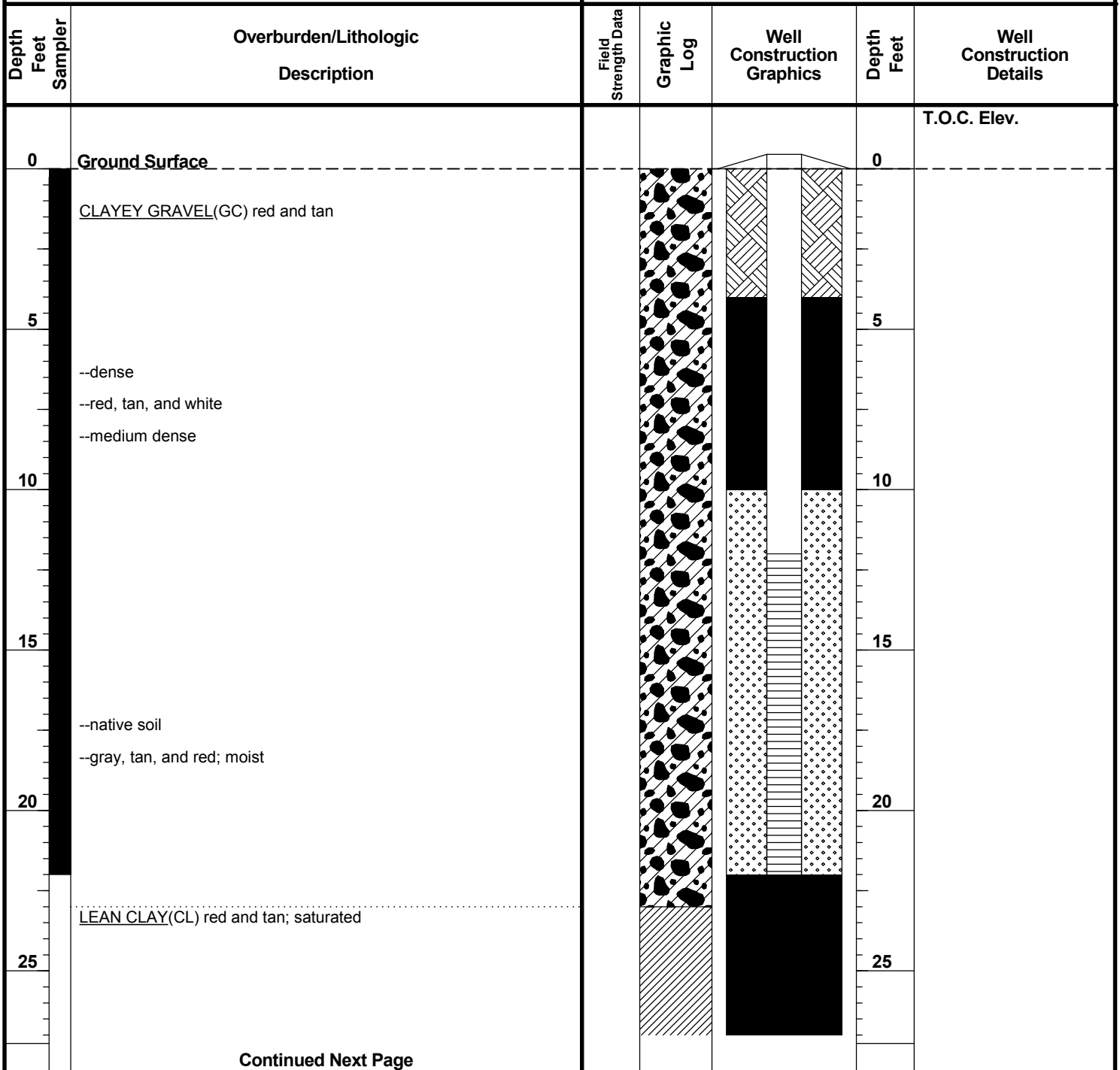

Continued Next Page

**Driller** Tommy Cook  
**Logged By** James Griffith  
**Drilling Started** 11/3/09  
**Drilling Completed** 11/3/09  
**Construction Completed** \_\_\_\_\_  
**Development Completed** \_\_\_\_\_  
**Type of Well** \_\_\_\_\_

**Drilling Method** Rotary Wash  
**Borehole Diameter** 6.5"  
**Well Casing** 2.0" Dia. 0.0' to 12.0'  
**Casing Type** PVC  
**Well Screen** 2.0" Dia. 12.0' to 22.0'  
**Screen Type** Slotted  
**Slot Size** 0.010"  
**Grout Type** Bentonite

**Bentonite Seal** 0-4' & 22-48'  
**Filter Pack Qty.** 10-22'  
**Filter Pack Type** 20/40 Sand  
**Static Water Level** \_\_\_\_\_  
**Notes:** Seepage @ 25' while drilling.



**ENVIRONMENTAL LOG**

**Client:** Flint Creek Power Plant

**Project No:** G3243-09

**Phase**







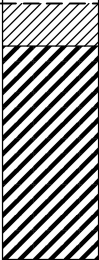

**Task**

**Well No.** B-1

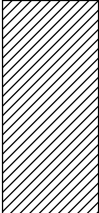
**Location** Gentry, Arkansas

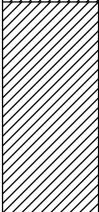
**Surface Elev.**

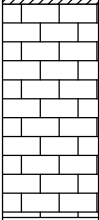
**Page 2 of 2**

Depth Feet Sampler	Overburden/Lithologic Description	Field Strength Data	Graphic Log	Well Construction Graphics	Depth Feet	Well Construction Details
Continued from previous page						
30	<u>SANDY FAT CLAY(CH)</u> hard; red and tan; with gravel				30	
35	<u>LEAN CLAY(CL)</u> very stiff; red and tan				35	
40	<u>LEAN CLAY WITH SAND(CL)</u> very stiff; red and gray				40	
45	<u>LIMESTONE</u> moderately strong; limestone seams ~16"; gray; crystalline clay; thick bedded; fresh; unfeathered --RQD<0.25				45	
50	Bottom of Boring @ 48'					
55						
60						



**ENVIRONMENTAL LOG**

**Client:** Flint Creek Power Plant

**Project No:** G3243-09

**Phase**

**Task**

**Well No.** B-2

**Location** Gentry, Arkansas

**Surface Elev.**

**Page 1 of 2**

Depth Feet Sampler	Overburden/Lithologic Description	Field Strength Data	Graphic Log	Well Construction Graphics	Depth Feet	Well Construction Details
0	<b>Ground Surface</b>				0	T.O.C. Elev.
	CLAYEY GRAVEL(GC) medium dense; red and tan; with gravel					
	FAT CLAY WITH SAND(CH) stiff; red and tan					
5					5	
	CLAYEY GRAVEL(GC) medium dense; red and tan; with sand and gravel					
10					10	
	SANDY LEAN CLAY(CL) red and tan; with gravel					
15					15	
	CLAYEY GRAVEL(GC) medium dense; red and tan; moist --native soil					
20					20	
	SANDY LEAN CLAY(CL) very stiff; red and tan; with gravel					
25					25	

Continued Next Page

**Driller** Tommy Cook  
**Logged By** James Griffith  
**Drilling Started** 11/3/09  
**Drilling Completed** 11/3/09  
**Construction Completed**  
**Development Completed**  
**Type of Well**

**Drilling Method** Rotary Wash  
**Borehole Diameter** 6.5"  
**Well Casing** 2.0" Dia. 0.0' to 15.0'  
**Casing Type** PVC  
**Well Screen** 2.0" Dia. 15.0' to 25.0'  
**Screen Type** Slotted  
**Slot Size** 0.010"  
**Grout Type** Bentonite

**Bentonite Seal** 0-3' & 25-50'  
**Filter Pack Qty.** 13-25'  
**Filter Pack Type** 20/40 Sand  
**Static Water Level**  
**Notes:** Seepage @ 20' while drilling.





**ENVIRONMENTAL LOG**

**Client:** Flint Creek Power Plant

**Project No:** G3243-09

**Phase**







**Task**

**Well No.** B-2

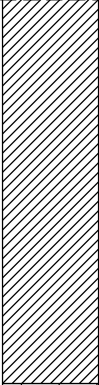
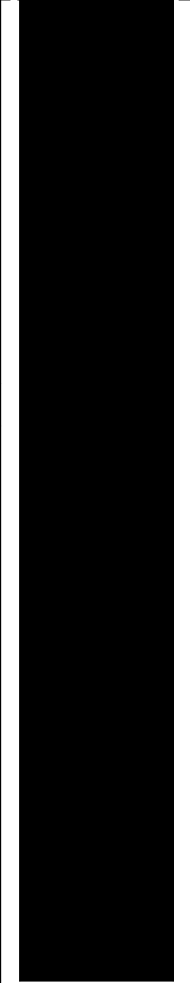
**Location** Gentry, Arkansas

**Surface Elev.**

**Page 2 of 2**

Depth Feet Sampler	Overburden/Lithologic Description	Field Strength Data	Graphic Log	Well Construction Graphics	Depth Feet	Well Construction Details
Continued from previous page						
30					30	
35	<p>LIMESTONE ~ 14" thick layer</p> <p>LIMESTONE ~ 8" thick limestone ledge</p>					
40					40	
45	<p>--rock cuttings; RQD&lt;0.25</p> <p>--solid rock seam @ 48'</p>				45	
50	<p align="center">Bottom of Boring @ 50'</p>				50	
55						
60						



**ENVIRONMENTAL LOG**

**Client:** Flint Creek Power Plant

**Project No:** G3243-09

**Phase**



**Task**

**Well No.** B-3

**Location** Gentry, Arkansas

**Surface Elev.**

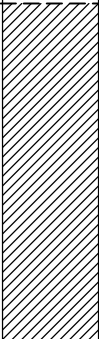
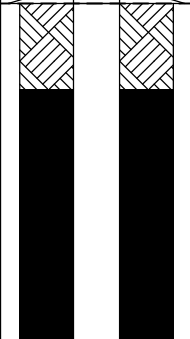
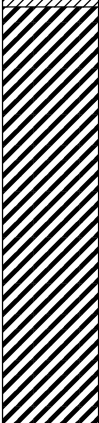
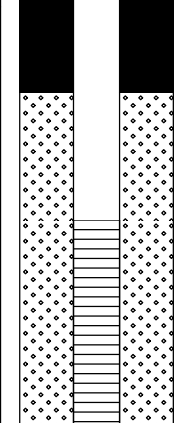
**Page 1 of 2**

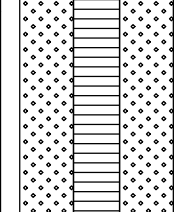
Depth Feet Sampler	Overburden/Lithologic Description	Field Strength Data	Graphic Log	Well Construction Graphics	Depth Feet	Well Construction Details
0	<b>Ground Surface</b>				0	T.O.C. Elev.
	SANDY LEAN CLAY(CL) very stiff; gray and tan; with gravel					
	--brown and red; with gravel					
5					5	
	--gray and tan; with gravel					
	SANDY FAT CLAY(CH) stiff; tan and red; with gravel					
10					10	
	--very stiff					
15					15	
	CLAYEY GRAVEL(GC) medium dense; gray and tan; with gravel					
20					20	
	--native soil					
	--brown					
25					25	

Continued Next Page

**Driller** Tommy Cook

**Logged By** James Griffith

**Drilling Started** 11/4/09

**Drilling Completed** 11/4/09

**Construction Completed** \_\_\_\_\_

**Development Completed** \_\_\_\_\_

**Type of Well** \_\_\_\_\_

**Drilling Method** Rotary Wash

**Borehole Diameter** 6.5"

**Well Casing** 2.0" Dia. 0.0' to 13.0'

**Casing Type** PVC

**Well Screen** 2.0" Dia. 13.0' to 23.0'

**Screen Type** Slotted

**Slot Size** 0.010"

**Grout Type** Bentonite

**Bentonite Seal** 0-2' & 23-37'

**Filter Pack Qty.** 13-23'

**Filter Pack Type** 20/40 Sand

**Static Water Level** \_\_\_\_\_

**Notes:** \_\_\_\_\_



**ENVIRONMENTAL LOG**

**Client:** Flint Creek Power Plant

**Well No.** B-3

**Location** Gentry, Arkansas



**Project No:** G3243-09

**Phase**

**Task**

**Surface Elev.**

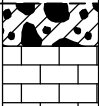
**Page 2 of 2**

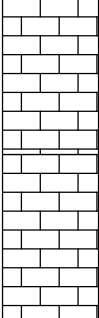
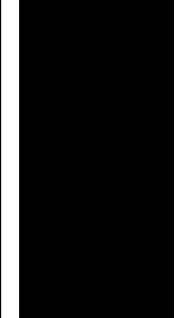
Depth Feet Sampler	Overburden/Lithologic Description	Field Strength Data	Graphic Log	Well Construction Graphics	Depth Feet	Well Construction Details
Continued from previous page						
30	<p>LIMESTONE rock cuttings</p> <p>--RQD&lt;0.25</p>				30	
35	<p>LIMESTONE</p> <p>--RQD&lt;0.25</p> <p>Bottom of Boring @ 37'</p>				35	
40						
45						
50						
55						
60						



**ENVIRONMENTAL LOG**

**Client:** Flint Creek Power Plant

**Project No:** G3243-09

**Phase**







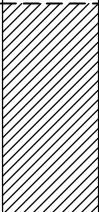
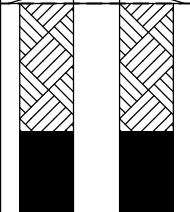

**Task**

**Well No.** B-4

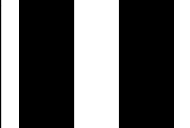
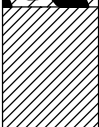
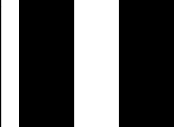
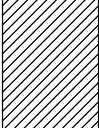
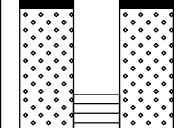
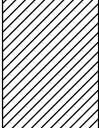
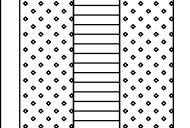
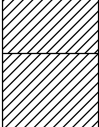
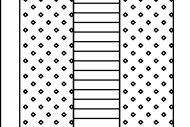
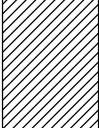
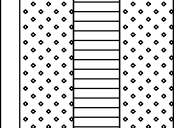
**Location** Gentry, Arkansas

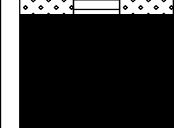
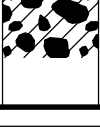
**Surface Elev.**

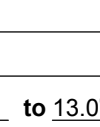
**Page 1 of 2**

Depth Feet Sampler	Overburden/Lithologic Description	Field Strength Data	Graphic Log	Well Construction Graphics	Depth Feet	Well Construction Details
0	<b>Ground Surface</b>				0	T.O.C. Elev.
	SANDY LEAN CLAY(CL) stiff; tan and gray; with gravel					
5	CLAYEY GRAVEL(GC) medium dense; tan and red				5	
	LEAN CLAY WITH GRAVEL(CL) stiff; red and tan					
10	--reddish brown and tan				10	
	SANDY LEAN CLAY(CL) very stiff; tan and gray; with gravel					
15	--native soil				15	
	SANDY LEAN CLAY(CL) very stiff; tan and gray; with gravel					
20	--native soil				20	
	CLAYEY GRAVEL(GC) medium dense; tan and red; with gravel					
25					25	

Continued Next Page

<b>Driller</b> Tommy Cook	<b>Drilling Method</b> Rotary Wash	<b>Bentonite Seal</b> 0-3' & 23-50'
<b>Logged By</b> James Griffith	<b>Borehole Diameter</b> 6.5"	<b>Filter Pack Qty.</b> 13-23'
<b>Drilling Started</b> 11/4/09	<b>Well Casing</b> 2.0" Dia. 0.0' to 13.0'	<b>Filter Pack Type</b> 20/40 Sand
<b>Drilling Completed</b> 11/4/09	<b>Casing Type</b> PVC	<b>Static Water Level</b> _____
<b>Construction Completed</b> _____	<b>Well Screen</b> 2.0" Dia. 13.0' to 23.0'	<b>Notes:</b> _____ _____ _____
<b>Development Completed</b> _____	<b>Screen Type</b> Slotted	
<b>Type of Well</b> _____	<b>Slot Size</b> 0.010"	
	<b>Grout Type</b> Bentonite	



**ENVIRONMENTAL LOG**

**Client:** Flint Creek Power Plant

**Project No:** G3243-09

**Phase**





**Task**

**Well No.** B-4

**Location** Gentry, Arkansas

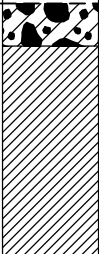
**Surface Elev.**

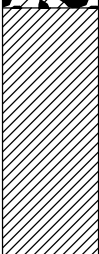
**Page 2 of 2**

Depth Feet Sampler	Overburden/Lithologic Description	Field Strength Data	Graphic Log	Well Construction Graphics	Depth Feet	Well Construction Details
Continued from previous page						
30	SANDY LEAN CLAY(CL) very stiff; tan, red, and gray; with gravel				30	
35	CLAYEY GRAVEL(GC) loose; tan, gray, and red; saturated				35	
40	SANDY LEAN CLAY(CL) very stiff; tan, gray, and red; with gravel				40	
45	--soft GRAVEL(GP) white				45	
50	SANDY LEAN CLAY(CL) stiff; red; with gravel				50	
	Bottom of Boring @ 50'					
55						
60						

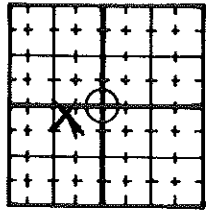

**STATE OF ARKANSAS  
REPORT ON WATER WELL CONSTRUCTION & PUMP INSTALLATION**

<b>A</b> 1 Contractor Name & Number: <u>ETTL Engineers &amp; Consultants Inc</u> c# <u>1401</u>					10 LOCATE WITH 'X' IN SECTION BELOW 
2 Driller Name & Number: <u>Thomas Cook</u> d# <u>2418</u>					
3 Pump Installer Name & Number: _____ p# _____					
4 Date Well Completed: <u>Nov. 3, 2009</u> New Well <input checked="" type="checkbox"/> Replace or Work-over <input type="checkbox"/>					
5 COUNTY <u>Benton</u>	6 FRACTION <u>NE 1/4 of SW 1/4 of 8</u>	7 SECTION <u>8</u>	8 TOWNSHIP <u>T18N</u>	9 RANGE <u>R33W</u>	
LONGITUDE 11 <u>94</u> ° <u>31</u> ' <u>29.8</u> "			LATITUDE 11 <u>36</u> ° <u>15</u> ' <u>0.3</u> "		

<b>B</b> 1 DESCRIPTION OF FORMATION: DEPTHS IN FEET		
B-1	FROM	TO
clayey sand-Red, Tan & Gray	0	22
<i>ATTACH ADDITIONAL SHEETS IF NECESSARY</i>		
2 TOTAL DEPTH OF WELL	22	ft
3 DEPTHS TO WATER PRODUCING FORMATIONS.	23	
4 STATIC WATER LEVEL		Ft below land surface
5 YIELD _____		gallons per <input type="checkbox"/> min <input type="checkbox"/> hr
6 DIAMETER OF BORE HOLE	6.5	IN

<b>C</b> PUMP REPORT <u>NA</u>	
1 TYPE PUMP: SUBMERSIBLE <input type="checkbox"/> TURBINE <input type="checkbox"/> JET <input type="checkbox"/>	
2 SETTING DEPTH: FEET	
3 BRAND NAME AND SERIAL NUMBERS:	
4 RATED CAPACITY	gallons per minute
5 TYPE LUBRICATION	
6 DROP PIPE OR COLUMN PIPE SIZE	
7 WIRE SIZE	
8 PRESSURE TANK . . . SIZE, MAKE, MODEL	
9 DATE OF INSTALLATION OR REPAIR	
10 Is there an abandoned water well on the property?	

<b>D</b> 1 LAND OWNER OR OTHER CONTACT PERSON:			
NAME <u>AEP</u>			
STREET ADDRESS <u>21797 SWEPCO Plant Rd.</u>			
CITY <u>Gentry, AR 72734</u>			
2 CASING	FROM 0'	TO 12'	W/ 2" ID
	FROM	TO	W/ "ID
TYPE CASING: <u>PVC</u>			
3 SCREEN			
TYPE: <u>PVC</u>	DIA <u>2"</u>	SLOT/GA <u>0.010</u>	
SET FROM <u>12</u>	FT TO <u>22</u>	FT	
TYPE:	DIA	SLOT/GA	
SET FROM	FT TO	FT	
4 GRAVEL PACK	FROM 10	FT TO 22	FT
5 BACK FILLED WITH: <u>Bentonite</u>			
	FROM 4	FT TO 10	FT
6 SEALED WITH: <u>Cement</u>			
	FROM 0	FT TO 4	FT
	FROM	FT TO	FT
7 DISINFECTED WITH: <u>NA</u>			
8 USE OF WELL:			
DOMESTIC	<input type="checkbox"/>	COMMERCIAL	<input type="checkbox"/>
IRRIGATION	<input type="checkbox"/>	MONITOR	<input checked="" type="checkbox"/>
LIVESTOCK/POULTRY	<input type="checkbox"/>	TEST WELL	<input type="checkbox"/>
OIL/GAS SUPPLY	<input type="checkbox"/>	SEMI-PUBLIC	<input type="checkbox"/>
PUBLIC SUPPLY	<input type="checkbox"/>	OTHER	<input type="checkbox"/>
(A/C HEATPUMP TYPE WELLS)			
SOURCE	<input type="checkbox"/>	RETURN	<input type="checkbox"/>
CLOSED LOOP	<input type="checkbox"/>		
9 (For A/C only) Will system also be used for purposes other than Heating or Air Conditioning? If yes, name use: _____ yes <input type="checkbox"/> no <input type="checkbox"/>			
10 (For A/C open-loop only) Into what medium is water returned?			
11 REMARKS			
<u>Flush mount surface completion</u>			
12 SIGNED: <u>Thomas Cook</u>			DATE: <u>12-9-09</u>

**STATE OF ARKANSAS  
REPORT ON WATER WELL CONSTRUCTION & PUMP INSTALLATION**

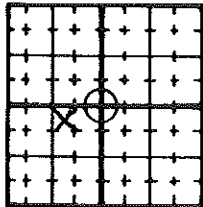
<b>A</b> 1 Contractor Name & Number: <u>ETTL Engineers &amp; Consultants Inc c# 1401</u>					10 LOCATE WITH 'X' IN SECTION BELOW 
2 Driller Name & Number: <u>Thomas Cook</u>		D# <u>2418</u>			
3 Pump Installer Name & Number: _____		P# _____			
4 Date Well Completed: <u>Nov. 3, 2009</u>		New Well <input checked="" type="checkbox"/> Replace or Work-over <input type="checkbox"/>			
5 COUNTY <u>Benton</u>	6 FRACTION <u>NE 1/4 of SW 1/4 of 8</u>	7 SECTION <u>8</u>	8 TOWNSHIP <u>T18N</u>	9 RANGE <u>R33W</u>	
LONGITUDE 11 <u>94</u> ° <u>31</u> ' <u>28.0</u> "		LATITUDE 11 <u>36</u> ° <u>15</u> ' <u>1.5</u> "			
<b>B</b> 1 DESCRIPTION OF FORMATION: DEPTHS IN FEET					
B-2		FROM	TO		
Clayey Sand- Red & Tan		0	25		
ATTACH ADDITIONAL SHEETS IF NECESSARY					
2 TOTAL DEPTH OF WELL		25 ft			
3 DEPTHS TO WATER PRODUCING FORMATIONS.		dry			
4 STATIC WATER LEVEL		Ft below land surface			
5 YIELD _____		gallons per <input type="checkbox"/> min <input type="checkbox"/> hr			
6 DIAMETER OF BORE HOLE		6.5 IN			
<b>C</b> PUMP REPORT <u>NA</u>					
1 TYPE PUMP: SUBMERSIBLE <input type="checkbox"/> TURBINE <input type="checkbox"/> JET <input type="checkbox"/>					
2 SETTING DEPTH: FEET					
3 BRAND NAME AND SERIAL NUMBERS:					
4 RATED CAPACITY _____ gallons per minute					
5 TYPE LUBRICATION					
6 DROP PIPE OR COLUMN PIPE SIZE					
7 WIRE SIZE					
8 PRESSURE TANK . . . SIZE, MAKE, MODEL					
9 DATE OF INSTALLATION OR REPAIR					
10 Is there an abandoned water well on the property?					
<b>D</b> 1 LAND OWNER OR OTHER CONTACT PERSON: NAME <u>AEP</u> STREET ADDRESS <u>21797 SWEPC Plant Rd.</u> CITY <u>Gentry, AR 72734</u>					
2 CASING		FROM 0	TO 15	W/ 2 "ID	
		FROM	TO	W/ "ID	
TYPE CASING: <u>PVC</u>					
3 SCREEN					
TYPE: <u>PVC</u>		DIA <u>2"</u>	SLOT/GA <u>0.010</u>		
SET FROM <u>1 1/2</u>		FT TO <u>2 5</u>	FT		
TYPE:		DIA	SLOT/GA		
SET FROM		FT TO	FT		
4 GRAVEL PACK		FROM 13	FT TO 25 FT		
5 BACK FILLED WITH: <u>Bentonite</u>					
FROM 3		FT TO 13 FT			
6 SEALED WITH: <u>Cement</u>					
FROM 0		FT TO 3 FT			
FROM		FT TO FT			
7 DISINFECTED WITH: <u>NA</u>					
8 USE OF WELL:					
DOMESTIC		<input type="checkbox"/>	COMMERCIAL <input type="checkbox"/>		
IRRIGATION		<input type="checkbox"/>	MONITOR <input checked="" type="checkbox"/>		
LIVESTOCK/POULTRY		<input type="checkbox"/>	TEST WELL <input type="checkbox"/>		
OIL/GAS SUPPLY		<input type="checkbox"/>	SEMI-PUBLIC <input type="checkbox"/>		
PUBLIC SUPPLY		<input type="checkbox"/>	OTHER <input type="checkbox"/>		
(A/C HEATPUMP TYPE WELLS)					
SOURCE		<input type="checkbox"/>	RETURN <input type="checkbox"/>		
CLOSED LOOP		<input type="checkbox"/>			
9 (For A/C only) Will system also be used for purposes other than Heating or Air Conditioning? If yes, name use: _____ yes <input type="checkbox"/> no <input type="checkbox"/>					
10 (For A/C open-loop only) Into what medium is water returned?					
11 REMARKS <u>Flush mount surface completion</u>					
12 SIGNED <u>Thomas Cook</u>				DATE <u>12-9-09</u>	

**STATE OF ARKANSAS  
REPORT ON WATER WELL CONSTRUCTION & PUMP INSTALLATION**

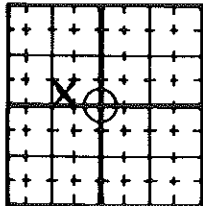
<b>A</b> 1 Contractor Name & Number: <u>ETTL Engineers &amp; Consultants Inc</u> C# <u>1401</u>					10 LOCATE WITH 'X' IN SECTION BELOW 
2 Driller Name & Number: <u>Thomas Cook</u> D# <u>2418</u>					
3 Pump Installer Name & Number: _____ P# _____					
4 Date Well Completed: <u>Nov. 4, 2009</u> New Well <input checked="" type="checkbox"/> Replace or Work-over <input type="checkbox"/>					
5 COUNTY <u>Benton</u>	6 FRACTION <u>SE 1/4 of NW 1/4 of 8</u>	7 SECTION <u>8</u>	8 TOWNSHIP <u>T18N</u>	9 RANGE <u>R33W</u>	
LONGITUDE 11 <u>94</u> ° <u>31</u> ' <u>26.9</u> "			LATITUDE 11 <u>36</u> ° <u>15</u> ' <u>7.0</u> "		

<b>B</b> 1 DESCRIPTION OF FORMATION: DEPTHS IN FEET	
B-3	FROM TO
Clayey Sand-Gray, Tan and Red	0 23
<i>ATTACH ADDITIONAL SHEETS IF NECESSARY</i>	
2 TOTAL DEPTH OF WELL	23 ft
3 DEPTHS TO WATER PRODUCING FORMATIONS.	11.5
4 STATIC WATER LEVEL	Ft below land surface
5 YIELD _____	gallons per <input type="checkbox"/> min <input type="checkbox"/> hr
6 DIAMETER OF BORE HOLE	6.5 IN

<b>C</b> PUMP REPORT <u>NA</u>	
1 TYPE PUMP: SUBMERSIBLE <input type="checkbox"/> TURBINE <input type="checkbox"/> JET <input type="checkbox"/>	
2 SETTING DEPTH: FEET	
3 BRAND NAME AND SERIAL NUMBERS:	
4 RATED CAPACITY	gallons per minute
5 TYPE LUBRICATION	
6 DROP PIPE OR COLUMN PIPE SIZE	
7 WIRE SIZE	
8 PRESSURE TANK . . . SIZE, MAKE, MODEL	
9 DATE OF INSTALLATION OR REPAIR	
10 Is there an abandoned water well on the property?	

<b>D</b> 1 LAND OWNER OR OTHER CONTACT PERSON:	
NAME <u>AEP</u>	
STREET ADDRESS <u>21797 SWEPCO Plant Road</u>	
CITY <u>Gentry, AR 72734</u>	
2 CASING	FROM 0' TO 13' W/ 2 "ID FROM TO W/ "ID
TYPE CASING: <u>PVC</u>	
3 SCREEN	TYPE: <u>PVC</u> DIA <u>2"</u> SLOT/GA <u>0.010"</u>
	SET FROM <u>13</u> FT TO <u>23</u> FT
	TYPE: DIA SLOT/GA
	SET FROM FT TO FT
4 GRAVEL PACK	FROM 10 FT TO 23 FT
5 BACK FILLED WITH: <u>Bentonite</u>	FROM 2 FT TO 10 FT
6 SEALED WITH: <u>Cement</u>	FROM 0 FT TO 2 FT
	FROM FT TO FT
7 DISINFECTED WITH: <u>NA</u>	
8 USE OF WELL:	
DOMESTIC <input type="checkbox"/>	COMMERCIAL <input type="checkbox"/>
IRRIGATION <input type="checkbox"/>	MONITOR <input checked="" type="checkbox"/>
LIVESTOCK/POULTRY <input type="checkbox"/>	TEST WELL <input type="checkbox"/>
OIL/GAS SUPPLY <input type="checkbox"/>	SEMI-PUBLIC <input type="checkbox"/>
PUBLIC SUPPLY <input type="checkbox"/>	OTHER <input type="checkbox"/>
(A/C HEATPUMP TYPE WELLS)	
SOURCE <input type="checkbox"/>	RETURN <input type="checkbox"/>
CLOSED LOOP <input type="checkbox"/>	
9 (For A/C only) Will system also be used for purposes other than Heating or Air Conditioning?	If yes, name use: yes <input type="checkbox"/> no <input type="checkbox"/>
10 (For A/C open-loop only) Into what medium is water returned?	
11 REMARKS	<u>Flush mount surface completion</u>
12 SIGNED <u>Thomas Cook</u>	DATE <u>12-9-09</u>

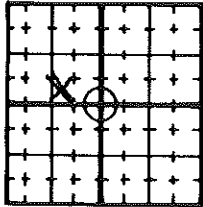

**STATE OF ARKANSAS  
REPORT ON WATER WELL CONSTRUCTION & PUMP INSTALLATION**

<b>A</b> 1 Contractor Name & Number: <u>ETTL Engineers &amp; Consultants Inc</u> C# <u>1401</u>					10 LOCATE WITH 'X' IN SECTION BELOW 
2 Driller Name & Number: <u>Thomas Cook</u>			D# <u>2418</u>		
3 Pump Installer Name & Number: _____ P# _____					
4 Date Well Completed: <u>Nov. 4, 2009</u> New Well <input checked="" type="checkbox"/> Replace or Work-over <input type="checkbox"/>					
5 COUNTY <u>Benton</u>	6 FRACTION <u>SE ¼ of NW ¼ of 8</u>	7 SECTION <u>8</u>	8 TOWNSHIP <u>T18N</u>	9 RANGE <u>R33W</u>	
11 LONGITUDE <u>94 ° 31 ' 27.8 "</u>			11 LATITUDE <u>36 ° 15 ' 8.9 "</u>		

<b>B</b> 1 DESCRIPTION OF FORMATION:      DEPTHS IN FEET		
B-4	FROM	TO
Clayey Sand-Tan, Gray and Red	0	23
ATTACH ADDITIONAL SHEETS IF NECESSARY		
2 TOTAL DEPTH OF WELL	23	ft
3 DEPTHS TO WATER PRODUCING FORMATIONS.	23	
4 STATIC WATER LEVEL	7.5	Ft below land surface
5 YIELD _____	gallons per	min <input type="checkbox"/> hr <input type="checkbox"/>
6 DIAMETER OF BORE HOLE	6.5	IN

<b>C</b> PUMP REPORT <u>NA</u>	
1 TYPE PUMP:    SUBMERSIBLE <input type="checkbox"/> TURBINE <input type="checkbox"/> JET <input type="checkbox"/>	
2 SETTING DEPTH:      FEET	
3 BRAND NAME AND SERIAL NUMBERS:	
4 RATED CAPACITY _____	gallons per minute
5 TYPE LUBRICATION	
6 DROP PIPE OR COLUMN PIPE SIZE	
7 WIRE SIZE	
8 PRESSURE TANK . . . SIZE, MAKE, MODEL	
9 DATE OF INSTALLATION OR REPAIR	
10 Is there an abandoned water well on the property?	

<b>D</b> 1 LAND OWNER OR OTHER CONTACT PERSON:	
NAME	<u>AEP</u>
STREET ADDRESS	<u>21797 SWEPCO Plant Rd.</u>
CITY	<u>Gentry, AR72734</u>
2 CASING	FROM <u>0'</u> TO <u>13'</u> W/ <u>2</u> "ID
	FROM _____ TO _____ W/ _____ "ID
TYPE CASING: <u>PVC</u>	
3 SCREEN	TYPE: <u>PVC</u> DIA <u>2"</u> SLOT/GA <u>0.010</u>
	SET FROM <u>13</u> FT TO <u>23</u> FT
	TYPE: _____      DIA _____      SLOT/GA _____
	SET FROM _____ FT TO _____ FT
4 GRAVEL PACK	FROM <u>11</u> FT TO <u>23</u> FT
5 BACK FILLED WITH: <u>Bentonite</u>	FROM <u>3</u> FT TO <u>11</u> FT
6 SEALED WITH: <u>Cement</u>	FROM <u>0</u> FT TO <u>3</u> FT
	FROM _____ FT TO _____ FT
7 DISINFECTED WITH: <u>NA</u>	
8 USE OF WELL:	
DOMESTIC	<input type="checkbox"/> COMMERCIAL <input type="checkbox"/>
IRRIGATION	<input type="checkbox"/> MONITOR <input checked="" type="checkbox"/>
LIVESTOCK/POULTRY	<input type="checkbox"/> TEST WELL <input type="checkbox"/>
OIL/GAS SUPPLY	<input type="checkbox"/> SEMI-PUBLIC <input type="checkbox"/>
PUBLIC SUPPLY	<input type="checkbox"/> OTHER <input type="checkbox"/>
(A/C HEATPUMP TYPE WELLS)	
SOURCE	<input type="checkbox"/> RETURN <input type="checkbox"/>
CLOSED LOOP	<input type="checkbox"/>
9 (For A/C only) Will system also be used for purposes other than Heating or Air Conditioning?	If yes, name use: _____      yes <input type="checkbox"/> no <input type="checkbox"/>
10 (For A/C open-loop only) Into what medium is water returned?	
11 REMARKS	<u>Flush mount surface completion</u>
12 SIGNED	DATE
	<u>12-9-09</u>

**ATTACHMENT C**  
**DESIGN DRAWINGS**



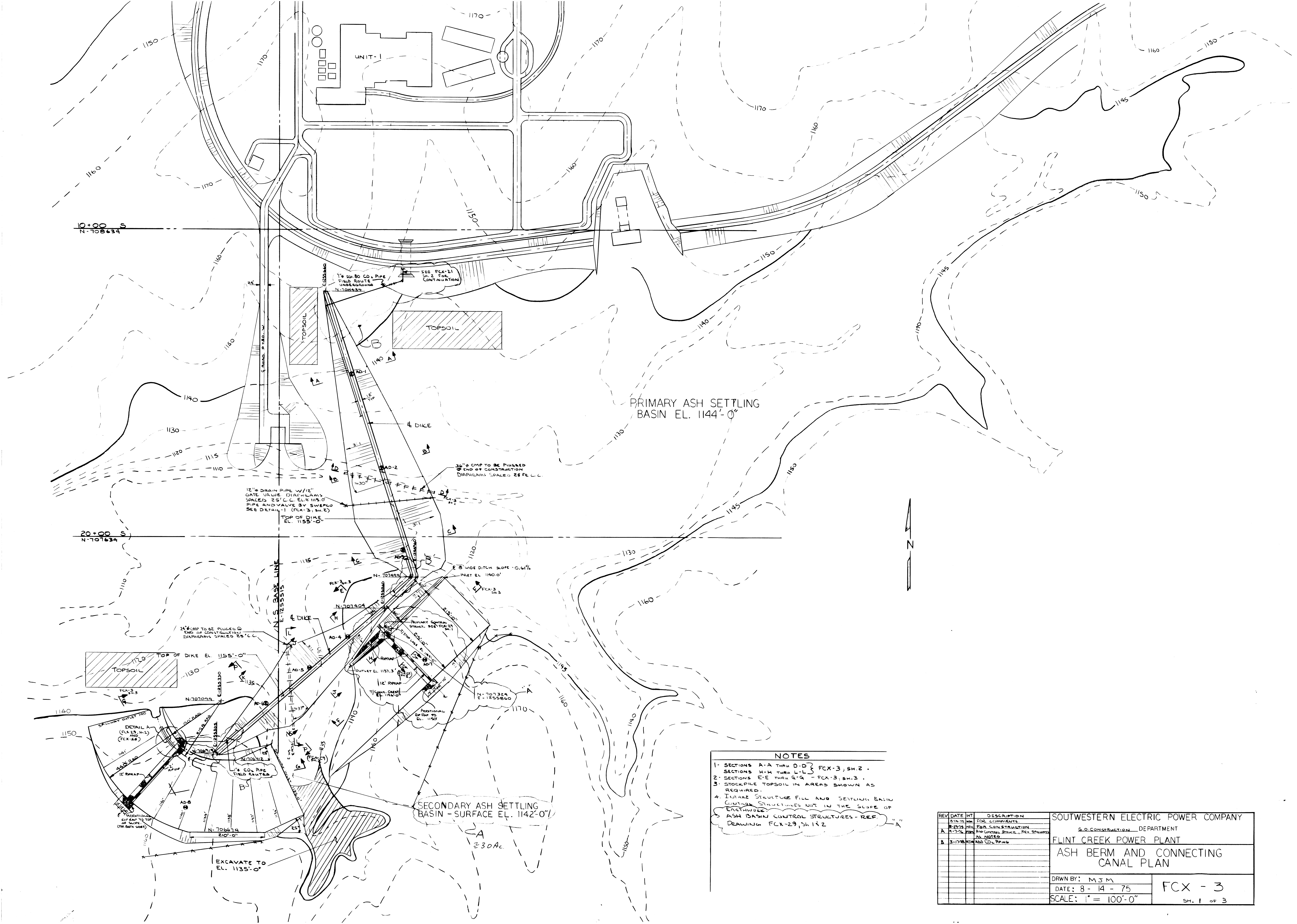

PRIMARY ASH SETTLING  
BASIN EL. 1144'-0"

SECONDARY ASH SETTLING  
BASIN - SURFACE EL. 1142'-0"

- NOTES**
- 1- SECTIONS A-A THRU D-D } FCX-3, SH. 2
  - 2- SECTIONS H-H THRU L-L } FCX-3, SH. 3
  - 3- STOCKPILE TOPSOIL IN AREAS SHOWN AS REQUIRED.
  - 4- FUTURE STRUCTURE FILL AND SETTLING BASIN CONTROL STRUCTURES NOT IN THE SCOPE OF THIS DRAWING.
  - 5- ASH BASIN CONTROL STRUCTURES - REF. DRAWING FCX-29, SH. 1 & 2

REV.	DATE	INT.	DESCRIPTION	SOUTHWESTERN ELECTRIC POWER COMPANY
1	8-14-75	MM	FOR COMMENTS	S.E. CONSTRUCTION DEPARTMENT FLINT CREEK POWER PLANT
2	8-14-75	MM	FOR CONSTRUCTION	
A	8-14-75	MM	FOR GENERAL STRUCT. & FCX SPACING	ASH BERM AND CONNECTING CANAL PLAN
B	8-14-75	MM	ADD COL. R.P.M.G.	
DRWN BY: M.J.M.				FCX - 3
DATE: 8-14-75				
SCALE: 1" = 100'-0"				SH. 1 OF 3

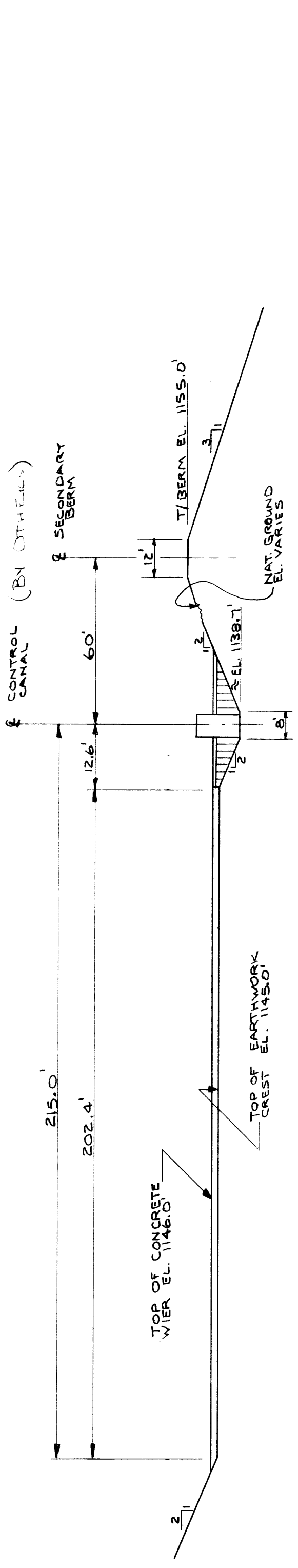

SECTION "E-E"  
PRIMARY CONTROL CANAL AND  
SPILLWAY

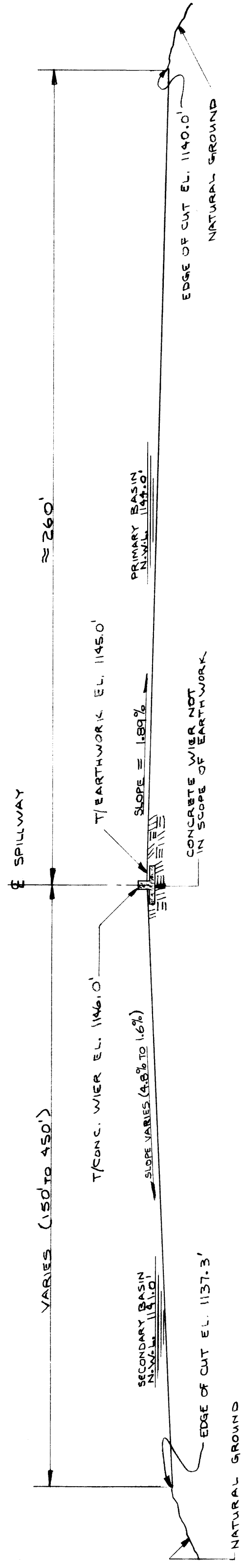

SECTION "E-E"

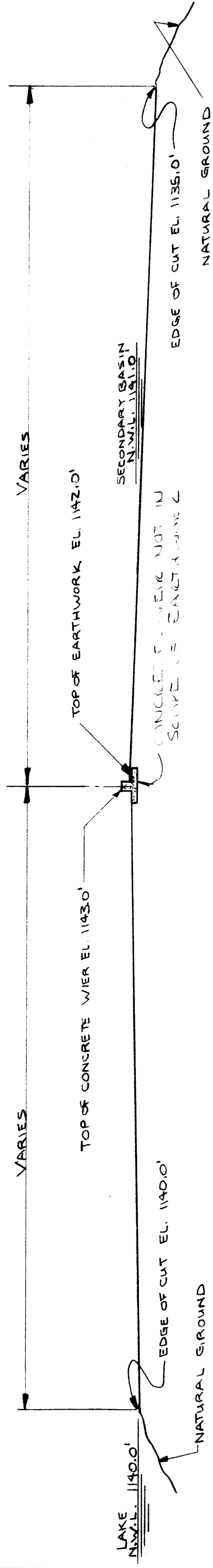

SECTION "G-G"

DATE	3.17.78	FOR CONSTRUCTION
REV.		
DATE		
BY		
SUBJECT	ASH POND SPILLWAY SECTIONS	
FLINT CREEK POWER PLANT		
SOUTHWESTERN ELECTRIC POWER CO.		
S.O. CONSTRUCTION		DEPARTMENT
		DIVISION
APPROVED		ENGR. IN CHARGE
APPROVED		DIV. SUPT.
APPROVED		CHIEF ENGR.
DRAWN BY	M.S.V.	CHECKED
DATE	B-18-75	DRAWING NO.
SCALE: 1" = 30'		FCX - 3
		SH. 3

SHEET



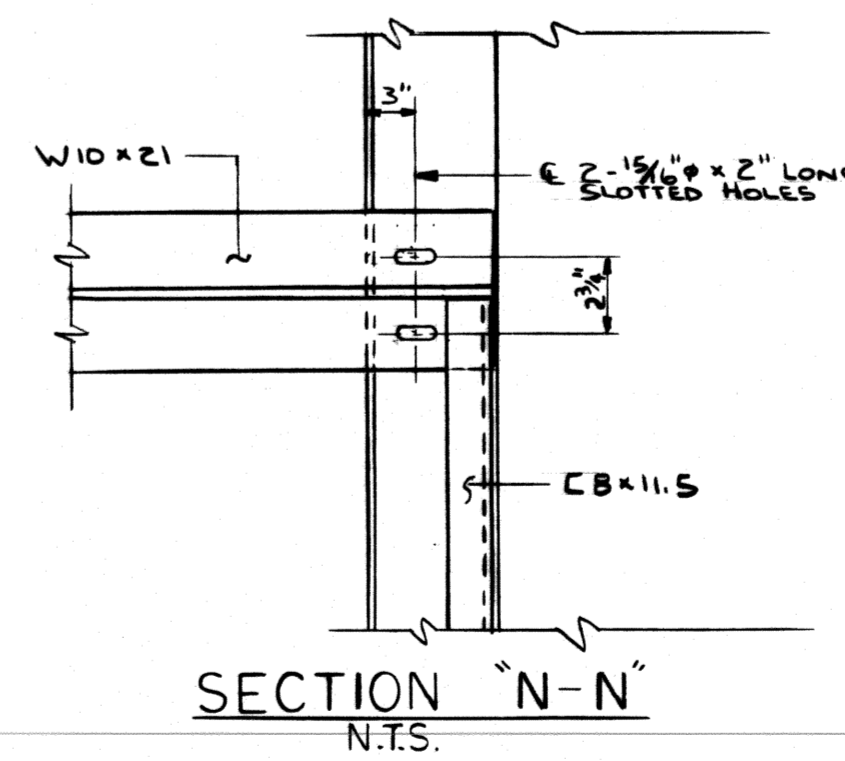
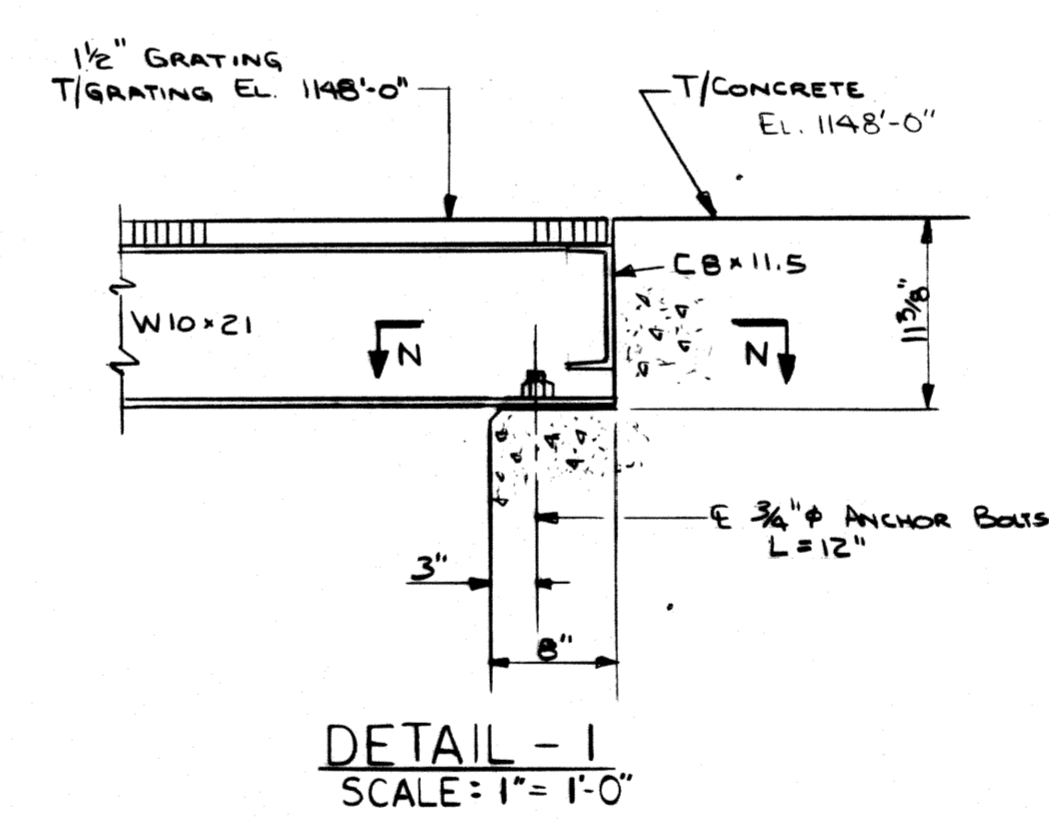
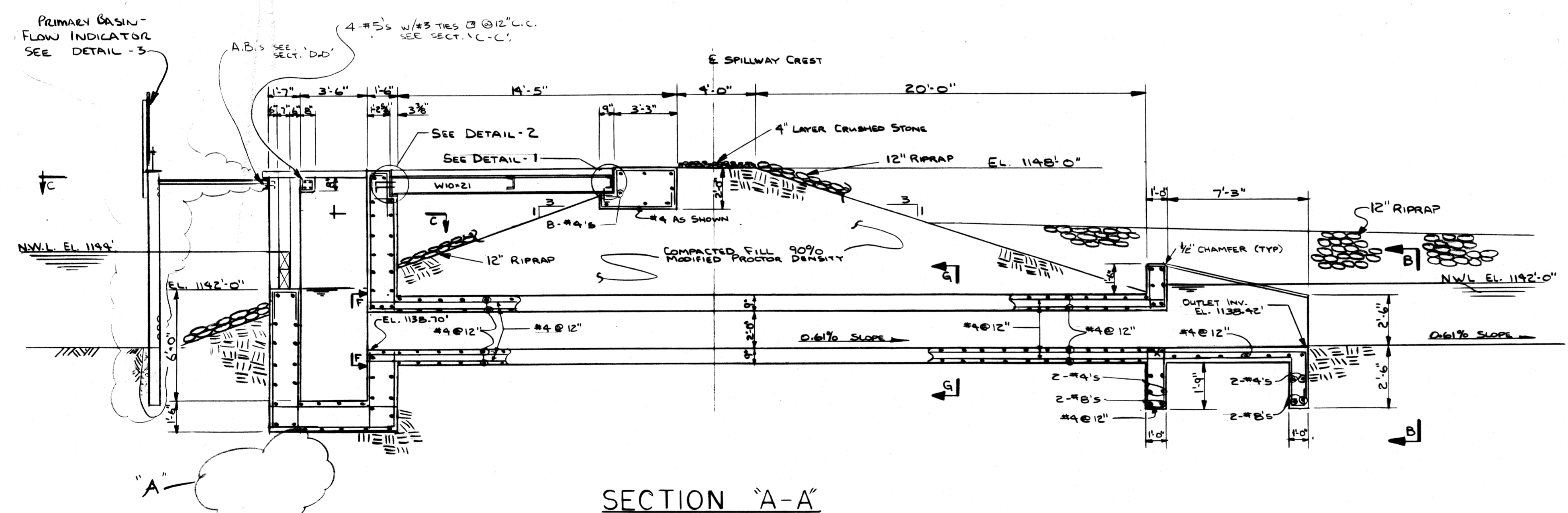
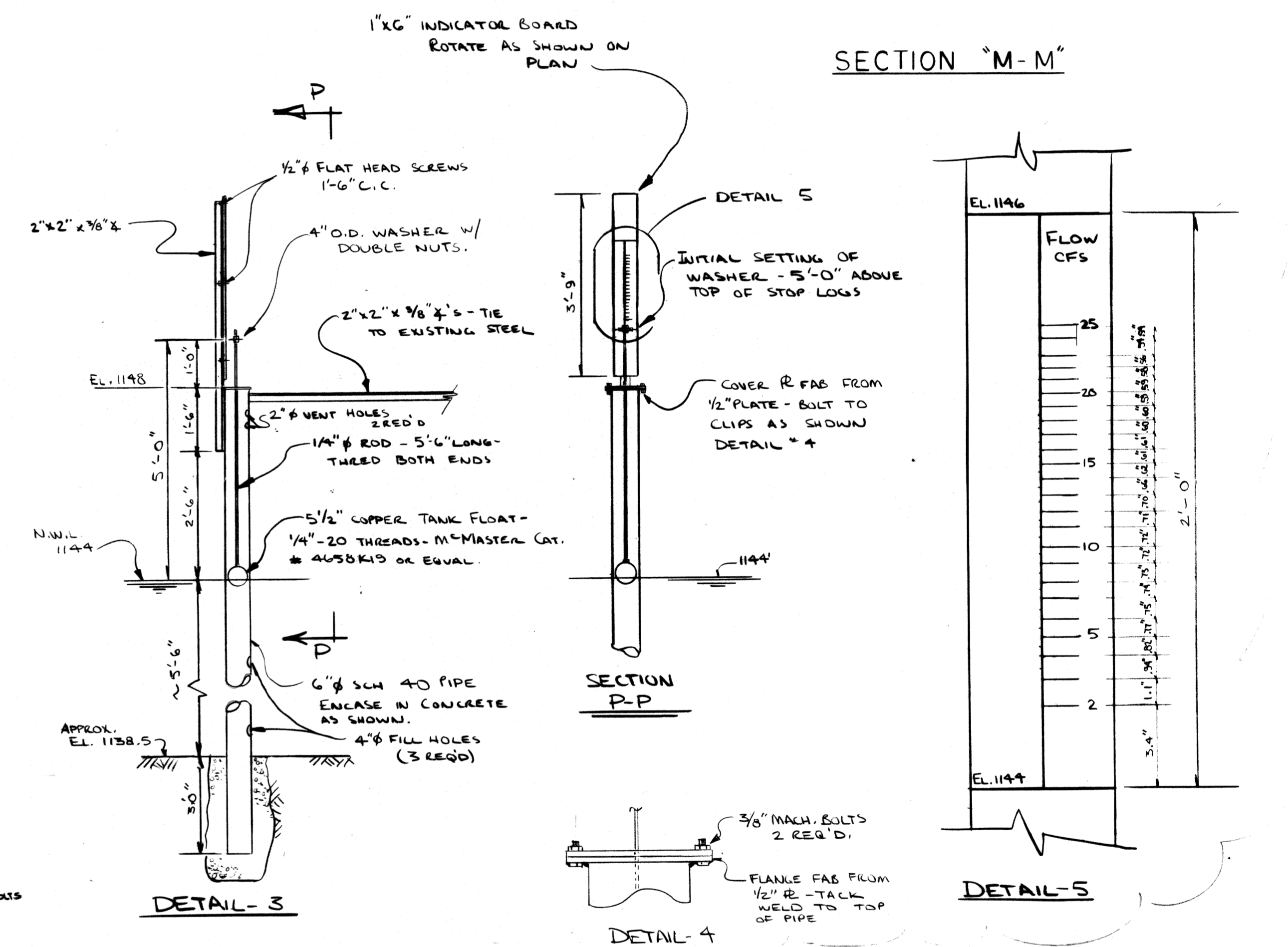
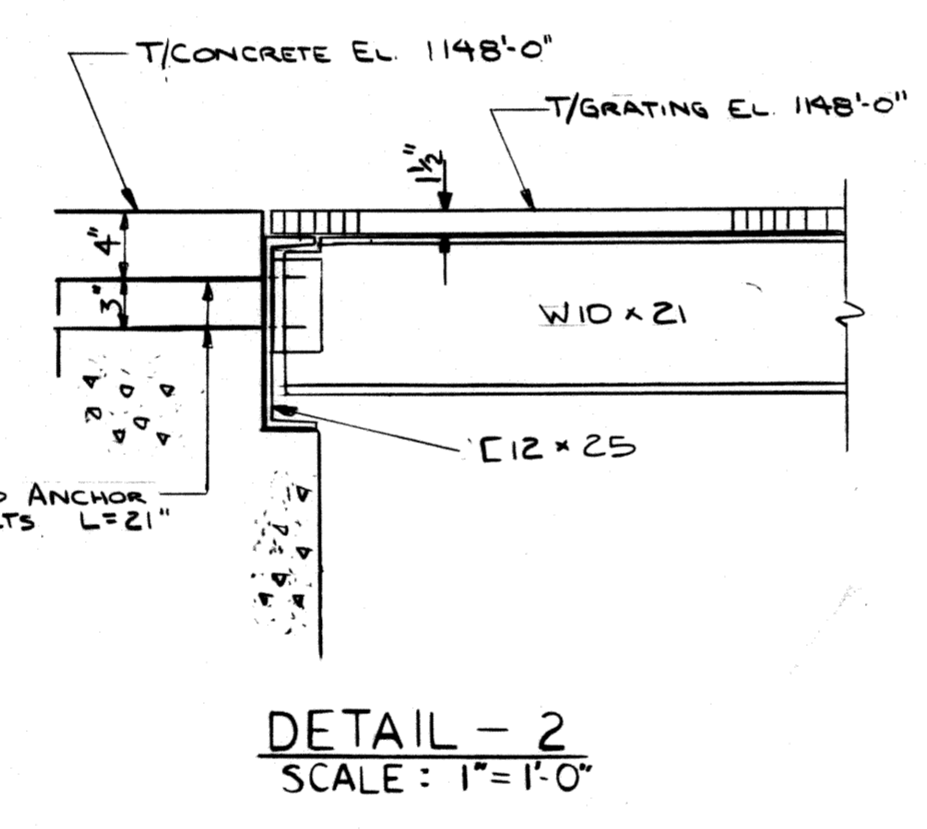
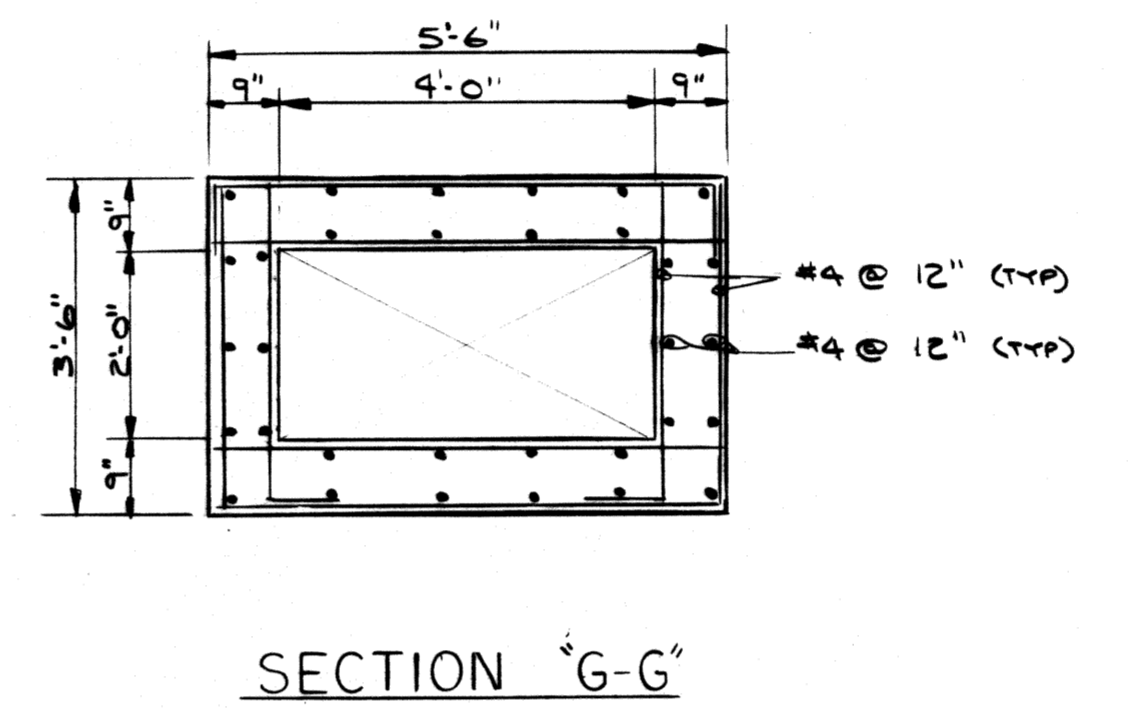
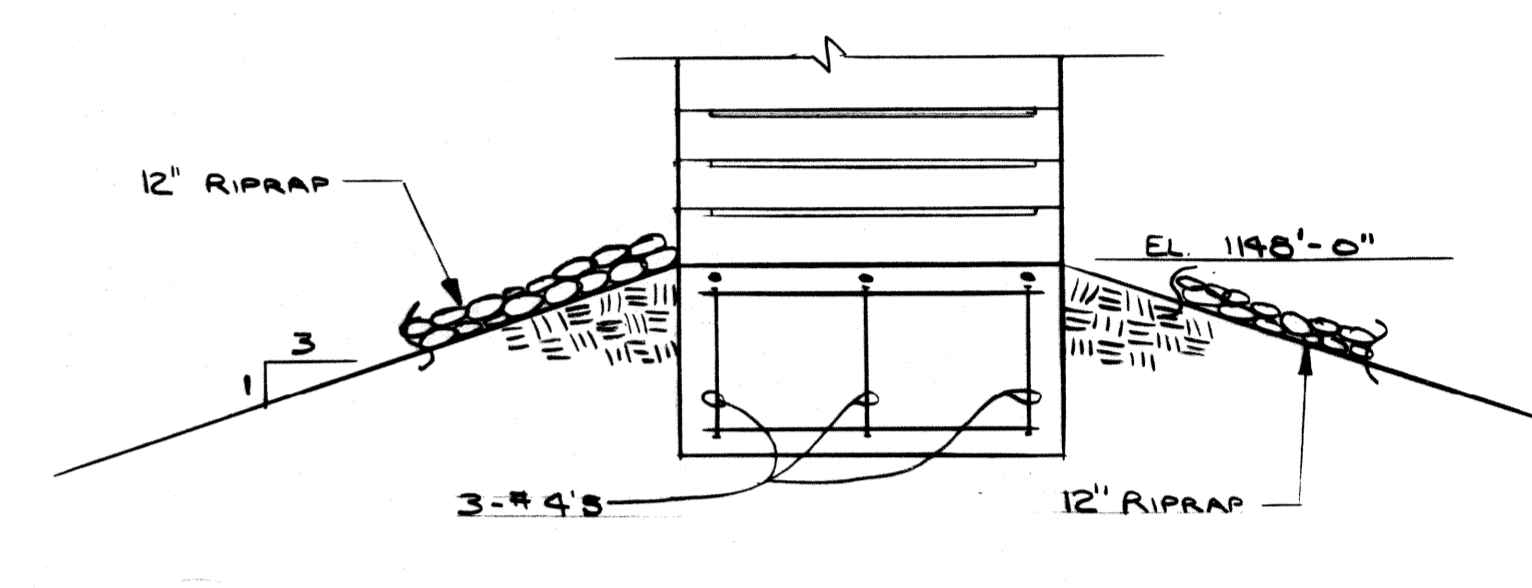
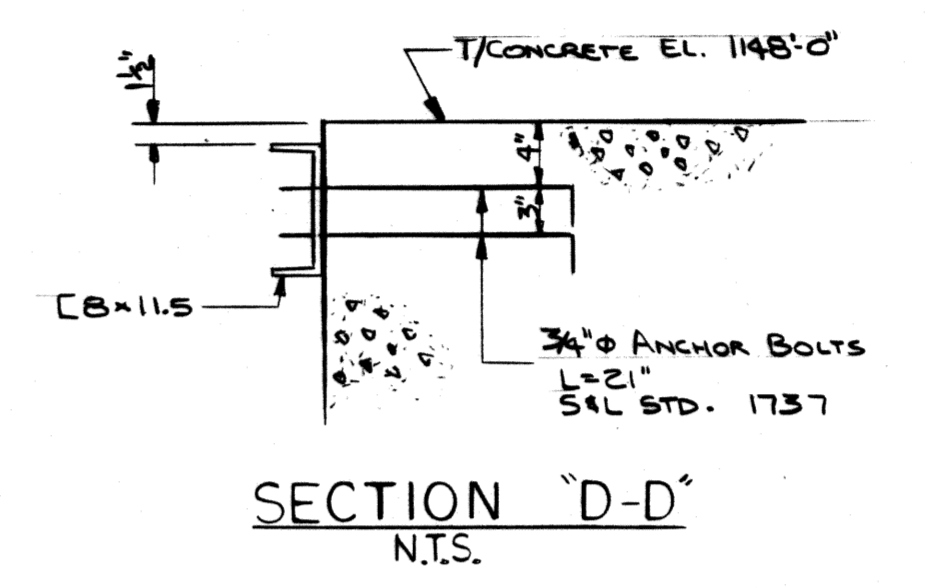
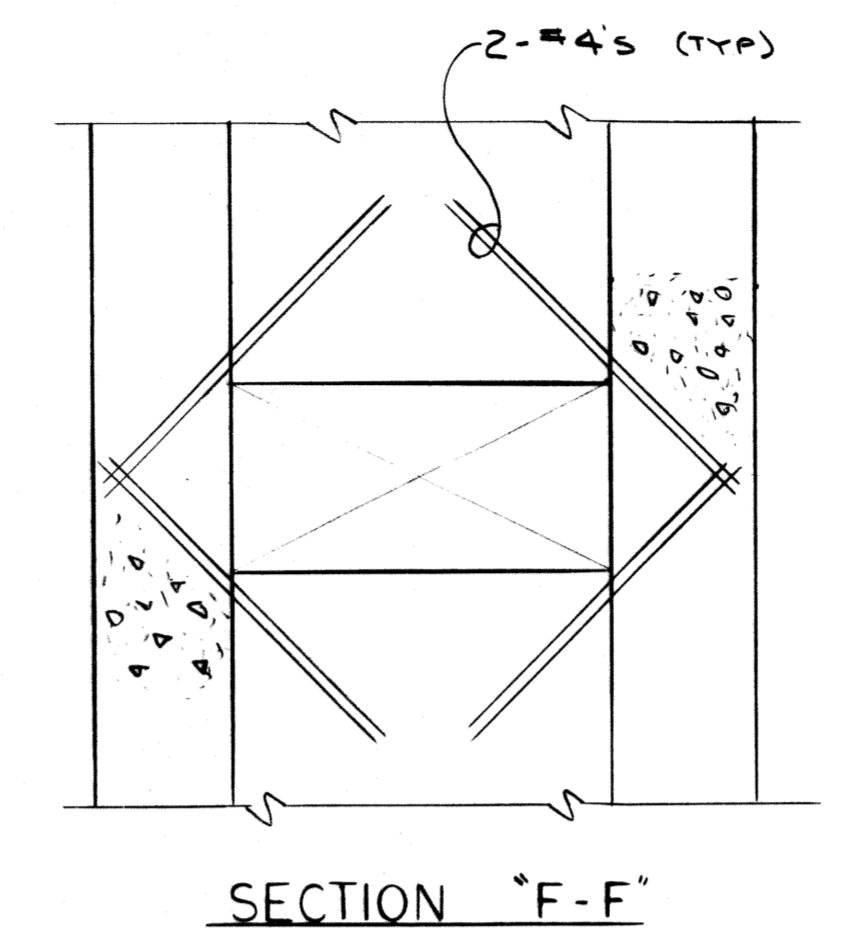
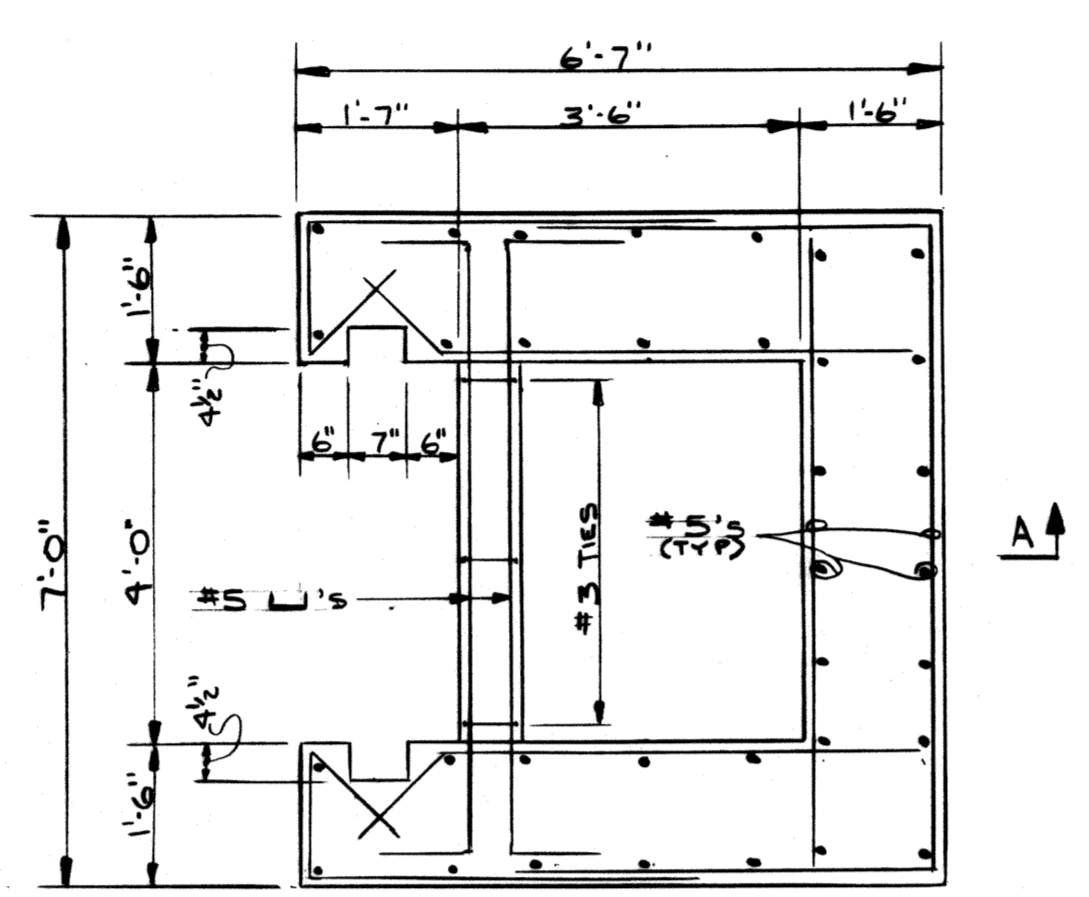
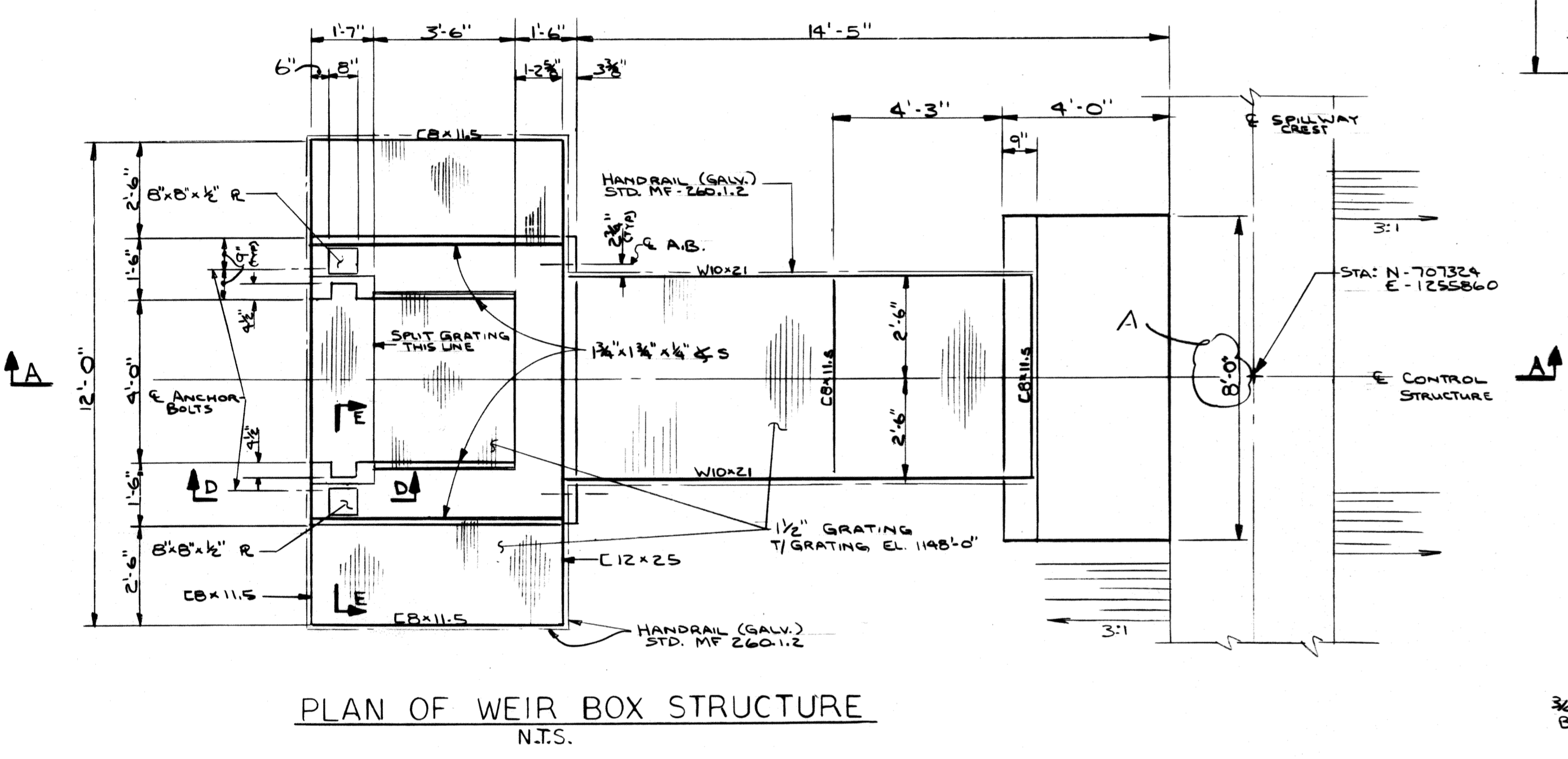
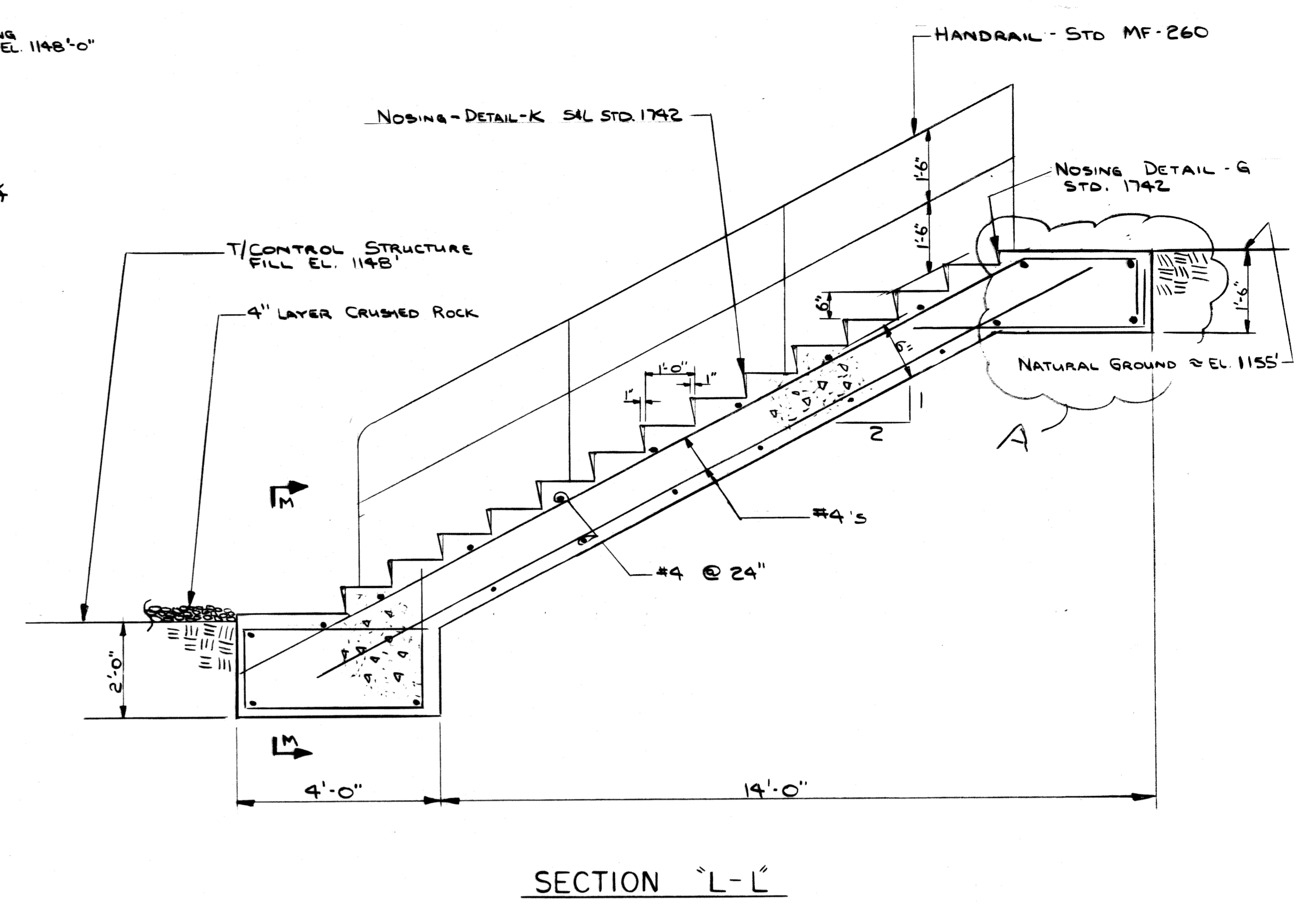
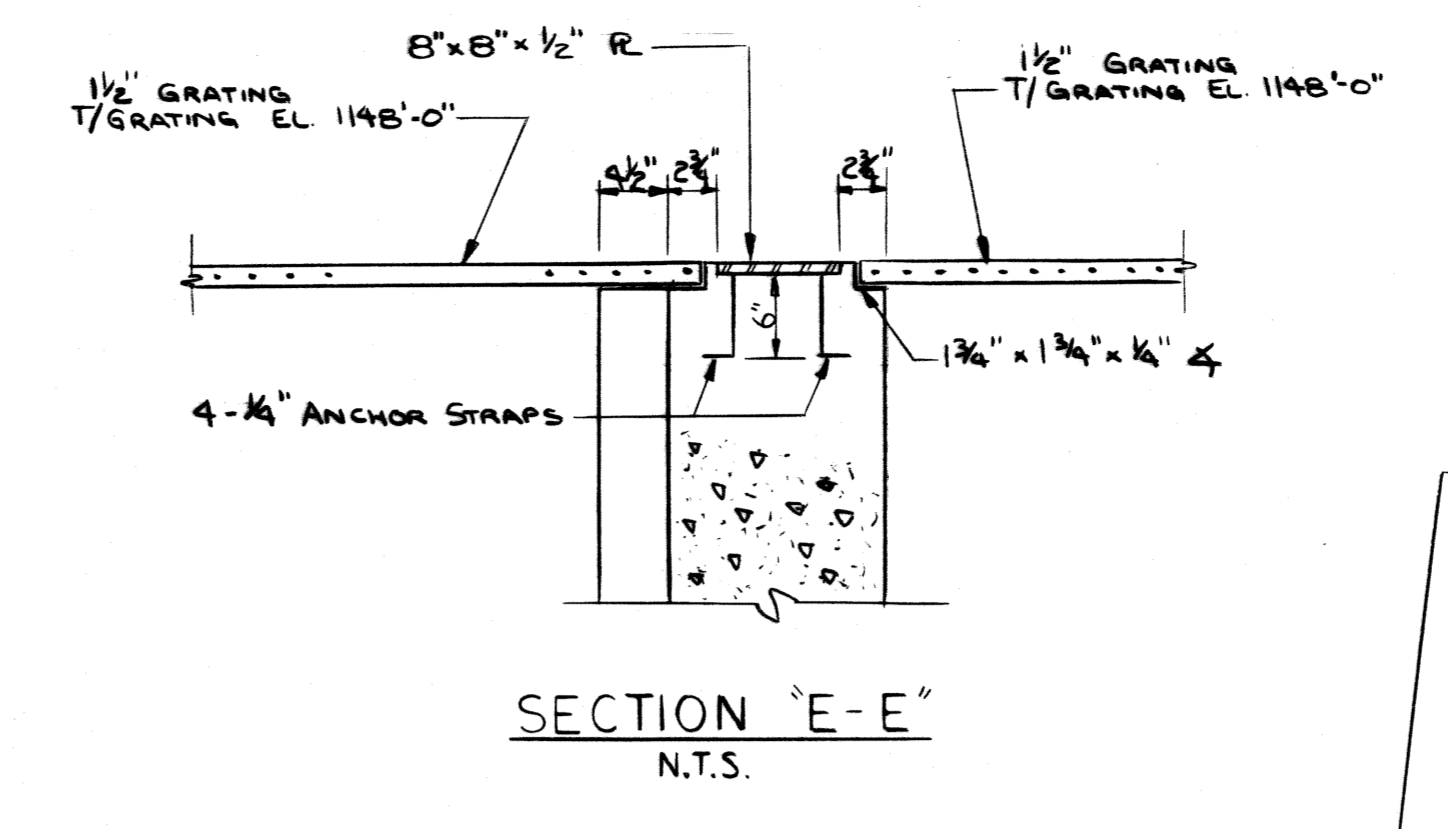
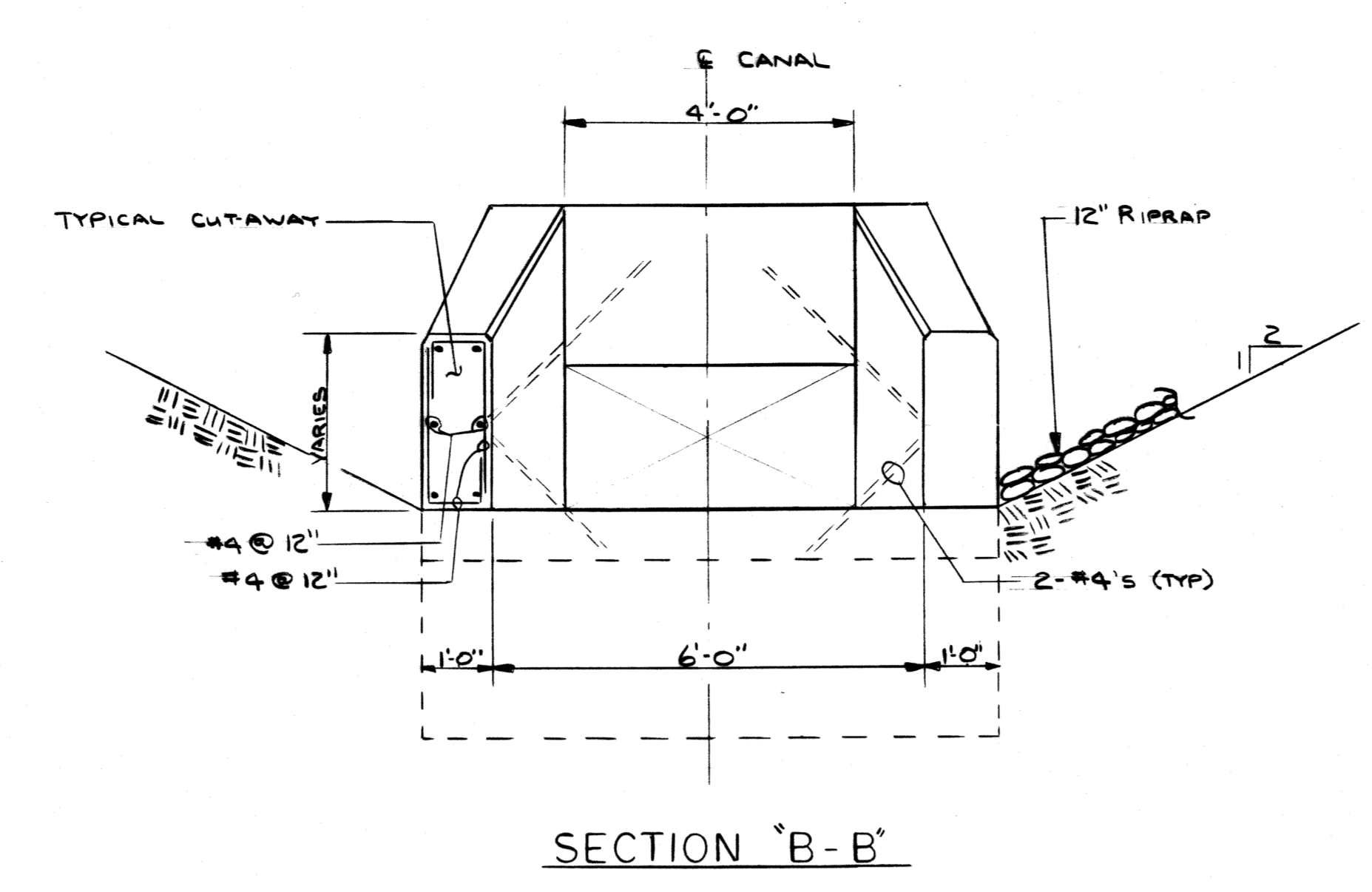
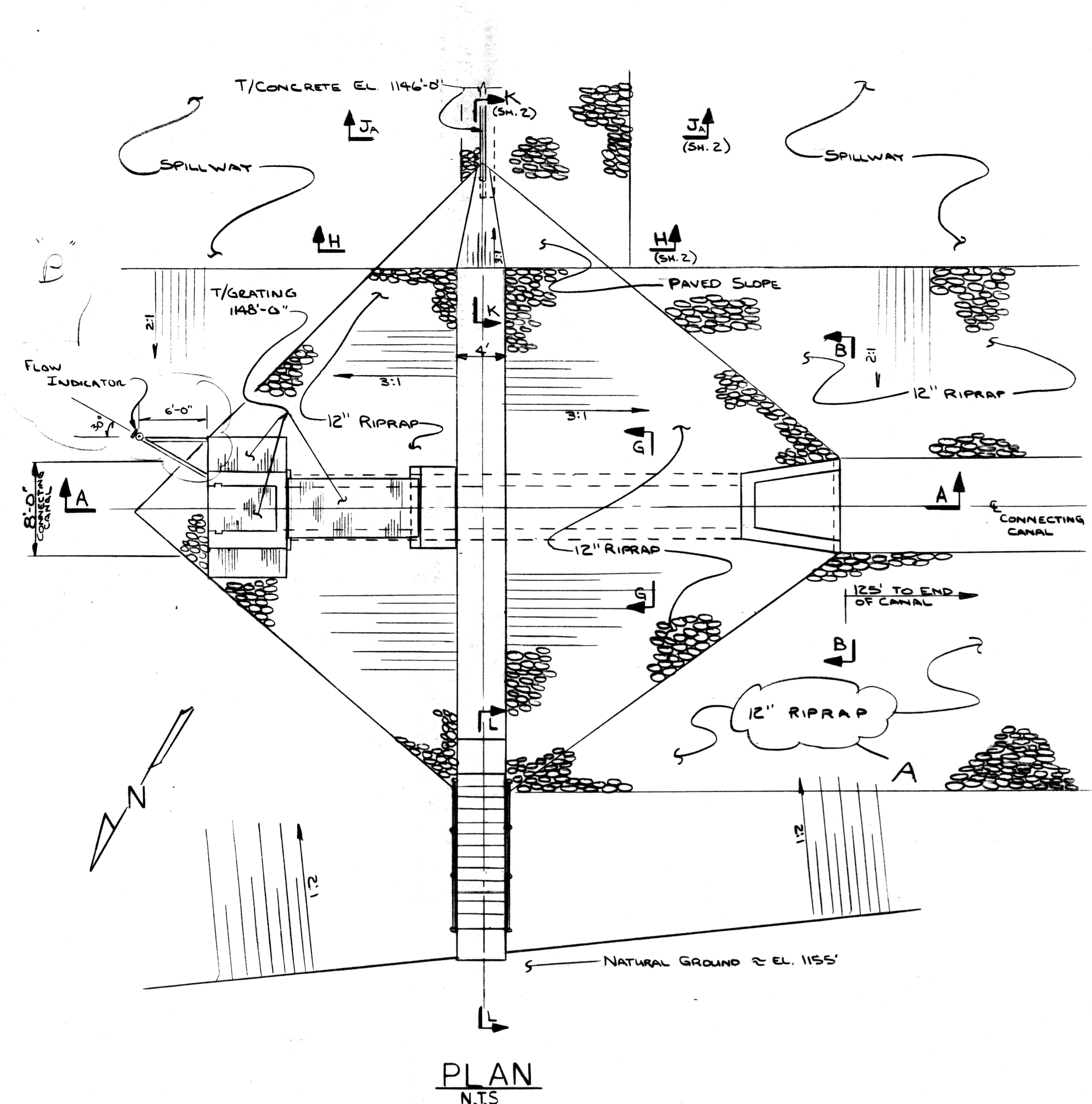

- NOTES:
- 1) ALL COMPACTED FILL INCLUDING TAMPING @ BOX SIDES, BY SITEWORK CONTRACTOR.
  - 2) ALL RIP RAP & CRUSHED ROCK FURNISHED BY SWEPCO & SPREAD BY SITEWORK CONTRACTOR.
  - 3) ALL ELEVATION, EXCEPT AS NOTED, BY CONTROL STRUCTURE CONTRACTOR. ALL MATERIAL & CONCRETE WORK BY C.S. CONTRACTOR.
  - 4) REFERENCE FOR FLOAT INDICATOR TO BE MADE FROM TOP OF STOP LOGS. SEAL ALL CORNERS OF STOP LOGS W/ BITUMASTIC COATING.

REV.	DATE	BY	SUBJECT
A	4-7-76	MM	FOR COMMENTS
B	5-7-76	MM	FOR CONSTRUCTION
C	11/1/76	AM	ADD FLOW INDICATOR

SOUTHWESTERN ELECTRIC POWER CO.  
POWER - CONSTRUCTION DEPARTMENT  
FLINT CREEK POWER PLANT  
ASH STORAGE BASIN  
CONTROL STRUCTURES

CKD BY: \_\_\_\_\_  
DRWN BY: MARTIN  
DATE: 4-6-76  
SCALE: 1/2"=1'-0" OR AS NOTED

DRWG NO. FCX-29 SH-1

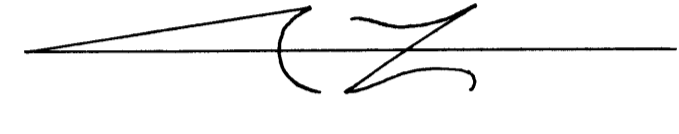
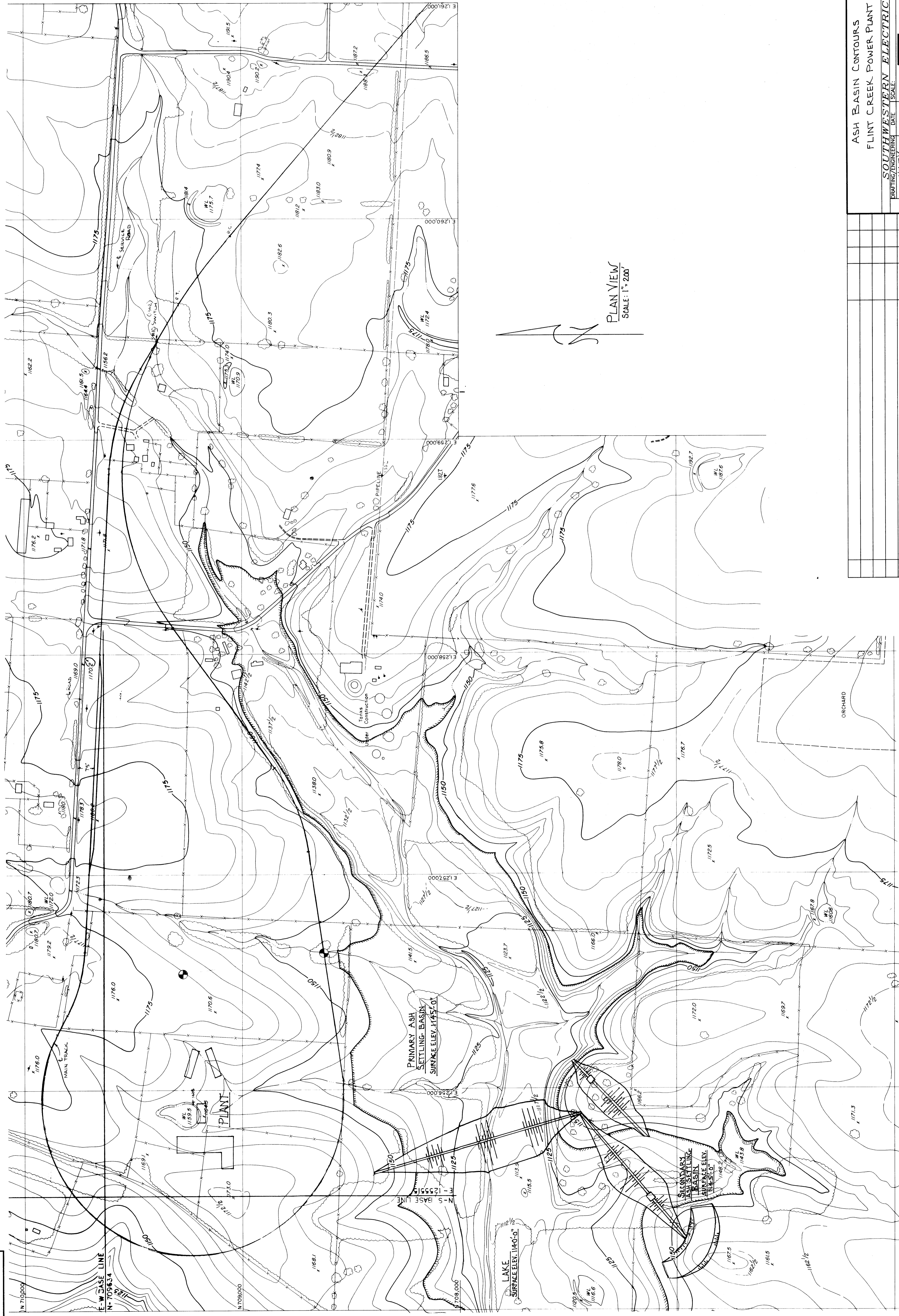

PLAN VIEW  
SCALE: 1" = 200'

REV	DATE	DR	BY	APP	DESCRIPTION
	11-18-05	1/1			RELEASED FOR INFORMATION

  

SOUTHWESTERN ELECTRIC POWER CO.	
DWG. NO.	FCX-96
DATE	11-18-05
DR.	1/1
ENG.	
APP.	

  

ASH BASIN CONTOURS FLINT CREEK POWER PLANT	
SOUTHWESTERN ELECTRIC POWER CO.	
REV. NO.	1
SHT.	1 of 1



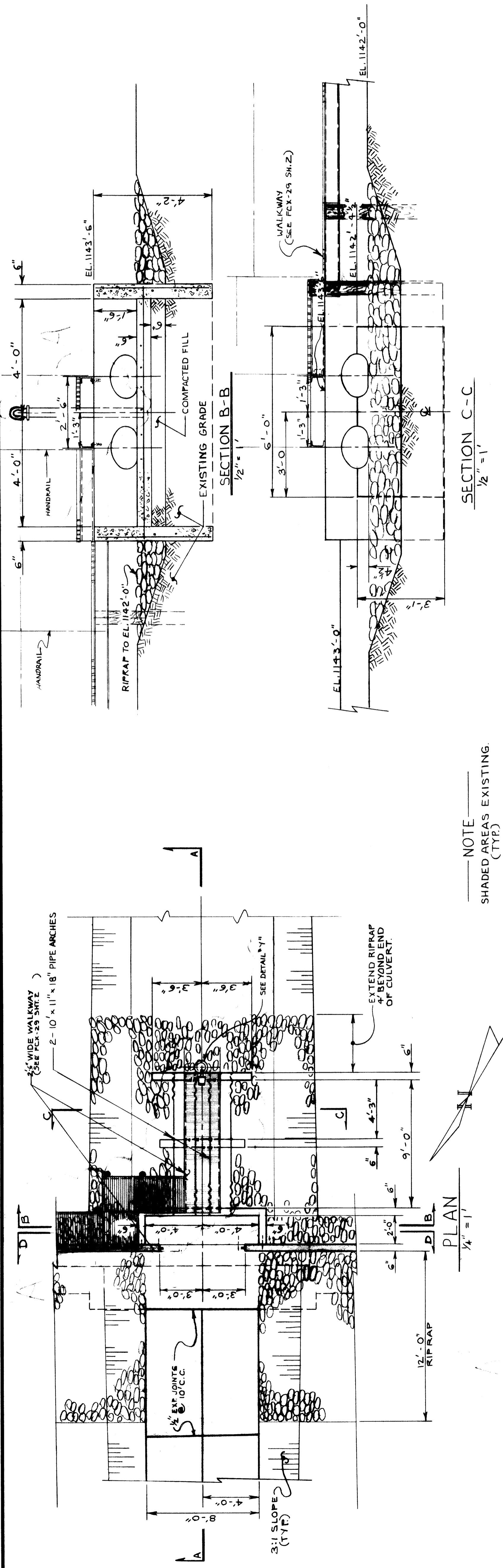

NOTE  
SHADED AREAS EXISTING.  
(TYP)

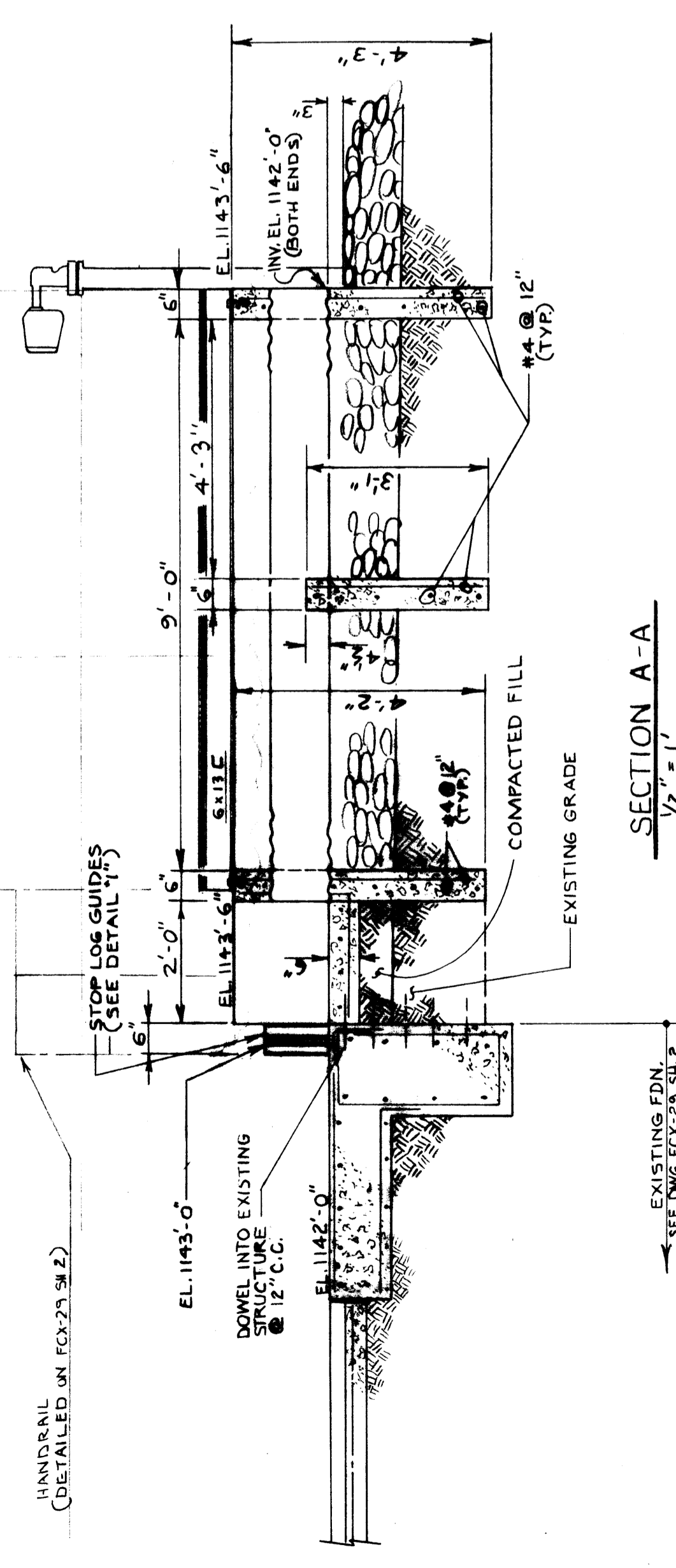

EXISTING FDN.  
SEE DWG. FCX-29, SH. 2

SECTION A-A  
1/2" = 1'

DETAIL "Y"  
N.T.S.

DETAIL "X"  
N.T.S.

DETAIL "Z"  
N.T.S.

REV. DATE BY

A	5/18/77	JP	ADDED WALKWAY + INSTRUMENT
	9-7-77	BP	FOR CONSTRUCTION

SUBJECT  
SECONDARY BASIN OUTLET  
CONTROL STRUCTURE FOR CO<sub>2</sub>  
INJECTION.  
FLINT CREEK POWER PLANT  
Southwestern Electric Power Company  
CONSTRUCTION/POWER DEPARTMENT  
LA. DIVISION

APPROVED BY: ENGR. IN CHARGE  
APPROVED BY: DIV. SUPT.  
APPROVED BY: CHIEF ENGR.  
DRAWN BY: B.P.  
TRACED BY:  
DATE: 8-22-77  
DWG. NO.: FCX-56  
SCALE: AS NOTED

NOTES:  
1) SHADED AREA DENOTES EXISTING WORK.  
2) 2-10" x 11'-x 18" PIPE ARCHES W/ WELDED SEAMS AND 3/8" x 1/2" CORRUGATION.

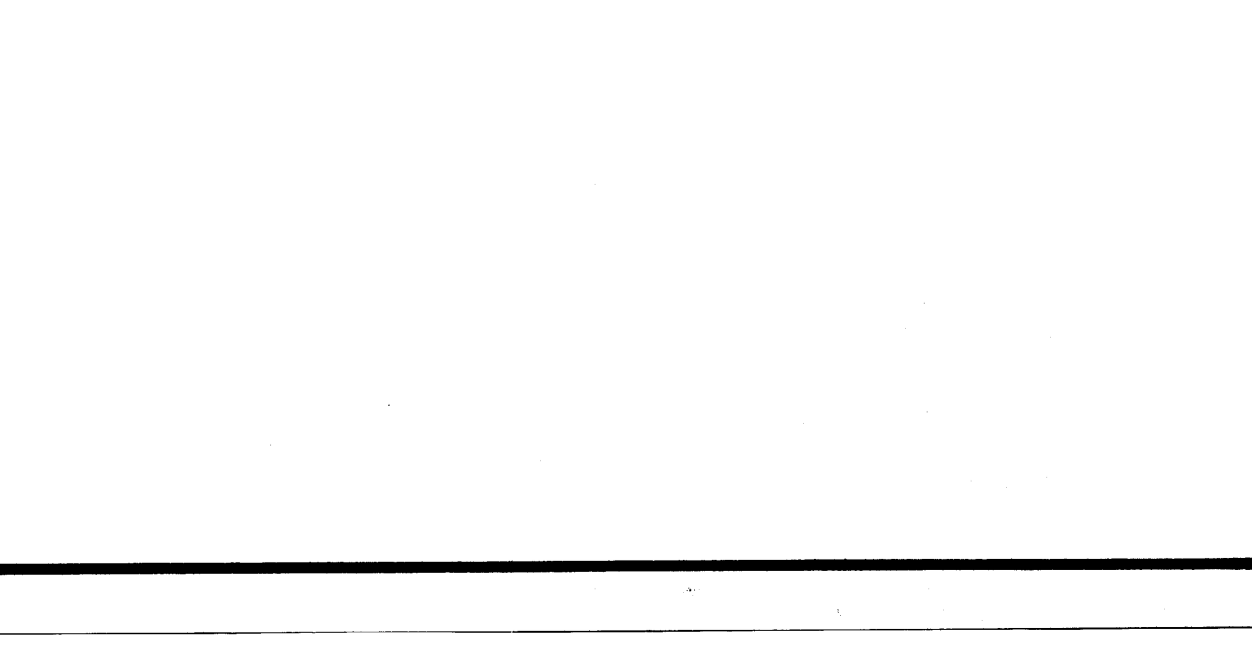
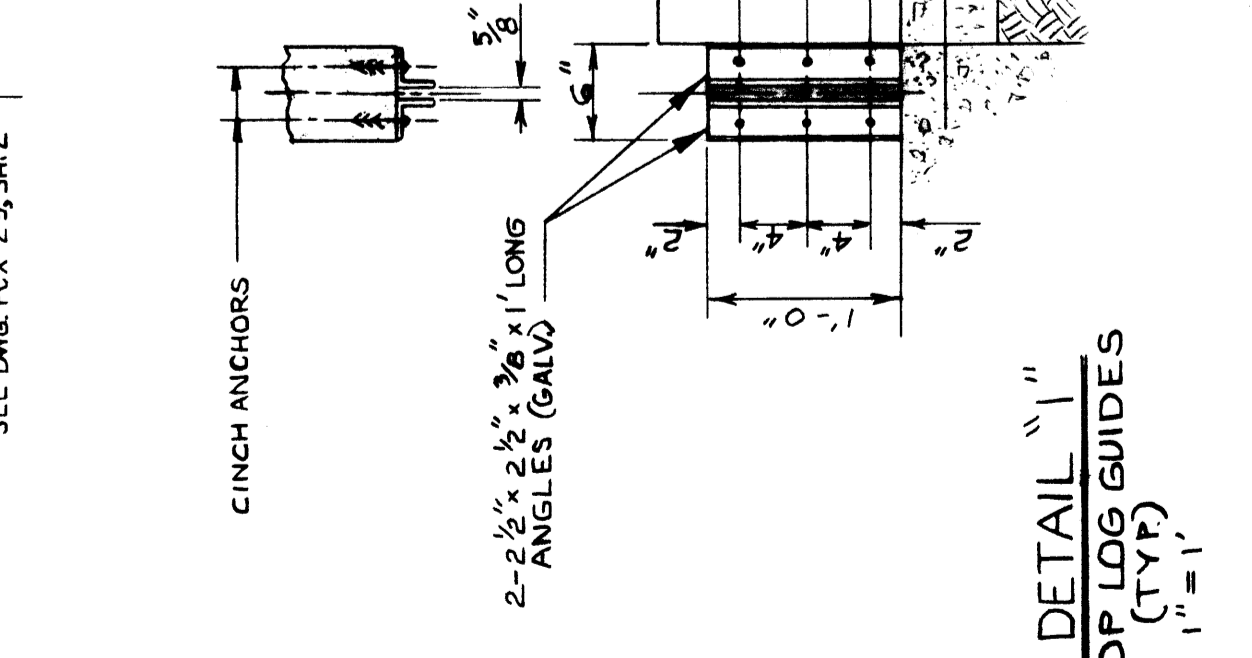
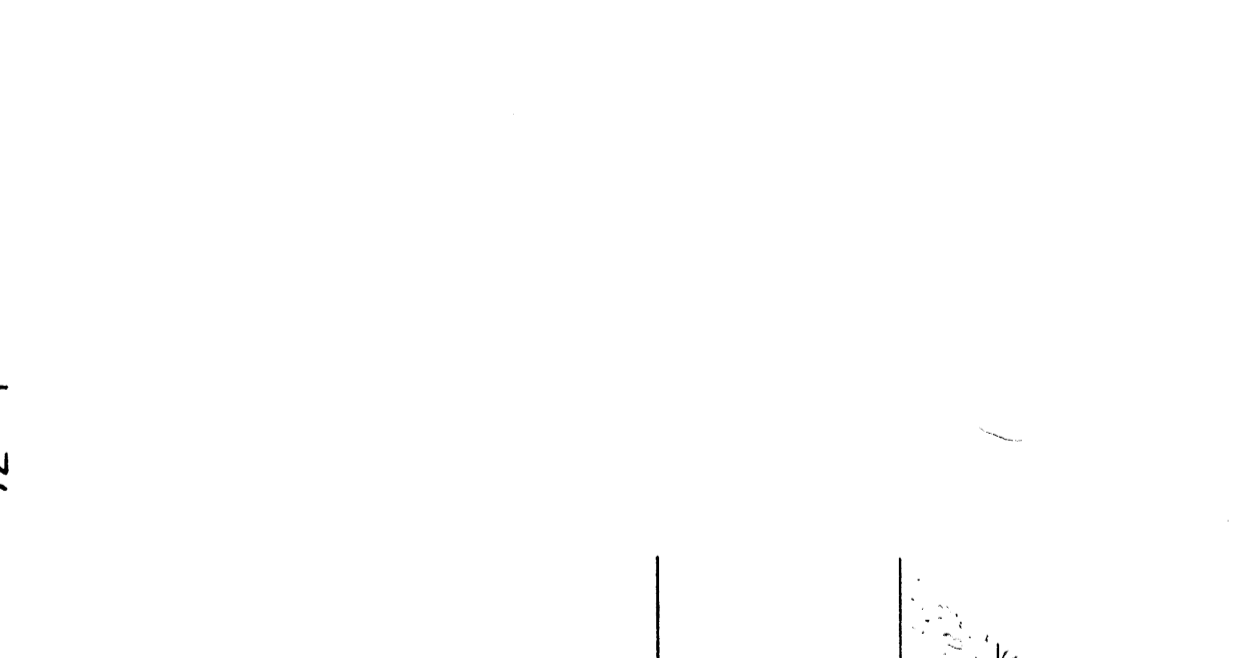
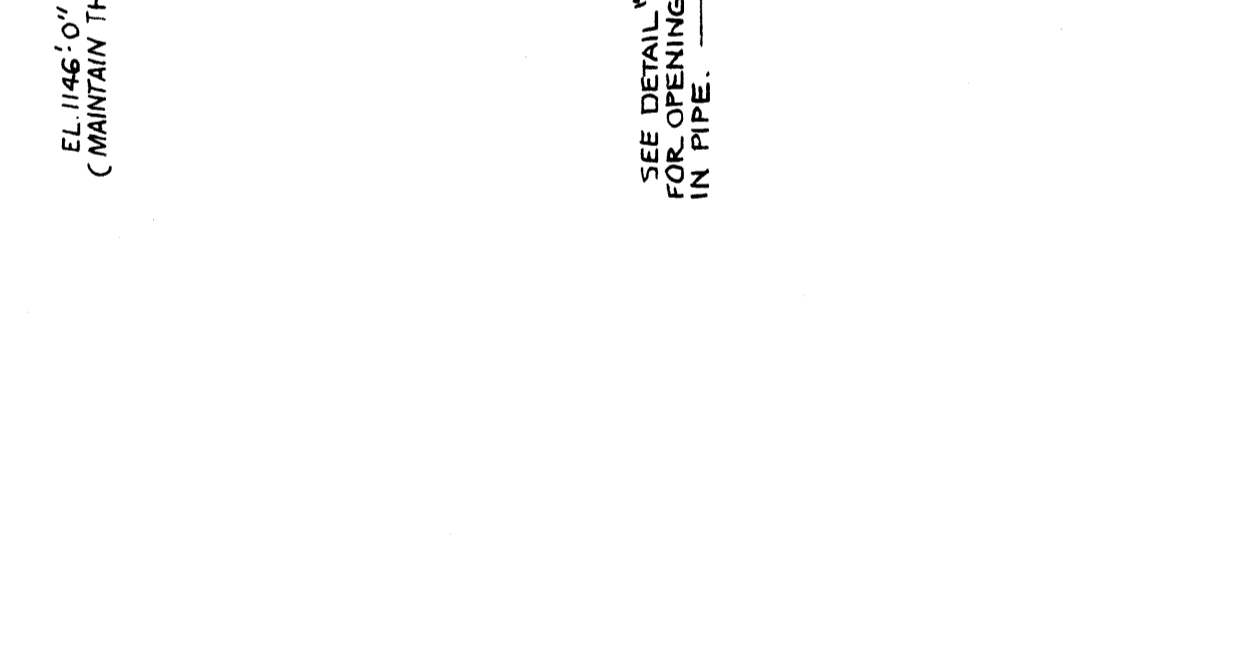
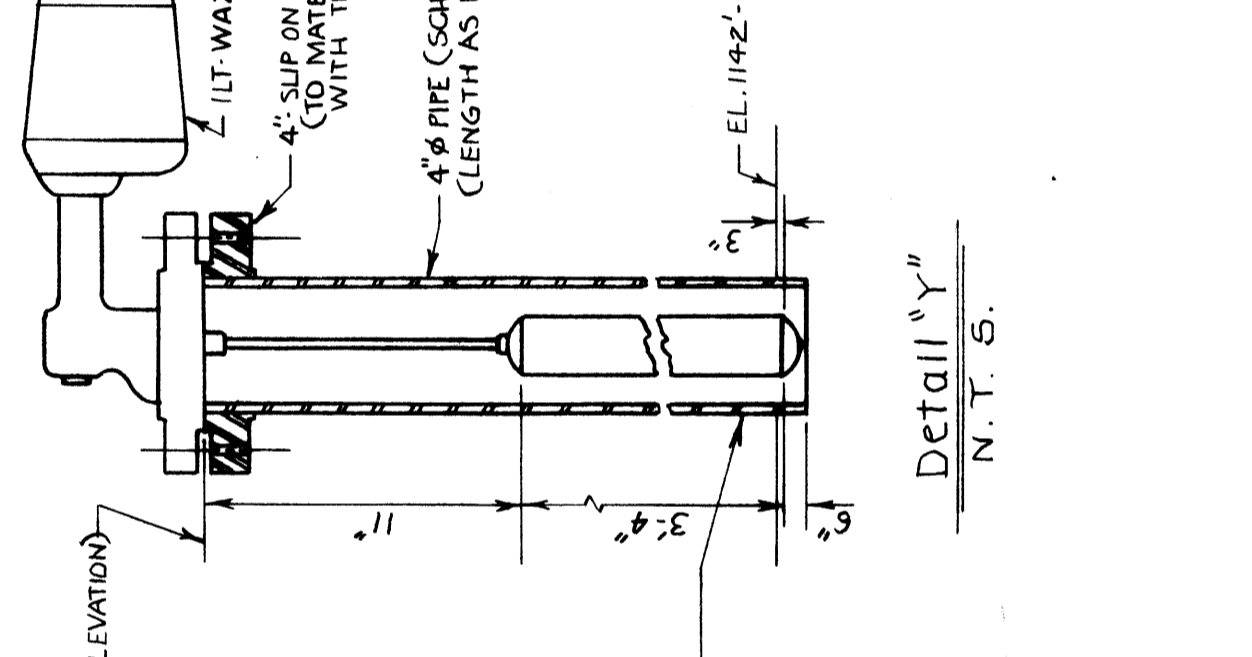
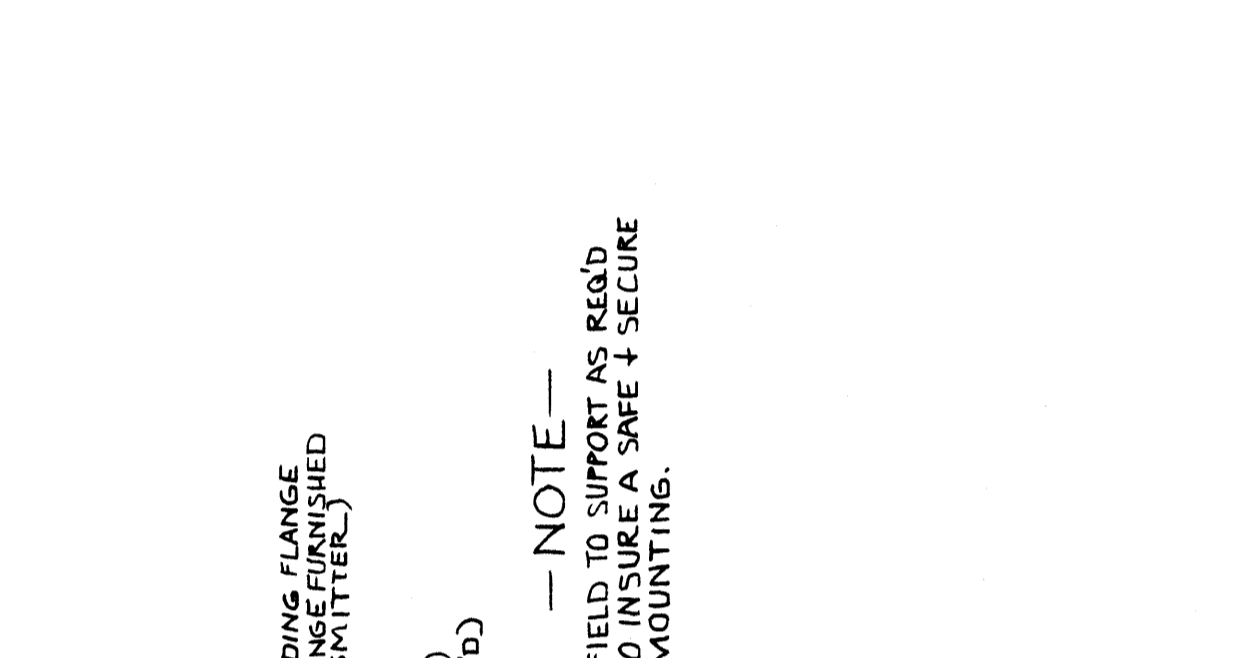
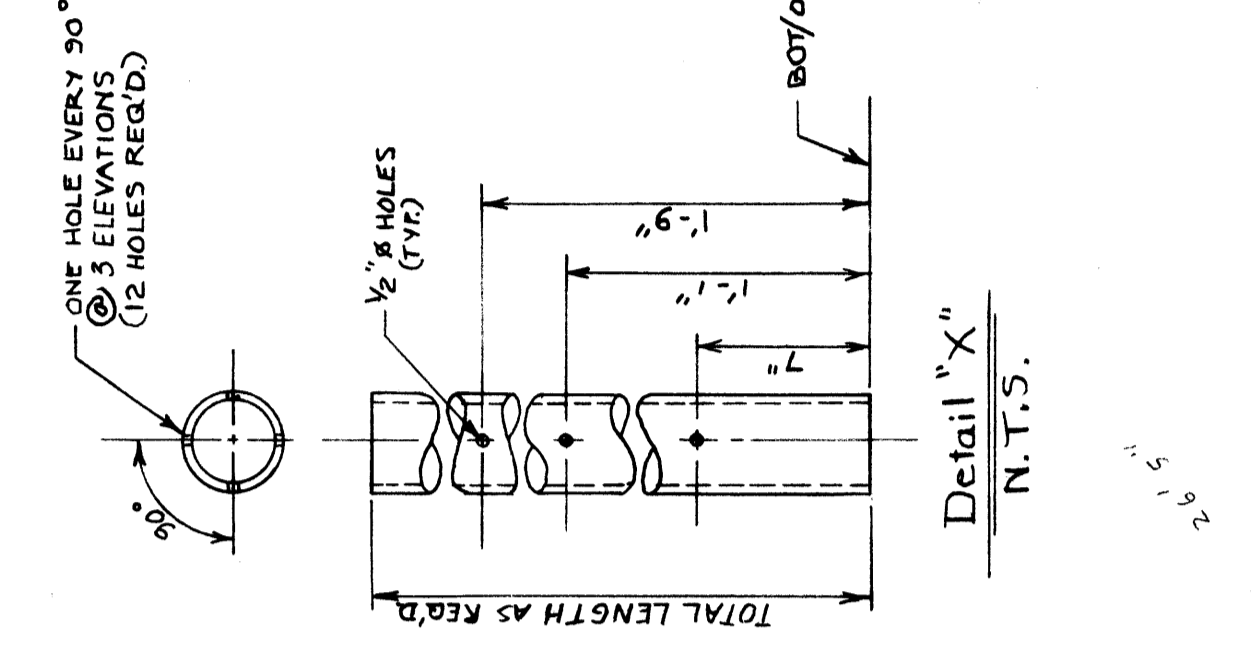

**ATTACHMENT D**

**INSTRUMENTATION LOCATION MAP**

C:\GIS\American Electric Power\09390068 Dam and Dike Inspections\2011 PROJECTS

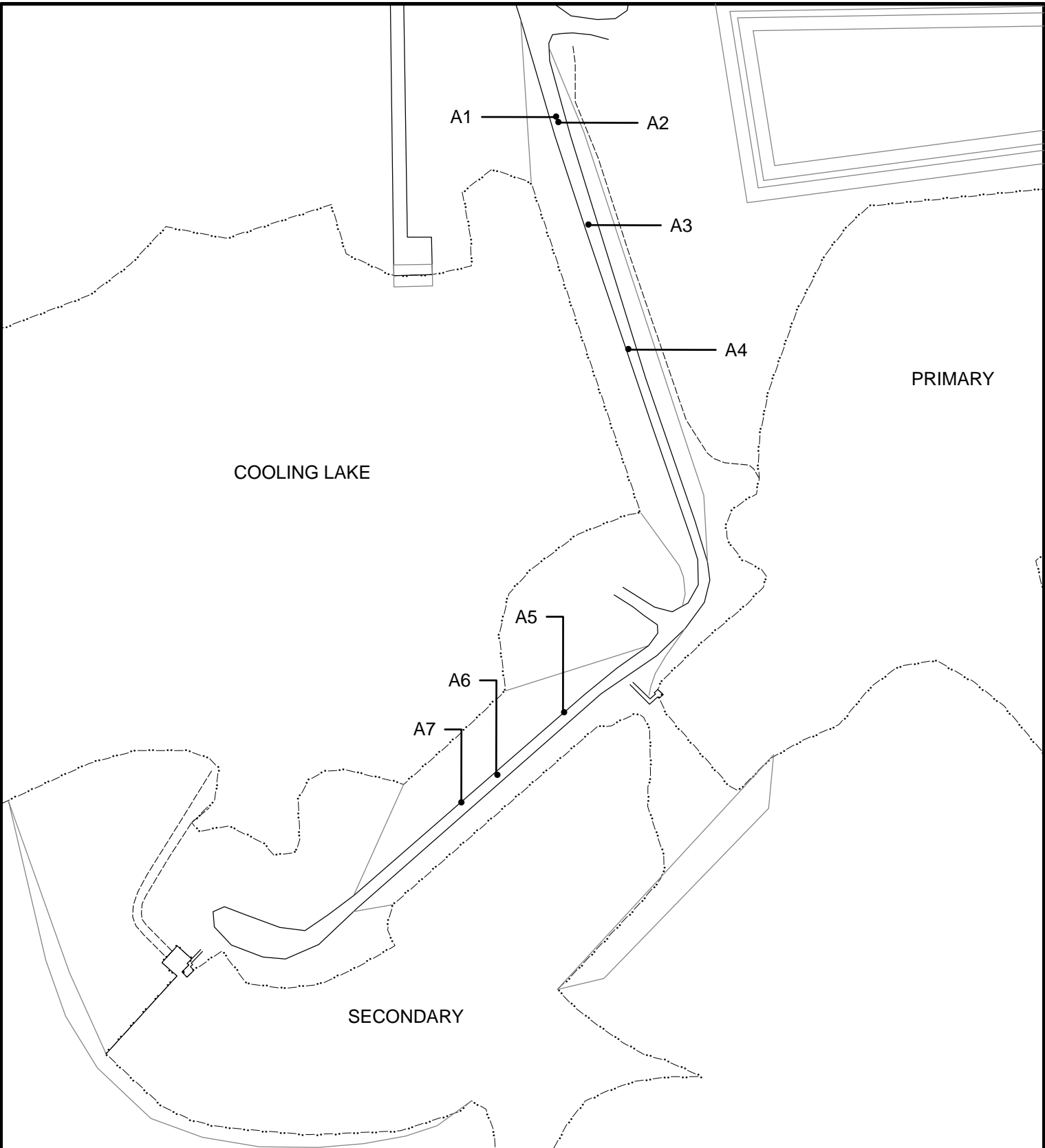

COOLING LAKE

PRIMARY

SECONDARY

A1 ——— A2

————— A3

————— A4

————— A5

————— A6

————— A7



PLACEMENT OF DAM COMPONENTS AND IDENTIFIED DEFICIENCIES IS APPROXIMATE

PROJECT		AMERICAN ELECTRIC POWER LITTLE FLINT CREEK GENERATING STATION			
TITLE		LOCATION OF PIEZOMETERS			
PROJECT No.		09390068.11		FILE No. LFC-FIG	
DESIGN	XXX	XXX	SCALE: 1:2,400	REV. 0	
GIS	MTC	11/03/2011	<b>2</b>		
CHECK	RIO	12/05/2011			
REVIEW	RIO	12/05/2011			



**ATTACHMENT E**

**CONSTRUCTION SPECIFICATIONS**

CONTRACT  
SOUTHWESTERN ELECTRIC POWER COMPANY  
MACHEN CONSTRUCTION COMPANY  
FLINI CREEK POWER PLANT  
SITE WORK  
SEPTEMBER 4, 1974

OWNER'S COPY

SOUTHWESTERN ELECTRIC POWER COMPANY

Shreveport, Louisiana

This agreement made this 18th day of February, 1975, by and between Machen Construction Company, (hereinafter called the "Contractor"), Little Rock, Arkansas, and Southwestern Electric Power Company, (hereinafter called the "Owner").

WITNESSETH:

- (1) This contract is to be performed by Machen Construction Company (Contractor), within the State of Arkansas, and the parties hereto covenant and agree that it is and shall be construed as an Arkansas Contract, in accordance with the laws of the State of Arkansas, and the parties hereto shall have all the rights, privileges, remedies and immunities applicable under the laws of said State.
- (2) Contractor agrees to complete the plant site clearing, grubbing and grading, railroad bed construction, ash pit dike construction and related work, and excavation and embankment for the Generating Plant area, as set forth in the Specifications, at Owner's Flint Creek Power Plant site located in Benton County, approximately two and one-half (2-1/2) miles southwest of Gentry, Arkansas.
- (3) Contractor agrees to do the work in accordance with the Specifications and Drawings attached hereto and made a part hereof. Any changes in the Specifications or Drawings will not be a part of this contract until ordered in writing by the Owner.
- (4) Contractor agrees to furnish in good operating condition all construction equipment, tools and supplies necessary to complete the work in the time set forth in paragraph 6.
- (5) Contractor covenants, represents, and warrants:
  - (a) That all applicable provisions of Executive Order No. 11,246, dated September 24, 1965, the Rules and Regulations promulgated thereunder by the Office of Federal Contract Compliance of the United States Department of Labor, and all applicable requirements of the Equal Employment Opportunities subchapter of the Civil Rights Act of 1964, have been fully met and observed in respect of the manufacture of the materials and equipment or the performance of services covered by this order;

FLINT CREEK POWER PLANT

SOUTHWESTERN ELECTRIC POWER COMPANY

GENERAL CONDITIONS

1. GENERAL

These specifications cover the Plant Area clearing and grubbing, plant site and coal yard grading, ash pit dike construction and related work, railroad bed construction, excavation and embankment for generating plant area, and other work as per attached drawing(s) and the following specifications. We have attempted to list all major requirements of construction, and any requirements not specifically covered by these specifications and/or drawings, but essential to the accomplishment of this project as proposed herein will be considered a part of the contract price to satisfactorily complete this job.

2. DRAWINGS

Drawings will show the scope of the work. All such drawings shall be considered as a part of these specifications.

3. INTERPRETATION OF DRAWINGS AND BIDDING DOCUMENTS

If any Contractor contemplating submission of a bid for the proposed work is doubtful as to the true meaning of any part of the specifications, or other contract documents, or finds discrepancies in or omissions from the drawings or specifications, he shall submit to Southwestern Electric Power Company, hereinafter referred to as "Owner", a written request for interpretation or correction thereof. Interpretation or correction of the contract documents will be mailed or delivered to each Contractor receiving a set of documents. The Owner will not be responsible for any other explanations or interpretation of the proposed documents.

4. CHANGES AND ALTERATIONS

The Owner, through its inspector or accredited representative, will have the right to make such changes and alterations in the quantities of work as may be considered necessary or desirable, and such changes shall not be considered as a waiver of any condition of the contract, nor shall they invalidate any of the provision thereof. The Contractor shall perform the work as increased or decreased, and no allowances will be made for anticipated profits. Altered quantities will be paid for at the contract unit price.

beyond the control of the party affected, including, but not limited to, acts of governmental authority, acts of God, strikes or other concerned acts of workmen, unavailability or substitution or diversion of labor or materials and operating equipment, fires, floods, explosions, riots, war, rebellion, and sabotage, but the foregoing shall not be considered a waiver of either party's obligations under this agreement.

21. PROTECTION OF ADJOINING PROPERTY

The said Contractor shall take proper means to protect the adjacent or adjoining property or properties in any way encountered, or which may be injured or seriously affected by any process of construction, to be undertaken under this agreement, from all damage or injury by reason of said process of construction; and he shall be liable for any and all claims for such damage on account of his failure to fully protect all adjoining property. The Contractor shall be responsible for the protection from damage by fire, falling trees or any other cause resulting from the contract work, of the property, crops, timber, grass, livestock, fences, gaps, gates, cattleguards, buildings, or any other assets of adjoining landowners. The Contractor shall be responsible for the repair of such damaged property and shall make repairs without delay.

22. HEADINGS OF ARTICLES

The headings of articles, sections, paragraphs, and other parts of the contract are for convenience only and do not define, limit or construe the contents thereof.

23. PAYMENT

- A. Purchaser agrees to pay the Contractor monthly as the work is completed but the total of such payments on account shall at no time exceed ninety percent (90%) of the mutually agreed upon value of the work completed.
- B. Ten percent (10%) upon completion of work and accept.
- C. Owner shall furnish engineering required to determine quantities for payment.

24. PROTECTION OF BENCHMARKS

Benchmarks, stakes, marks, etc., shall be carefully preserved by the Contractor, and in case of careless destruction or removal by him or his employees, such benchmarks, stakes, marks, etc., shall be replaced by the Owner at the Contractor's expense.

25. ENGINEER

Whenever the word Engineer is used in this contract, it shall be understood as referring to the Owner's authorized engineer or supervisor unless specifically noted otherwise.



JOB SPECIFICATIONS  
FOR  
ASH PIT DIKES  
FLINT CREEK POWER PLANT

GENERAL DESCRIPTION

The coal fired plant will require an area for storage of ash. A forty-one (41) acre pit will be utilized as a settling area for ash. A smaller pit will be used as a secondary settling area. The effluent of this secondary will then flow into the main lake.

This specification will cover construction of the containment dikes, clearing the primary and secondary settling basins, building the interconnecting canal and excavating within the secondary basin. Cross sections of the dikes and interconnecting canal are shown on FCX-3. Areas to be excavated or filled are shown on FCX-4.

This specification will also cover the placement of temporary culverts under the dikes and construction of a spillway connecting the secondary ash settling basin to the lake as shown on Drawing FCX-4.

**BRADLEY & BUNNEY  
ENGINEERS  
CHICAGO**

**JOB SPECIFICATION  
FLINT CREEK - UNIT 1  
SOUTHWESTERN ELECTRIC POWER COMPANY**

ASH PIT DIKES

SCOPE OF WORK

Construction of ash pond DIKES, including clearing, grubbing, placing compacted fill, structures on dike pipes through dike. Wier box complete by others

**1-1 WORK FURNISHED AND INSTALLED OR PERFORMED:** Contractor shall furnish, fabricate, deliver and unload materials and equipment for, shall store, protect and remove materials and equipment from storage for, and shall install, construct, erect or perform and finish the following WORK:

- a. Earthwork, including clearing and grubbing, excavation, backfilling, filling and soil compaction control.
- b. Construction of earth dikes along the sides and within the ASH Storage Area.
- c. Miscellaneous Construction including concrete work, metalwork, carpentry work, and galvanized corrugated metal pipes.
- d. Grass work, including soil preparation, seeding, fertilizing and maintenance.
- e. Bedding courses and riprap as shown on the drawing.

**1-2 RESPONSIBILITY FOR RESTRICTION OF NATURAL DRAINAGE DURING FILL PLACEMENT:**

Contractor shall not place any fill for dikes, etc., across routes of natural drainage until provisions are made to drain surface runoff into drainage ditches forming a part of the WORK.

No surface runoff shall be ponded or restricted to a greater degree than would have occurred naturally either before the beginning of construction or after completion of the WORK, unless approved by Purchaser's representative.

Should ponding or restriction of surface runoff result in water being backed up onto property not owned by Purchaser or onto Purchaser's property where work by other contractors is either under way or completed or where materials or equipment are being stored, all damages resulting therefrom shall be responsibility of Contractor.

Temporary Slopes: Temporary construction slopes in excavation or in fill used for temporary drainage channels shall not be steeper than 3 horizontal to 1 vertical, except as indicated on the drawings or as approved.

**SARGENT & LINDY  
ENGINEERS  
CHICAGO**

ASH PIT DIKES

SOUTHWESTERN ELECTRIC POWER COMPANY

DIVISION 2 - TECHNICAL REQUIREMENTS

**SECTION 2-1: EARTHWORK**

**2-1.1 SECTION SCOPE**

2-1.1.1 This section of the Specification includes requirements for the following, as indicated on the drawings, as hereinafter specified (under the Article numbers indicated), or as required to properly complete the WORK:

- 2-1.2 Services of Testing Laboratory
- 2-1.3 Soil Data and Topography
- 2-1.4 Removal of Sod and Topsoil
- 2-1.5 Excavation
- 2-1.6 Compacted Fill
- 2-1.7 Equipment
- 2-1.8 Fill Placement
- 2-1.9 Backfill
- 2-1.10 Excavation & Fill for Corrugated Metal Drainage Piping
- 2-1.11 Drainage Ditches
- 2-1.12 Bedding Course for Riprap
- 2-1.13 Riprap
- 2-1.14 Grading
- 2-1.15 Seeding

**2-1.2 SERVICES OF TESTING LABORATORY**

Will be furnished by Purchaser for use in connection with controlled compacted fill, as specified in Article 6.2 of Form 1714.

**2-1.3 SOIL DATA AND TOPOGRAPHY**

As specified in Article 2 of Form 1714. Drawings are included, and borings will be available for inspection at SWEPCo or Stewart, White & Associates, Inc.

**2-1.4 REMOVAL OF SOD AND TOPSOIL**

As specified in Article 4.6 of Form 1714. Stockpile topsoil on site, where and as requested by Purchaser's representative, for later reuse. Dispose of sod on site as requested by Purchaser's representative.

**2-1.5 EXCAVATION**

2-1.5.1 As specified in Article 5 of Form 1714. Dispose of all excavated materials on site, either as fill material or in stockpile area, as requested by Purchaser's representative. The Contractor's unit price for excavation shall be based on a free haul distance of 2000 feet. In the event that the Contractor is required to haul dirt in excess of the 2000 foot free haul distance he shall be paid at the unit price for overhaul per yard - quarter. Item 140 (Overhaul) of the 1972 Texas Highway Standard Specification is hereby referenced as the governing specification. The 2000 foot free haul distance substituted for the 600 foot free haul distance specification in Item 140. Approval and authority in writing from the Engineer must be obtained before payment will be made for overhaul.

2-1.5.2 Area of stockpile shall be cleaned of vegetation and disposed of as specified in Article 4.5 of Form 1714.

2-1.5.3 Dewatering: As specified in Article 5.3 of Form 1714 and as indicated on the design drawings. During course of the WORK, Contractor shall maintain sufficient slope in excavation and on fill area to permit drainage of surface water and maintaining a dry working condition.

2-1.6 COMPACTED FILL

2-1.6.1 Conform to the applicable requirements of Article 6 of Form 1714 and requirements hereinafter specified.

2-1.6.2 Class and Type: One of the following as indicated on the drawings:

- a. Class 1, Regular Compacted Fill, Type RCF1, Granular Material.
- b. Class 1, Regular Compacted Fill, Type RCF2, Cohesive Material.
- c. Class 2, Controlled Compacted Fill, Type CCF1, Granular Material.
- d. Class 2, Controlled Compacted Fill, Type CCF2, Cohesive Material.

2-1.6.3 Material: Shall be impervious fill material obtained from excavation and borrow areas on site as indicated on the drawings, or from other approved stockpiles or borrow areas off site. All sources of dike fill shall be designated and approved by the Purchaser's representative. The fill material shall not contain any cobbles or broken rock larger than nine (9) inches maximum dimension at time of placement and compaction.

2-1.6.4 Compaction Densities: Dike fill shall be loosely placed in layers not exceeding ten (10) inches. Each layer of fill shall be thoroughly compacted by means of a sheepfoot roller or pneumatic tired rollers of adequate capacity and through sufficient coverages to obtain not less than 90 percent of the maximum Modified Proctor density in accordance with ASTM Test D1557, latest edition.

2-1.6.5 Disposal of Organic Materials: Vegetation, organic material, and other foreign materials removed in preparation of subgrade, as specified in Articles 6.3.3 and 6.4.3.2 of Form 1714, shall be disposed of on the site as requested by Purchaser's representative.

2-1.6.6 Preparation of Subgrade: Prior to placement of fill material and after stripping, the subgrade shall be compacted (proofrolled) through sufficient passes of an approved sheepfoot roller capable of densifying the present surface to not less than 90 percent of the maximum Modified Proctor density in accordance with ASTM Test D1557.

**SARGENT & LUNDY  
ENGINEERS  
CHICAGO**

**2-1.7 EQUIPMENT**

**2-1.7.1 Compaction Equipment:** Equipment to be used for constructing fill may consist of any type normally considered suitable to construct embankments for dams or highways. Main compaction equipment, including heavy pneumatic tired rollers, sheepfoot rollers, vibratory compactors, shall be subject to approval of Purchaser's representative.

a. In addition to the foregoing equipment, Contractor shall have the following equipment available at the WORK:

a.1 Power tampers to be used for compaction of material in areas where it is impractical to use a roller or tractor.

a.2 A plain cylindrical roller, weighing not less than 1,000 pounds per lineal foot for rolling the surface of fill smooth for drainage in case of heavy precipitation.

a.3 Discs, harrows, and motor graders for drying and maintaining fill.

**2-1.8 FILL PLACEMENT**

**2-1.8.1** As specified in Paragraph 6.4.5 of Form 1714, and as follows:

a. Distribution and gradation of materials throughout rolled fill shall be such that fill will be free from lenses, pockets, streaks or layers of material differing materially in texture or gradation from surrounding material. Combined excavation and placing operations shall be such that materials when compacted in the fill will be blended sufficiently to secure the best practicable degree of compaction, and stability. Travel on the fill shall be satisfactorily controlled to prevent tracking or cutting fill.

b. Successive loads of material shall be dumped so as to produce the best practicable distribution of material, and for this purpose locations in earth fill where individual loads shall be deposited may be designated. If the surface of any layer of material to be placed thereon has formed a hard over-compacted crust from traffic, it shall be moistened or both moistened and scarified as required before the succeeding layer of material is placed.

c. When rain is expected, and at the end of each working day, fill shall be rolled with a plain cylindrical roller to form a smooth surface with sufficient slope to cause rapid runoff of rainwater. Before resuming placement, this surface shall be scarified and moistened, as required. If Purchaser's representative determines that the rolled surface of any layer of earth

fill in place is too wet for proper compaction of fill thereon, it shall be removed, allowed to dry, or shall be worked with a harrow, scarifier or other suitable equipment, to reduce water content to the required amount, and then shall be recompact. Do not place the next succeeding layer of fill until approval to proceed is given by Purchaser's representative and the Consulting Engineers.

- d. All openings through embankments required for construction and temporary drainage purposes shall be subject to approval. Approach or construction ramps for dikes and embankments shall be removed and those on the outside face shall be removed and/or trimmed, as requested.

2-1.9 BACKFILL

2-1.9.1 As specified in Article 7 of Form 1714.

2-1.9.2 Material shall be same as indicated in Article 2-1.6.3 for Compacted Fill.

2-1.10 EXCAVATION AND FILL FOR CORRUGATED METAL DRAIN PIPING

As specified in Article 9 of Form 1746.

2-1.11 DRAINAGE DITCHES

Cut and/or fill drainage ditches (if required) to cross sections and profiles indicated on the drawings. All surfaces shall be well compacted.

2-1.13 RIPRAP

2-1.13.1 Material:

**MARGENT & LUNDY**  
**ENGINEERS**  
CHICAGO

- a. Riprap shall consist of quarried stone, or other stone, free from structural defects and of approved quality. Stone containing shale, unsound sandstone or any other material which will readily disintegrate under handling and placing or weathering, shall not be used. Any stone which is free from incipient fractures and seams and has given evidence of ability to withstand weathering after long exposure to the elements shall be considered suitable for this purpose. Upon presentation of satisfactory evidence of ability to withstand weathering, such stone may be used without laboratory testing.
- b. In case newly quarried stone or stone of questionable weathering quality is proposed, it shall be subjected to the sodium sulphate soundness test and shall show a loss, after cycles, of not more than 25 percent. Materials failing this test may be approved if, when subjected to fifty cycles of freezing and thawing, it has a loss not greater than 25 percent. Soundness method AASHTO T104 (ASTM C88), "Method of Test for Soundness of Aggregate by Use of Sodium Sulfate or Magnesium Sulfate" or T103, "Method of Test for Soundness of Aggregates by Freezing and Thawing" shall be used.
- c. The moist unit weight of riprap shall not be less than 164 pounds per cubic foot.

**2-1.13.2 Size and Gradation**

- a. Riprap shall be reasonably well graded and quarried stone shall have a gradation conforming to the following weight limits:
  - a.1 Maximum size.....450 lbs.
  - a.2 At least 25 percent greater than.....200 lbs.
  - a.3 45 percent - 75 percent from - to.....80-120 lbs.
  - a.4 Not more than 25 percent less than.....50 lbs.
  - a.5 Sand and rock dust not more than.....5 percent
- b. The shortest dimension of any stone shall be not less than 1/3 of the longest dimension for at least 60 percent of the riprap. For the balance, the shortest dimension shall be not less than 1/5 of the longest dimension.
- c. Alternate sizes and gradations will be considered for the WORK if they will achieve the desired performance at less cost. If an alternate is proposed, size and gradation of alternate shall be stated in the Bid Proposal, together with the price saving.

2-1.13.3 Placing:

- a. Riprap shall be placed by dragline, clamshell or similar equipment which shall be operated so as to place each load of material in approximately its final position without further reworking, and without excessive height of drop.
- b. Placement operations, including handling, stockpiling and transporting, shall be accomplished in such manner so as to produce a reasonably well graded mass of rock with minimum percentage of voids, free from objectionable pockets of small stones and clusters of large stones and having a reasonably regular finished surface.
- c. Riprap shall be placed on the face of the dikes to the lines and grades and to the minimum thickness indicated on the drawings. The riprap shall be placed to this full minimum thickness in one operation. Thickness shall not be less than the minimum at any point. Hand placing to a limited extent may be required, but only to the extent necessary to secure results specified foregoing.
- d. In no case shall a bulldozer be used in shaping the riprap slopes.

2-1.14 GRADING

As specified in Article 8 of Form 1714, and as indicated on the drawings.

2-1.15 SEEDING

2-1.15.1 All slopes and surfaces, as indicated on the drawings, shall be seeded as hereinafter specified.

2-1.15.2 Topsoil:

- a. Material: Approved topsoil from topsoil previously excavated and stockpiled on the site or approved topsoil from sources off the property or both.
- b. Placing:
  - b.1 Spread topsoil evenly to a depth which, after settlement and compaction, shall be 4 inches. Do not spread when ground or topsoil is excessively wet or otherwise in any condition detrimental to the work; if existing surface has become hardened or crusted, rake or otherwise break up to provide bond with layer of topsoil.
  - b.2 After spreading has been completed, rake up and remove large clods, stones larger than 2 inches in any dimension, roots, stumps, and other litter or deleterious material.



- b.3 Completed finish grading shall provide a smooth grade, true to indicated elevations, cross sections and profiles, properly drained and free from pockets or high spots, and as approved for subsequent fertilizing and seeding operations as hereinafter specified.

2-1.15.3 Fertilizing:

- a. Material: Ready-mixed material having an analysis of 16-8-8 nitrogen, available phosphoric acid and water soluble potash. Deliver to job in sealed containers with weight, analysis, and name of manufacturer clearly indicated on each container.
- b. Storage: Store in such a manner as will not impair fertilizer's effectiveness.
- c. Coverage: 300 lbs. per acre.

2-1.15.4 Seeding:

- a. Seeding Time: Do fertilizing and seeding as soon as possible after completion of finish topsoil work. However, do no fertilizing or seeding during windy weather or when ground is wet or in an otherwise untillable condition.
- b. Seed:
- b1. Seed shall be un-hulled Bermuda and Rye grass with purity and germination of 95 and 90, respectively.
- b2. Coverage: Bermuda 5 lbs. per 1000 SY - Rye grass 21 lbs. per 1000
- b3. All seed shall comply with all applicable laws and regulations of the State of Arkansas and of U.S. Department of Agriculture.
- c. Have seed delivered to job in sealed containers.
- d. Furnish to Purchaser duplicate signed copies of statement by seed vendor that each lot of seed has been tested by a recognized laboratory for seed testing within six months of date of delivery, and complies with all requirements for the specified seed.
- e. Protection: Immediately after seeding, cover seeded areas with two (2) tons per acre of straw mulch and anchor this by spraying with cutback asphalt (RC-3) at the rate of .10 gallon per sq. yd.
- f. Sowing and Maintaining, Etc.: Methods of preparation of seed beds, fertilizing, seeding, sprinkling, maintaining, repair, and reseeding as required will be at option of Contractor. Work shall not be considered complete until after a uniform and dense stand of healthy grass has been produced in accordance with these specifications, free from bare spots and gullies formed by erosion, and when accepted in writing by Purchaser.

**SARGENT & LUNDY**  
**ENGINEERS**  
**CHICAGO**

ASH PIT DIKES

SOUTHWESTERN ELECTRIC POWER COMPANY  
FLINT CREEK POWER PLANT - UNIT #1  
DIVISION 2 - TECHNICAL REQUIREMENTS

SECTION 2-2: CLEARING AND GRUBBING

2-2.1 SECTION SCOPE

2-2.1.1 This Section of the Specification includes requirements for the following, as indicated on the drawings, as hereinafter specified (under the Article numbers indicated, or as required to properly complete the WORK

2-2.1.2 Requirements of Division 1, General Requirements, also apply to the WORK under this Section 2-2.

2-2.2 TREE REMOVAL AND CLEARING

2-2.2.1 Conform to applicable requirements of Article 4 of Form 1714, and to requirements hereinafter specified.

2-2.2.2 Tree Removal:

a. Clear and grub all trees in the following areas.

1. Dike borrow areas.

2. Within the toes (the entire base) of lake and ash pond dikes.

b. All other trees within the lake and ash pond dikes shall be sheared at ground level.

c. Remove and dispose of off the site all partially buried logs, down timber, snags, brush, hedges, bushes and all other vegetation or organic material, all rubbish, debris and other foreign or objectionable material above ground surface.

d. Remove all floating debris in swampy areas and dispose of off site. Cut all trees in swampy areas as directed by Owner's Engineer.

2-2.2.3 CLEARING

a. Contractor shall have full property rights to all timber cut by him, and may sell, off the site only, all merchantable timber which he cuts. Merchantable timber may be processed either on the site or off the site, as agreed to with Purchaser, but shall all be removed from the site before completion of the WORK.

2-2.2.4 ESTIMATED QUANTITY: 50 acres clearing  
12 acres clearing and grubbing

2-2.2.5 BASIS FOR PAYMENT: Price per acre clearing  
Price per acre clearing and grubbing

STANDARD SPECIFICATION FOR  
EARTHWORK

(Form 1714)

1. GENERAL

- 1.1 Earthwork shall conform to the requirements of this Standard Specification, the Job Specification, and the design drawings. In the event of variance between this Standard Specification and the Job Specification or design drawings, the Job Specification and the design drawings shall take precedence.
- 1.2 Where the terms "as indicated" or "indicated" are used in this Standard Specification, they shall mean "as shown, noted, called for or specified".
- 1.3 All references to the following publications are to the latest issue of each, together with the latest additions and/or amendments thereto, as of the date of Contract, unless otherwise indicated; references to the sponsoring agencies will be made in accordance with the abbreviations indicated:
- 1.3.1 ASTM ..... American Society for Testing and Materials  
Standard Specifications.
- 1.3.2 ASA ..... American Standards Association Standard  
Specifications.
- 1.3.3 AASHTO ..... American Association of State Highway  
Officials Standard Specifications.

2. SOIL DATA AND TOPOGRAPHY

- 2.1 Soil Data: Drawings show borings made at site, and logs given thereon indicate character of soil. This information furnished for Contractor's convenience; in using it Contractor assumes the risk, as Purchaser and the Consulting Engineers assume no responsibility for accuracy of information shown thereon. Contractor will be permitted to make his own soil investigations, but same shall be made at no cost to Purchaser.
- 2.2 Topography: Drawings indicate elevations, dimensions and/or cross sections, profiles and contour lines of existing ground. This information furnished for Contractor's convenience; in using it Contractor assumes the risk, as Purchaser and the Consulting Engineers assume no responsibility for accuracy of information shown thereon. Contractor will be permitted to make his own investigation of topography during bid period, but same shall be made at no cost to Purchaser.

3. LINES AND GRADES

- 3.1 Contractor shall lay out lines and grades from existing base lines and bench marks on property and be fully responsible for correctness of such lines and grades and for proper execution of WORK to such lines and grades.

- 3.2 Purchaser reserves right to verify correctness of lines and grades during progress of WORK. Such verification by Purchaser will not relieve Contractor of responsibility as specified foregoing.
- 3.3 Contractor shall notify Consulting Engineers of any differences in location of existing work from that indicated, wherever such differences may affect new work.
- 3.4 Contractor shall preserve and maintain all bench marks and reference points established by Purchaser. Should Contractor, during prosecution of WORK, destroy or remove any bench marks and/or reference points established by Purchaser, the cost to Purchaser of re-establishing these bench marks and/or reference points will be charged to Contractor.
4. CLEARING
- 4.1 Prior to performing excavation or fill work, areas in which such work is to be done shall be cleared, grubbed and the top soil and sod removed. No clearing, grubbing or removal of top soil and sod shall be done outside designated areas without specific approval.
- 4.2 If extensive clearing, grubbing and removal of top soil and sod is required, the Job Specification or drawings will specifically so indicate. If such work is incidental, then it will not be specifically indicated and shall be performed prior to, but as part of, excavation work.
- 4.3 Clearing:
- 4.3.1 Clearing is defined as removal and disposal of all trees, down timber, snags, brush, hedges, bushes and all other vegetation or organic materials, and also all rubbish, debris or other foreign or objectionable materials above ground surface, except removal of sod and top soil.
- 4.3.2 Removal of structures, such as buildings, roadways, fences, etc., is classified as demolition and not as clearing, and will be indicated in the Job Specification (under Demolition Work) or on drawings.
- 4.3.3 Trees shall be filled in such manner as not to damage other trees or other vegetation which are to remain in place nor damage existing structures and facilities nor constitute a hazard to traffic or life.
- 4.4 Grubbing: Grubbing is defined as removal and disposal of all stumps, large roots, buried logs and all other objectionable material from below ground surface. Explosives may be used only if specifically approved and their use shall conform to all applicable laws and safety regulations.
- 4.5 Disposal:
- 4.5.1 All materials from clearing and grubbing operations shall be Contractor's property and shall be promptly disposed of off the site unless otherwise indicated in the Job Specification or on drawings; accumulation of such materials on premises not permitted.
- 4.5.2 Burning of Debris on Premises: If burning of debris on premises is permitted by the Job Specification, drawings or Purchaser, conform to following requirements:
- 4.5.2.1 Burn debris only in areas specifically designated by Purchaser.

SARGENT & LINDY  
ENGINEERS  
CHICAGO

4.5.2.2 Prior to burning any material, secure approval and permits from, and comply with all regulations of all authorities and all public bodies having jurisdiction in area of WORK.

4.5.2.3 Neatly pile all combustible material and burn when in suitable condition. Do piling in such manner and in such locations as to cause least fire risk.

4.5.2.4 Burn material thoroughly and completely so that materials are reduced to ashes, with no charred pieces, such as charred logs, remaining. Ashes and charcoal residue need not be removed. Combustible materials difficult to burn, such as tree stumps and root clumps, may be buried below grade, with not less than 1'-0" of cover over them and level with surrounding grade, if grubbing is not required for the WORK; if grubbing is required, then all such unburnable materials shall be disposed of off the premises.

4.5.2.5 Fire Protection: Provide fire fighting facilities, satisfactory to authorities having jurisdiction and to Purchaser and maintain such facilities in first class operating condition during course of burning operations.

4.6 Removal of Top Soil and Sod:

4.6.1 Top soil and sod shall be removed as part of excavation work, unless the Job Specification or drawings indicate that top soil and/or sod shall be removed and stored for reuse by Contractor or by others.

4.6.2 If top soil is indicated to be removed for reuse, it shall be carefully stripped off, stored in separate stockpiles and kept clean and free of all foreign material. Sod and other vegetation shall be removed from the top soil before it is stockpiled.

4.6.3 If sod is indicated to be removed for reuse, it shall be carefully removed, rolled up, and stored in a suitable and well protected manner, as approved.

4.6.4 If top soil and/or sod is indicated to be reused by Contractor, any and all excess stockpiles remaining on completion of WORK shall be removed and disposed of off the premises unless otherwise requested.

**5. EXCAVATION**

5.1 Excavation is defined to include all incidental clearing, all excavation and disposal of excavated materials, all protection, sheeting, shoring, bracing and cofferdams, all dewatering, and preparation of bearing areas as required to properly install and complete the WORK, regardless of portions of WORK for which required, and regardless of nature of materials encountered in excavating. Dredging shall be performed only if specified in the Job Specification or on the drawings.

5.2 Classification: Excavation shall be classified as earth or rock excavation, as follows:

5.2.1 Earth excavation is all material not classified as rock excavation.

5.2.2 Rock Excavation:

5.2.2.1 Rock excavation is defined as any material that requires the continuous use of drilling and blasting, or drilling, channeling, etc., and shall include granite, trap, quartzite, chert, limestone, hard sandstone, hard shale or slate or other similarly hard materials, as

- well as rocks and boulders measuring 1/2 cubic yard or more.
- 5.2.2.2 The Job Specification or drawings will indicate whether blasting is permitted. Blasting, if permitted, shall conform to requirements of 5.11, following.
- 5.3 Dewatering: Contractor shall provide and operate all dewatering equipment required for areas excavated by Contractor, and be responsible for maintain a dry site satisfactory to Purchaser and Consulting Engineers.
- 5.4 Protection and Support:
- 5.4.1 Contractor shall provide all protection and support as required to properly install the WORK, as required for protection and support, of the WORK and of adjacent structures and improvements, and as required for safety of traffic and life.
- 5.4.2 Protection and support shall include temporary sheeting, bracing, shoring and cofferdams, and also, where indicated, permanent sheeting, bracing and shoring. All temporary sheeting, bracing, shoring and cofferdams shall be as approved, and all such temporary work shall be removed by Contractor when its use is no longer required, unless otherwise requested or approved.
- 5.4.3 Banks at excavations shall be protected and supported, where necessary or where requested, so that the banks and bottoms will be maintained and adjacent structures or other construction will be protected from damage caused by any earth or rock movement.
- 5.4.4 Protection and support shall be arranged for minimum interference with pipe laying, electrical ductwork installation and similar work.
- 5.4.5 Temporary Cofferdams: Contractor shall design temporary cofferdams required by him to perform his work and shall submit drawings thereof for approval. These drawings shall show all data on which the design is based. No such work shall be installed until such approval is received, and the work shall be done only in accordance with these approved drawings.
- 5.5 Earth excavations shall be of sufficient size to allow for placing of formwork for concrete, for inspection of formwork and surfaces of completed concrete, and for dampproofing, waterproofing, pipework, electrical ductwork, etc. Rock excavations shall be to neat lines unless otherwise indicated; where overbreak of rock occurs behind a vertical face of concrete placed against rock, overbreak shall be filled with the same concrete as required for the vertical face, and no payment will be made for concrete fill.
- 5.6 Excavations shall be carried to elevations indicated on drawings, and as follows:
- 5.6.1 Earth Excavation: Foundation excavations carried below the indicated level shall be filled with the same concrete as required for the foundation; other earth excavations carried below the indicated level shall be brought up to the proper level with compacted fill, sand, crushed stone, gravel or concrete, as determined most suitable by the Consulting Engineers.

**SARGENT & LUNDY  
ENGINEERS  
CHICAGO**

- 5.6.2 Rock Excavation: When designated or approved elevations have been reached, rock surfaces shall be leveled off and all loose rock removed. Where overbreak of rock results in dropping elevations of rock surfaces below designated or approved elevations, overbreak shall be filled with the same concrete as required for the foundations.
- 5.6.3 No payment will be made for any of the foregoing specified fill required to remedy over-excavation in earth or overbreak in rock.
- 5.7 Hand excavation shall be used, if requested, for trenching or other excavation adjacent to structures or equipment where use of mechanical excavating equipment is not considered advisable by Purchaser or the Consulting Engineers.
- 5.8 Bearing Areas:
- 5.8.1 Bearing areas for all foundations shall be inspected and approved by Purchaser or the Consulting Engineers before any concrete is placed. If bearing areas are not suitable, as determined by the Consulting Engineers, Contractor may be requested to carry the excavations deeper to more suitable bearing material; such additional excavation will be paid for on the unit price basis set forth for the WORK. Contractor may also be requested by the Consulting Engineers to make auger borings or other tests at bearing areas to determine thickness of bearing stratum; these tests will be paid for on a unit price or cost plus basis, whichever is set forth for this item.
- 5.8.2 All foundations shall be placed on undisturbed soil unless otherwise indicated or approved.
- 5.8.3 Before placing any concrete for beams or slabs on fill, the soil shall be well tamped.
- 5.8.4 Before placing any concrete on soil that will absorb water, the surface of the soil shall be thoroughly wet with clean water immediately before the concrete is placed.
- 5.9 Excavation for Pipework and Electrical Ductwork:
- 5.9.1 Make excavation for this work true to grade, profile and alignment, and so as to provide full, even and continuous bedding. For pipework, normally excavate trenches to match curve of pipe; however, flat beds may be used if as economical as curved beds, or shall be used if indicated.
- 5.9.2 Where granular bedding under pipework or ductwork is indicated in the Job Specification or on drawings, excavate the additional amount required to place the indicated depth of bedding material.
- 5.10 Disposal of Excavated Materials:
- 5.10.1 Deposit and spread, or stockpile, excavation materials suitable (in opinion of Consulting Engineers) for fill or backfill, in quantities required and approved, on premises where requested.
- 5.10.2 For excavated materials not suitable for fill or backfill, the Job Specification or drawings will indicate whether such material is to be disposed of on or off premises, and disposal shall accordingly be as follows:
- 5.10.2.1 For such material to be disposed of on premises, deposit or spread on premises where approved or requested.

- 5.10.2.2 For such material to be disposed of off premises, promptly remove this material as excavated; stockpiling of such material will not be permitted.
- 5.10.3 After completion of fill and backfill work, or when approved or requested, dispose of any and all excess stockpiles or excess excavated materials either on or off the premises as specified in 5.10.2 foregoing.
- 5.11 Requirements for Blasting: If use of blasting is approved by Purchaser or Consulting Engineers, blasting shall conform to following requirements:
- 5.11.1 Blasting shall be performed only when proper precautions are taken for protection of persons, the work, private property, etc. Caps or other exploders or fuses shall in no case be stored or transported in same place in which dynamite or other explosives are transported. Location of storage magazines, methods of transportation and, in general, precautions taken to prevent accidents shall, at all times, be subject to approval of Purchaser or Consulting Engineers, but Contractor shall at all times be liable for any injuries to persons or property caused by explosives.
- 5.11.2 Every possible precaution shall be taken in blasting operations to preserve rock outside lines of excavation in soundest possible condition. Blasting shall be done only to lines and grades indicated on drawings or as approved by Consulting Engineers.
- 5.11.3 Explosives shall be of such quantity and power and shall be used in such locations as will not tend to open seals, or to crack or damage rock outside prescribed limits of excavation. If needed, firing of blast shall be controlled by use of delayed explosives. Whenever, in the opinion of Consulting Engineers, continuation of blasting may injure rock on which or against which concrete is to be placed, use of explosives shall be discontinued and excavation shall be completed by wedging, boring, channeling or other suitable means.
- 5.11.4 Contractor shall submit plans and methods of operation for rock excavation work before work is started. Approval of method of blasting or of strength and amount of explosives used will not relieve Contractor of responsibility for blasting operations.
- 5.11.5 For blasting, Contractor shall employ a supervisor thoroughly experienced in this type of work and shall at all times maintain rigid inspection to see that intent of these requirements are fully complied with.
- 5.11.6 Contractor shall maintain a complete and detailed record of blasting operations, in a form approved by Purchaser, and shall submit copies of such records to Purchaser as requested.



**SARGENT & LINDY**  
**ENGINEERS**  
CHICAGO

5.12 Dredging:

- 5.12.1 Before submittal of bid, Contractor shall obtain a sweeping map from The U. S. Army Corps of Engineers, and shall also determine from them the full extent of their requirements as it will affect the WORK.
- 5.12.2 Contractor shall furnish, establish and maintain in good order all range marks, stakes, gauges and buoys required for proper execution of this work, and furnish, on request, the use of such boats, boatmen, laborers and materials forming a part of the ordinary and usual equipment and crew used for this work as may be necessary for Purchaser, Consulting Engineers and Corps of Engineers to inspect work.
- 5.12.3 Contractor shall provide sounding and sweeping equipment and labor to sound and sweep dredged areas to establish that indicated grade, profile and alignment are met.
- 5.12.4 As soon as possible after completion of dredging work, Contractor shall thoroughly examine dredged area by sounding and sweeping to determine that completed work meets all requirements indicated on drawings and all requirements specified by Corps of Engineers. Arrange with Purchaser for representatives of Purchaser, Consulting Engineers and Corps of Engineers to be present when sounding and sweeping is performed. However, the presence of these representatives shall in no way relieve Contractor of responsibility for accuracy and proper completion of the work.
- 5.12.5 Any shoals, lumps or other lack of Contract dimensions disclosed by the foregoing examination shall be remedied by Contractor, and shall again be sounded, and swept if required, until the entire dredged area is satisfactory in every respect to Purchaser, Consulting Engineers and Corps of Engineers.
- 5.12.6 Contractor shall maintain a complete record of soundings, in a form approved by Consulting Engineers, and shall submit copies of such records to Consulting Engineers as requested.

6. FILL

- 6.1 Fill includes the following two classes, with two types under each class; the use of each shall be as indicated in the Job Specification or on the drawings:
- 6.1.1 Class 1: Regular compacted fill, Types RCF1 and RCF2.
- 6.1.2 Class 2: Controlled compacted fill, Types CCF1 and CCF2.
- 6.2 Services of Testing Laboratory: Where controlled compacted fill is specified, Purchaser will furnish services of a Testing Laboratory to determine suitability of fill material, to set optimum moisture contents, and to perform field tests to check on compliance with moisture and density requirements. Contractor shall furnish Testing Laboratory with all required quantities of fill material, from the same source as will be used for the WORK, as required for test purposes.

- 6.3 Class 1, Regular Compacted Fill:
- 6.3.1 The two types are based on the materials specified for use as fill, as follows:
- 6.3.1.1 Type RCF1: Granular material (sand, crushed stone, gravel, etc.)
- 6.3.1.2 Type RCF2: Cohesive material (clay, sandy loam, silty loam, etc.)
- 6.3.2 Material: The Job Specification or drawings will indicate the source of materials to be used, such as material previously excavated at the site, or from borrow pits, or from off site sources, etc. All material used shall be as approved by Purchaser and/or the Consulting Engineers.
- 6.3.3 Preparation of Subgrade: Prior to placing regular compacted fill, strip areas to be covered of all vegetation or other organic material or other foreign or deleterious material.
- 6.3.4 Compaction Densities: Build up fill to grade elevations indicated or required, with suitable moisture control and compaction throughout placing, as specified in 6.3.5 following, to produce a completed fill capable of supporting trucks and other heavy construction equipment.
- 6.3.5 Placing of Fill: Place as follows, unless otherwise approved or requested:
- 6.3.5.1 Place fill, with suitable moisture content, in uniform horizontal layers not over 9" deep before compaction.
- 6.3.5.2 For Type RCF1 granular fill, compact by successive high speed passage of heavy tractors (with treads covering 100% of area), or with other vibratory type equipment, as approved.
- 6.3.5.3 For Type RCF2 cohesive fill, compact by use of sheeps foot roller or with other ramming type equipment, as approved.
- 6.3.5.4 In places inaccessible to large equipment, obtain required compaction with mechanical vibrators for Type RCF1 granular fill, and with mechanical rammers for Type RCF2 cohesive fill.
- 6.4 Class 2, Controlled Compacted Fill:
- 6.4.1 The two types are based on the materials specified for use as fill, as follows:
- 6.4.1.1 Type CCF1: Granular material (sand, crushed stone, gravel, etc.)
- 6.4.1.2 Type CCF2: Cohesive material (clay, sandy loam, silty loam, etc.)
- 6.4.2 Material: Conform to same requirements specified in 6.3.2 for granular fill

6.4.3 Preparation of Subgrade:

6.4.3.1 Subgrade to receive controlled compacted fill shall be inspected by Purchaser or the Consulting Engineers to determine if it is suitable and has sufficient bearing capacity for the fill material and loads to be placed over it. If subgrade is not suitable, as determined by the Consulting Engineers, Contractor may be requested to perform additional excavation as specified in 5.8 for Bearing Area, with compensation as specified therein.

6.4.3.2 Prior to placing controlled compacted fill, strip areas to be covered of all vegetation, top soil and all organic material or other foreign or deleterious materials.

6.4.3.3 Thoroughly break and turn soil underlying the filled area to depth of 6 feet before deposition of fill material. Do breaking of ground no more than 200 feet in advance of placing fill.

6.4.4 Compaction Densities: Build up fill to grade elevations indicated or required, with suitable moisture control and compaction throughout placing, as specified in 6.4.5 following, to produce following densities:

6.4.4.1 Decidedly granular fill material: 90% of its maximum density.

6.4.4.2 All other fill material: 95% of its maximum density.

6.4.5 Placing of Fill: Place as follows, unless otherwise approved or requested:

6.4.5.1 Place fill, with optimum moisture content, in uniform horizontal layers not over 6" deep before compaction. Add water, or dry out fill, to maintain optimum moisture content throughout placing and compaction.

6.4.5.2 For Type CCF1 granular fill, compact by successive high speed passage of heavy tractors (with treads covering 100% of area), or with other vibratory type equipment, as approved.

6.4.5.3 For Type CCF2 cohesive fill, compact by use of sheeps foot roller or with other ramming type equipment, as approved.

6.4.5.4 In places inaccessible to large equipment, obtain required compaction with mechanical vibrators for Type CCF1 granular fill, and with mechanical rammers for Type CCF2 cohesive fill.

7. BACKFILL

7.1 Backfill includes general backfilling around all work excavated for by Contractor, and also all other backfill indicated on drawings as by Contractor.

7.2 Backfill shall be approved materials previously excavated at the site or materials obtained from approved borrow pits and shall be free of sod or other deleterious or foreign matter.

7.3 Backfill shall be built up to the grade elevations indicated or required, with suitable moisture control and compaction throughout placing, in the ~~same~~ manner as specified in 6.3 for Regular Compacted Fill, Types BCF1 and BCF2.

7.4 Backfill against foundation walls shall be placed only when directed.

- 7.5 Backfill Around Underground Piping: Place backfill around underground piping, drain lines, etc., only after piping, drain lines, etc., have been tested and/or inspected and approved. Use special care in backfilling to see that backfill is free of cinders or other materials which may be injurious, in opinion of Consulting Engineers, to such piping, drain lines, etc. Provide backfill free from rocks, hard lumps or clods larger than 3 inches. Do not use sod. Place backfill below top of piping, drain lines, etc., in alternate layers on each side of piping, drain lines, etc. Backfill around corrugated metal drainage pipe, corrugated structural plate pipe or welded steel plate pipe shall also conform to requirements specified in 7.6, following.
- 7.6 Backfill For Corrugated and Welded Steel Pipe:
- 7.6.1 Where flat beds for this piping is indicated in Job Specification or on drawings, provide flat granular bedding fill under pipe, with depth of bedding as indicated on drawings. Provide greater depth bedding fill if required by unsuitable soil conditions, as determined by the Consulting Engineers.
- 7.6.2 Granular Bedding: Use clean crushed stone or gravel, or other approved material, with 1-1/2" maximum size.
- 7.6.3 After pipe is in place on flat bed, provide controlled compacted granular fill under haunches. Use clean crushed stone, gravel or coarse sand, or other approved material, with 1-1/2" maximum size.
- 7.6.4 Also provide same controlled compacted granular fill up to center line of pipe.
- 7.6.5 Fill above center line of pipe and up to grade with select material, as approved, with controlled compaction.
- 7.6.6 Controlled compaction shall conform to requirements specified in 6.4 for Controlled Compacted Fill, Types CCF1 and CCF2. Services of Testing Laboratory will also be furnished for this work as specified in 6.2 foregoing.
- 7.6.7 Use extreme care in placing all compacted fill to maintain fill at approximately the same level (not to exceed one foot differential) on both sides of pipes throughout entire placing of compacted fill.
- 7.7 Backfill for Electrical Ductrums:
- 7.7.1 Requirement of Standard Specification STD-EP-103 that clay or loam backfill shall be used for ductrums shall not apply. Any approved previously excavated material may be used for backfill over ductrums that are cast in place, provided that maximum size of material shall not exceed two inches (2").
- 7.7.2 For precast concrete ductrums, provide a layer of clean, washed sand not less than 2" thick on SIDES AND TOP, with balance of backfill approved previously excavated material not exceeding 2" maximum size. Provide sand cushion for precast ductrums as specified in Job Specification under Concrete Work, or as indicated on drawings.

**SARGENT & LUNDY**  
**ENGINEERS**  
**CHICAGO**

- 7.8 Backfill in Roadways: Where existing roadways are cut to install new work, backfill such areas as quickly as possible after completion (including testing, if required) of new work. Bring backfill to within 10" of road surface ready for installation of new roadway by Contractor or by others as indicated in Job Specification or on drawings.
8. GRADING: Consists of rough grading and finish grading, as follows:
- 8.1 Rough Grading: Cut, fill, spread and level during course of WORK to elevations indicated.
- 8.2 Finish Grading: Fine grade and level to provide a smooth finish grade free of debris, foreign matter, objectionable stones, slods, lumps, pockets or high spots, properly drained and true to indicated elevations. Do finish grading only near completion of WORK or when requested.